

PARK BBQ

MODEL #NSS20 B6S

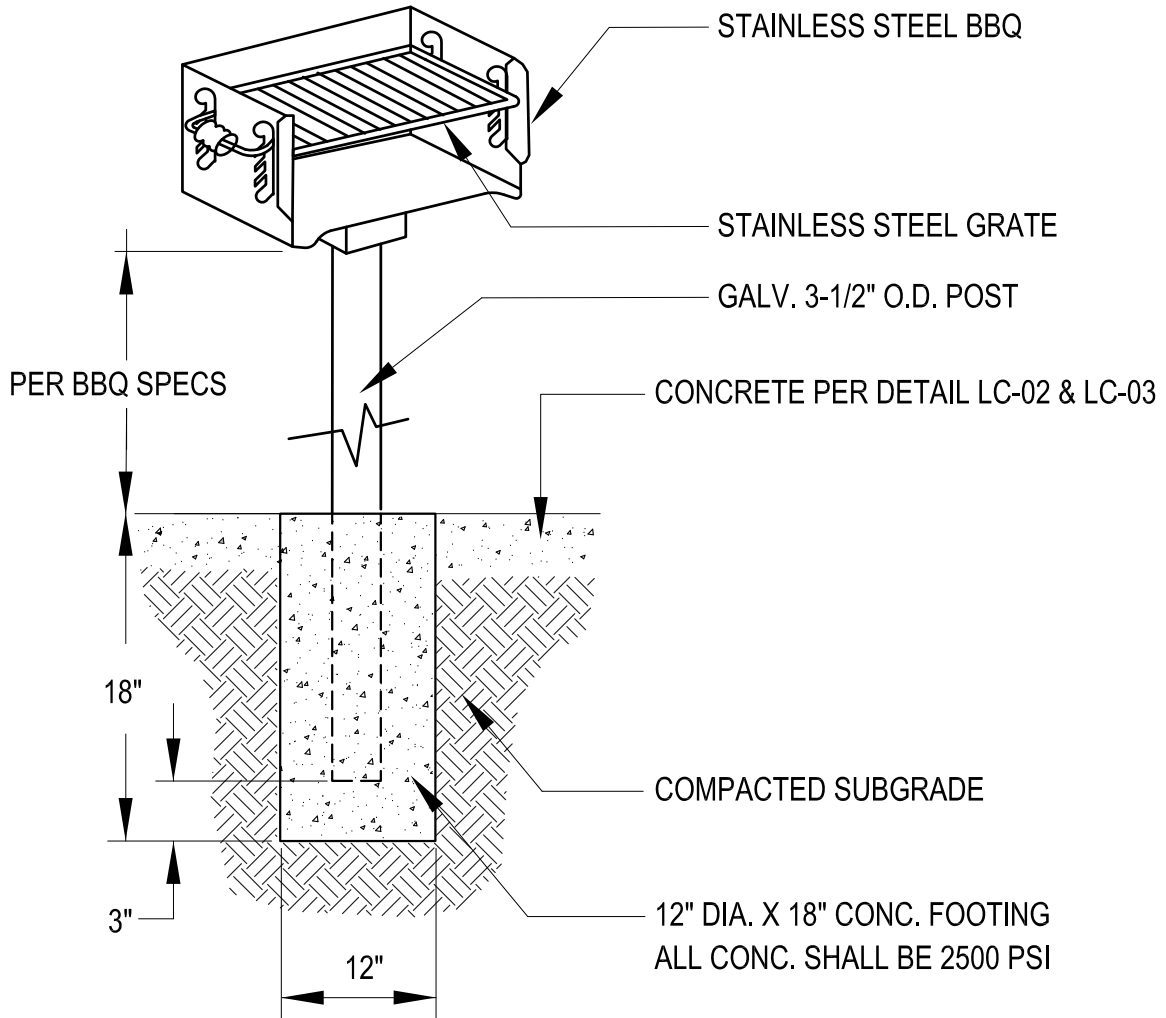

NOTES:

CONTACT RJ THOMAS MFG. CO., INC. @ (800) 762-5002

BBQ MUST HAVE A 4'X4' CONCRETE PAD 4" THICK PER CONCRETE DETAIL LC-02

BBQ SHALL BE FOOTING MOUNT

BBQ SHALL BE INSTALLED LEVEL AND PLUMB TO GRADE

LD Consulting 2012 (Any deviation or reproduction of this design must be approved in writing by Valley-Wide Recreation & Park District)



VALLEY-WIDE RECREATION & PARK DISTRICT

PARK BBQ

LC-34

REV. 2012