



**VALLEY-WIDE RECREATION
AND PARK DISTRICT
GoRecreation.org**

AWARD WINNING CALIFORNIA PARKS

Riverside County
Hemet, California

**DIAMOND VALLEY LAKE COMMUNITY PARK
DEDICATION WALL AND PICKLEBALL COURT IMPROVEMENTS**

2018

Contents:

Specifications – Notice Inviting Bids – Bidding Requirements – Bid Forms –
Contract Forms – Conditions of Contract

Board of Directors:

Matthew Duarte, President
John Bragg, Vice President
Steve Simpson, Secretary
Nick Schouten, Director
Jan Bissell, Director

District Administration:

Dean Wetter, General Manager

TABLE OF CONTENTS

<u>BIDDING REQUIREMENTS</u>	<u>PAGE</u>
Notice Inviting Bids	NIB-1 thru 3
Instructions to Bidders	B-1 thru B-8
Bid Bond	BB-1 thru BB-2
Bidding Sheets & Equipment & Material List <i>(submit with bid)</i>	BS-1 thru BS-8
Bidder's Experience Record & Resumes <i>(submit with bid)</i>	BR-1 thru BR-8
Proposal (10 day) <i>(submit with bid)</i>	C3-1
Designation of Subcontractors <i>(submit with bid)</i>	C5(a) thru C5-(e)
Contractor's Licensing Statement <i>(submit with bid)</i>	C6-1
Non-Collusion Declaration <i>(submit with bid)</i>	C7-1
Contract	C8(a) thru C8(b)
Performance Bond	C9-1 thru C9-4
Payment Bond	C10-1 thru C10-4
Worker's Compensation Insurance Certificate	C11-1
Certificate of Insurance Memorandum	C12-1
Iran Contracting Act Certification	C13-1
CalOsha Form 300A	C16-1 thru C16-2
Contractors CalOsha Compliance History & SIC Code	C17-1 thru C17-2
Public Works Contractor Registration Form <i>(submit with bid)</i>	C22-1
 <u>GENERAL CONDITIONS</u>	
Section F- Labor & Construction Includes Exhibit A-Change Order Form	F-1 thru F-56
 <u>SPECIAL CONDITIONS</u>	
Special Conditions	SC-1 thru SC-53
 <u>PERMITS</u>	
Section H, Permits	H-1 thru H-2
 <u>CONTRACT DRAWINGS</u>	
Secton P- Standard Construction Drawings (list)	P-1
 <u>VALLEY-WIDE DETAILED PROVISIONS</u>	
Standard Specifications - Planting	
Standard Specifications - Irrigation	



VALLEY-WIDE RECREATION AND PARK DISTRICT
901 WEST ESPLANADE AVENUE ·
P.O. BOX 907
SAN JACINTO, CA 92582
PHONE (951) 654-1505 · FAX (951) 654-5279

**DIAMOND VALLEY LAKE COMMUNITY PARK
DEDICATION WALL AND PICKLEBALL COURT IMPROVEMENTS**

NOTICE INVITING BIDS

RECEIPT AND OPENING OF PROPOSALS: Sealed bids will be received in the main office of the Valley-Wide Recreation & Park District (“District”), 901 West Esplanade Avenue, San Jacinto, CA 92582 until **Wednesday, September 5, 2018**, at **10:00a.m.**, at which time or soon thereafter said bids will be opened and publically read aloud. Bids received after this time will be returned unopened. Bids shall be valid for sixty (60) calendar days after the bid opening date. Bids must be submitted on the District’s Bid Forms. No electronic bids, or email bids will be accepted.

SCOPE OF WORK

Dedication Wall – Provide new concrete flat work, poured in place monument wall structure, benches, tables, lighting, flag pole, irrigation and landscape.

New Pickleball Court Expansion – Grading, concrete removal, new concrete, court surfacing, site amenities, fencing, and landscape and irrigation modifications.

MANDATORY PRE-BID WALK-THRU

Date: **Wednesday, August 8, 2018 at 9:30a.m.**

Location: **Diamond Valley Lake Community Park
1801 Angler Avenue, Hemet, CA 92543**

QUESTIONS: All questions must be submitted in writing by **5:00p.m. on Friday, August 17, 2018**, to Connie Jamerino at Connie@GoRecreation.org or FAX: 951-654-5279. **Questions received after this time may not be responded to.**

ENGINEERS ESTIMATE: \$208,000.00

COMPLETION OF WORK: All work shall be complete within **ninety (90)** calendar days after receipt of Notice-of-Acceptance-of-Proposal/Notice to Proceed. Liquidated damages of \$250.00 per calendar day will be assessed for exceeding any of the time completion requirements. Additional days will be given for days classified as “rain days” by the District Inspector.

PLANS AND SPECIFICATIONS: Specifications will be available to be reviewed on Valley-Wide Recreation and Park District website: www.GoRecreation.org/bids-and-documents **Tuesday, June 26, 2018.** Specification can also be reviewed free of charge at the Administration Department at: 901 W. Esplanade Avenue, San Jacinto California, 92582 (951) 654-1505. A non-refundable charge of **\$15.00** Dollars will be required of any bidder who requests that the Specifications be mailed.

Plans and Specifications are also available for examination at:

Bid America

41085 Elm Street
Murrieta, CA 92562
Tel: (951) 572-3379
FAX: (951) 677-4814
planroom@bidamerica.com

AGC Planroom

6212 Ferris Square
San Diego, CA 92121
Tel: (858) 558-7444
Attn: RaeMarie
planroom@agcsd.org

GUARANTEE: Bids must be accompanied by cash, a certified or cashier's check or a Bid Bond in favor of the Valley-Wide Recreation and Park District in an amount not less than ten percent (10%) of the submitted Total Bid Price, as a guarantee that the bidder will enter into the contract for the work, the full amount of such guarantee to be forfeited to the District should successful bidder fail to enter into said contract as set forth in Section 20160 et seq. of the Public Contract Code of the State of California.

SECURITY: Each bid shall be accompanied by the security referred to in the Contract Documents, the non-collusion affidavit, the list of proposed subcontractor, and all additional documentation required by the Instructions to Bidders. The successful bidder will be required to furnish the District with a Performance Bond equal to 100% of the successful bid, and Payment Bond equal to 100% of the successful bid, prior to execution of the Contract. All bonds are to be obtained from a surety that meets all the State of California bonding requirements, as defined in Code of Civil Procedure Section 995.120, and is admitted by the State of California. Pursuant of Public Contract Code Section 22300, the successful bidder may substitute certain securities for funds withheld by District to ensure his performance under the Contract.

INSURANCE: The successful bidder will also be required to furnish the District with an insurance policy as specified in the Specifications.

PREVAILING WAGE RATES: The Director of Industrial Relations (DIR) has determined the general prevailing rate per diem wages in the locality in which this work is to be performed for each craft or type of worker needed to execute the Contract which will be awarded to the successful bidder, copies of which are on file and will be made available to any interested party upon request at the main office or online at <http://www.dir.ca.gov/dlsr>. A copy of these rates shall be posted by the successful bidder at the job site. The successful bidder, and all subcontractor(s) under him, shall comply with all applicable Labor Code provisions, which include, but are not limited to the payment of not less than the required prevailing rates to all hours of labor and the debarment of contractors and subcontractors.

Pursuant to Labor Code sections 1725.5 and 1771.1, all contractors and subcontractors that wish to bid on, be listed in a bid proposal, or enter into a contract to perform public work must be registered with the Department of Industrial Relations. No Bid will be accepted nor any contract entered into without proof of the contractor's and subcontractors' current registration with the Department of Industrial Relations to perform public work. If awarded a contract, the Bidder and its subcontractors, of any tier, shall

maintain active registration with the Department of Industrial Relations for the duration of the Project.

CONTRACT TIME: No bid or bid security may be withdrawn for **seventy-five (75)** calendar days after the date bids are received. The successful bidder shall within **fifteen (15)** calendar days after the District mails a Notice of Acceptance of bid, return the signed contract and bonds, and attend the pre-construction conference at the District's Administration office. **The contract period shall commence fifteen (15) calendar days from the date of the Notice-of-Acceptance-of-Proposal/Notice to Proceed. The Contractor shall complete all work including testing, within ninety (90) Calendar days.**

REQUIRED CONTRACTOR LICENSE: Bidders on this work will be required to be licensed by the State of California as **B-1 or C-27** at the time of the bid and at the time of award as such license is defined in Section 7056 and/or Section 7058 of the Business and Professional Code and Section 732 of the California Administrative Code.

AWARD OF CONTRACT: The District shall award the Contract for the Project to the lowest responsible bidder as determined from the base bid alone by the district. The District reserves the right to reject any or all bids or to waive an irregularities or information in any bids or in the bidding process.

CERTIFIED PAYROLL: The winning bid contractor will be required to submit weekly certified payroll with their monthly invoice payment request. The District's invoice payment policy is thirty (30) days.

ADDITIONAL INFORMATION: All inquiries shall be directed to Connie Jamerino at Connie@GoRecreation.org or at (951) 654-1505.

Dated this 26 day of June 2018



Dean Wetter, General Manager
Valley-Wide Recreation & Park District

Posted date: June 26, 2018

INSTRUCTIONS TO BIDDERS

B-01. SECURING DOCUMENTS

Bids must be submitted to the District on the Bid Forms which are a part of the Bid Package for the Project. Bid and Contract Documents may be obtained from the Administration office at: 901 W. Esplanade Avenue, San Jacinto California, 92582 or www.GoRecreation.org/bids-and-documents any time after June 26, 2018. Prospective bidders are encouraged to telephone in advance to determine the availability of Contract Documents. Any charge for the Contract Documents is stated in the Notice Inviting Bids.

The District may also make the Contract Documents available for review at one or more plan rooms, as indicated in the Notice Inviting Bids. Please Note: Prospective Bidders who choose to review the Contract Documents at a plan room must contact the District to obtain the required Contract Documents if they decide to submit a bid for the Project.

Any Addenda will be posted on www.GoRecreation.org/bids-and-documents. Failure to acknowledge addenda may make a bid nonresponsive and not eligible for award of the contract.

B-02. EXAMINATION OF SITE AND CONTRACT DOCUMENTS

At its own expense and prior to submitting its Bid, each Bidder shall visit the site of the proposed work and fully acquaint itself with the conditions relating to the construction and labor required so that the Bidder may fully understand the work, including but not limited to difficulties and restrictions attending the execution of the work under the contract. Each Bidder shall carefully examine the Drawings, and shall read the Specifications, Contract, and all other documents referenced herein. Each Bidder shall also determine the local conditions which may in any way affect the performance of the work, including local tax structure, contractors' licensing requirements, availability of required insurance, the prevailing wages and other relevant cost factors, shall familiarize itself with all federal, state and local laws, ordinances, rules, regulations and codes affecting the performance of the work, including the cost of permits and licenses required for the work, and shall make such surveys and investigations, including investigations of subsurface or latent physical conditions at the site or where work is to be performed as may be required. Bidders are responsible for consulting the standards referenced in the Contract. The failure or omission of any Bidder to receive or examine any contract documents, forms, instruments, addenda, or other documents, or to visit the site and acquaint itself with conditions there existing shall in no way relieve any Bidder from any obligation with respect to its Bid or to the contract and no relief for error or omission will be given except as required under State law. The submission of a Bid shall be taken as conclusive evidence of compliance with this Article.

B-03. INTERPRETATION OF DRAWINGS AND DOCUMENTS

Prospective Bidders unclear as to the true meaning of any part of the Drawings, Specifications or other proposed contract documents may submit to the Engineer of the District a written request for interpretation. The prospective Bidder submitting the request is responsible for prompt delivery. Interpretation of the Drawings, Specifications or other proposed contract documents will be made only by a written addendum duly issued and a copy of such addenda will be mailed or delivered to each prospective Bidder who has purchased a set of Drawings and Specifications. The District will not be responsible for any other explanation or interpretations of the proposed documents. If a Prospective Bidders becomes aware of any errors or omissions in any part of the Contract Documents, it is the obligation of the Prospective Bidder to promptly bring it to the attention of

the District.

B-04. PRE-BID CONFERENCE

A Mandatory Pre-Bid Walk-Thru is scheduled for **Wednesday, August 8, 2018 at 9:30a.m.** to review the Project's existing conditions at **Diamond Valley Lake Community Park: 1801 Angler Avenue, Hemet, CA 92543**. Representatives of the District and consulting engineers, if any, will be present. Questions asked by Bidders at the Pre-Bid Conference not specifically addressed within the Contract Documents shall be answered in writing, and shall be sent to all Bidders present at the Pre-Bid Conference. **Bids will not be accepted from any bidder who did not attend the mandatory Pre-Bid Conference.**

B-05. ADDENDA

The District reserves the right to revise the Contract Documents prior to the Bid opening date. Revisions, if any, shall be made by written Addenda. All Addenda issued by the District shall be included in the Bid and made part of the Contract Documents. Pursuant to Public Contract Code Section 4104.5, if the District issues an Addendum which includes material changes to the Project less than 72 hours prior to the deadline for submission of Bids, the District will extend the deadline for submission of Bids. The District may determine, in its sole discretion, whether an Addendum warrants postponement of the Bid submission date. Each prospective Bidder shall provide District a name, address, email address, and facsimile number to which Addenda may be sent, as well as a telephone number by which the District can contact the Bidder. Copies of Addenda will be furnished by email, facsimile, first class mail, express mail or other proper means of delivery without charge to all parties who have obtained a copy of the Contract Documents and provided such current information. Please Note: Bidders are responsible for ensuring that they have received any and all Addenda. To this end, each Bidder should contact Connie Jamerino at (951) 654-1505 to verify that it has received all Addenda issued, if any, prior to the Bid opening. The Bidder shall indicate the Addenda received prior to bidding in the space provided in the Bid Form. Failure to indicate all Addenda may be sufficient cause for rejecting the Bid.

B-06. ALTERNATE BIDS

If alternate bid items are called for in the Contract Documents, the time required for completion of the alternate bid items has already been factored into the Contract duration and no additional Contract time will be awarded for any of the alternate bid items. The District may elect to include one or more of the alternate bid items, or to otherwise remove certain work from the Project scope of work. Accordingly, each bidder must ensure that each bid item contains a proportionate share of profit, overhead, and other costs or expenses which will be incurred by the bidder.

B-07. COMPLETION OF BID FORMS

Bids shall only be prepared using copies of the Bid Forms which are included in the Contract Documents. The use of substitute Bid Forms other than clear and correct photocopies of those provided by the District will not be permitted. Bids shall be executed by an authorized signatory as described in these Instructions to Bidders. In addition, Bidders shall fill in all blank spaces (including inserting "N/A" where applicable), and initial all interlineations, alterations, or erasures to the Bid Forms. Bidders shall neither delete, modify, nor supplement the printed matter on the Bid Forms nor make substitutions thereon. **USE OF BLACK OR BLUE INK, INDELIBLE PENCIL, OR A TYPEWRITER IS REQUIRED.** Deviations in the Bid Forms may result in the Bid being deemed non-responsive.

B-08. MODIFICATIONS OF BIDS

Each Bidder shall submit its Bid in strict conformity with the requirements of the Contract Documents. Unauthorized additions, modifications, revisions, conditions, limitations, exclusions or provisions attached to a Bid may render it non-responsive and may cause its rejection. Bidders shall not delete, modify, or supplement the printed matter on the Bid Forms, or make substitutions thereon. Oral, telephonic and electronic modifications will not be considered.

B-09. SUBCONTRACTORS

Bidder shall set forth the name, address of the place of business, and contractor license number of each subcontractor who will perform work, labor, furnish materials or render services to the bidder on said contract and each subcontractor licensed by the State of California who, under subcontract to bidder, specially fabricates and installs a portion of the Work described in the Drawings and Specifications in an amount in excess of one half of one percent (0.5%) of the total bid price, and shall indicate the portion of the work to be done by such subcontractor in accordance with Public Contract Code Section 4104.

B-10. LICENSING REQUIREMENTS

Pursuant to Business and Professions Code Section 7028.15 and Public Contract Code Section 3300, all bidders must possess proper licenses for performance of this Contract. Subcontractors must possess the appropriate licenses for each specialty subcontracted. Pursuant to Business and Professions Code Section 7028.5, the District shall consider any bid submitted by a contractor not currently licensed in accordance with state law and pursuant to the requirements found in the Contract Documents to be nonresponsive, and the District shall reject the Bid. The District shall have the right to request, and Bidders shall provide within ten (10) calendar days, evidence satisfactory to the District of all valid license(s) currently held by that Bidder and each of the Bidder's subcontractors, before awarding the Contract.

Notwithstanding anything contained herein, if the Work involves federal funds, the Contractor shall be properly licensed by the time the Contract is awarded, pursuant to the provisions of Public Contract Code section 20103.5.

B-11. BID GUARANTEE (BOND)

Each bid shall be accompanied by: (a) cash; (b) a certified or cashier's check made payable to Valley-Wide Recreation and Park District; or (c) a Bid Bond secured from a surety company satisfactory to the District, the amount of which shall not be less than ten percent (10%) of the Total Bid Price, made payable to Valley-Wide Recreation and Park District as bid security. Personal sureties and unregistered surety companies are unacceptable. The surety insurer shall be California admitted surety insurer, as defined in Code of Civil Procedure Section 995.120. The bid security shall be provided as a guarantee that within ten (10) working days after the District provides the successful bidder the Notice of Award, the successful bidder will enter into a contract and provide the necessary bonds and certificates of insurance. The bid security will be declared forfeited if the successful bidder fails to comply within said time, and District may enter into a contract with the next lowest responsive responsible bidder, or may call for new bids. No interest shall be paid on funds deposited with the District. District will return the security accompanying the bids of all unsuccessful bidders no later than 60 calendar days after award of the contract.

B-12. IRAN CONTRACTING ACT OF 2010

In accordance with Public Contract Code Section 2200 *et seq.*, the District requires that any person that submits a bid or proposal or otherwise proposes to enter into or renew a contract with the District with respect to goods or services of one million dollars (\$1,000,000) or more,

certify at the time the bid is submitted or the contract is renewed, that the person is not identified on a list created pursuant to subdivision (b) of Public Contract Code Section 2203 as a person engaging in investment activities in Iran described in subdivision (a) of Public Contract Code Section 2202.5, or as a person described in subdivision (b) of Public Contract Code Section 2202.5, as applicable.

The form of such Iran Contracting Certificate is included with the bid package and must be signed and dated under penalty of perjury.

B-13. NON-COLLUSION DECLARATION

Bidders on all public works contracts are required to submit a declaration of non-collusion with their bid. This form is included with the bid package and must be signed and dated under penalty of perjury.

B-14. PUBLIC WORKS CONTRACTOR REGISTRATION CERTIFICATION

Pursuant to Labor Code sections 1725.5 and 1771.1, all contractors and subcontractors that wish to bid on, be listed in a bid proposal, or enter into a contract to perform public work must be registered with the Department of Industrial Relations. No bid will be accepted nor any contract entered into without proof of the contractor's and subcontractors' current registration with the Department of Industrial Relations to perform public work. If awarded a contract, the bidder and its subcontractors, of any tier, shall maintain active registration with the Department of Industrial Relations for the duration of the Project. To this end, Bidder shall sign and submit with its Bid the Public Works Contractor Registration Certification on the form provided, attesting to the facts contained therein. Failure to submit this form may render the bid non-responsive. In addition, each Bidder shall provide the registration number for each listed subcontractor in the space provided in the Designation of Subcontractors form.

B-15. BIDDER INFORMATION AND EXPERIENCE FORM

Each Bidder shall complete the questionnaire provided herein and shall submit the questionnaire along with its Bid. Failure to provide all information requested within the questionnaire along with the Bid may cause the bid to be rejected as non-responsive. The District reserves the right to reject any Bid if an investigation of the information submitted does not satisfy the Engineer that the Bidder is qualified to properly carry out the terms of the contract.

B-16. WORKERS' COMPENSATION CERTIFICATION

In accordance with the provisions of Labor Code Section 3700, Contractor shall secure the payment of compensation to its employees. Contractor shall sign and file with the District the following certificate prior to performing the work under this Contract:

I am aware of the provisions of Section 3700 of the Labor Code, which require every employer to be insured against liability for workers' compensation or to undertake self-insurance in accordance with the provisions of that code, and I will comply with such provisions before commencing the performance of the work of this contract.

The form of such Workers' Compensation Certificate is included as part of this document.

B-17. SIGNING OF BIDS

All Bids submitted shall be executed by the Bidder or its authorized representative. Bidders may be asked to provide evidence in the form of an authenticated resolution of its Board of Directors or a Power of Attorney evidencing the capacity of the person signing the Bid to bind

the Bidder to each Bid and to any Contract arising therefrom.

If a Bidder is a joint venture or partnership, it may be asked to submit an authenticated Power of Attorney executed by each joint venturer or partner appointing and designating one of the joint venturers or partners as a management sponsor to execute the Bid on behalf of Bidder. Only that joint venturer or partner shall execute the Bid. The Power of Attorney shall also: (1) authorize that particular joint venturer or partner to act for and bind Bidder in all matters relating to the Bid; and (2) provide that each venturer or partner shall be jointly and severally liable for any and all of the duties and obligations of Bidder assumed under the Bid and under any Contract arising therefrom. The Bid shall be executed by the designated joint venturer or partner on behalf of the joint venture or partnership in its legal name.

B-18. SUBMISSION OF SEALED BIDS

Once the Bid and supporting documents have been completed and signed as set forth herein, they shall be placed, along with the Bid Guarantee and other required materials, in a sealed envelope, addressed and delivered or mailed, postage prepaid, to the Engineering Department of the District before the time and day set for the receipt of bids. The envelope shall bear the title of the work and the name of the bidder. No oral or telephonic bids will be considered. No forms transmitted via the internet, e-mail, facsimile, or any other electronic means will be considered unless specifically authorized by the District as provided herein. Bids received after the time and day set for the receipt of bids shall be returned to the bidder unopened. The envelope shall also contain the following in the lower left-hand corner thereof:

**Bid of _____ (Bidder's Name)
for the DIAMOND VALLEY LAKE COMMUNITY PARK DEDICATION WALL AND
PICKLEBALL COURT IMPROVEMENTS**

Only where expressly permitted in the Notice Inviting Bids may bidders submit their bids via electronic transmission pursuant to Public Contract Code sections 1600 and 1601. Any acceptable method(s) of electronic transmission shall be stated in the Notice Inviting Bids. District may reject any bid not strictly complying with District's designated methods for delivery.

B-19. OPENING OF BIDS

At the time and place set for the opening and reading of bids, or any time thereafter, each and every bid received prior to the time and day set for the receipt of bids will be publicly opened and read. The District will leave unopened any Bid received after the specified date and time, and any such unopened Bid will be returned to the bidder. It is the bidder's sole responsibility to ensure that its Bid is received as specified. Bids may be submitted earlier than the date(s) and time(s) indicated.

The public reading of each bid will include the following information:

- A. The name and business location of the bidder.
- B. The nature and amount of the bid security furnished by bidder.
- C. The bid amount.

Bidders or their representatives and other interested persons may be present at the opening of the bids. The District may, in its sole discretion, elect to postpone the opening of the submitted Bids. The District reserves the right to reject any or all Bids and to waive any informality or

irregularity in any Bid.

B-20. WITHDRAWAL OF BID

Any bid may be withdrawn either personally or by written request, incurring no penalty, at any time prior to the scheduled closing time for receipt of bids. Requests to withdraw bids shall be worded so as not to reveal the amount of the original bid. Withdrawn bids may be resubmitted until the time and day set for the receipt of bids, provided that resubmitted bids are in conformance with the instructions herein.

Bids may be withdrawn after bid opening only by providing written notice to District within five (5) working days of the bid opening and in compliance with Public Contract Code Section 5100 *et seq.*, or as otherwise may be allowed with the consent of the District.

B-21. BIDDERS INTERESTED IN MORE THAN ONE BID

No Bidder shall be allowed to make, file or be interested in more than one bid for the same work unless alternate bids are specifically called for. A person, firm or corporation that has submitted a sub-proposal to a Bidder, or that has quoted prices of materials to a Bidder, is not thereby disqualified from submitting a sub-proposal or quoting prices to other bidders. No person, firm, corporation, or other entity may submit a sub-proposal to a Bidder, or quote prices of materials to a Bidder, when also submitting a prime Bid on the same Project.

B-22. SUBSTITUTION OF SECURITY

The Contract Documents call for monthly progress payments based upon the percentage of the Work completed. The District will retain a percentage of each progress payment as provided by the Contract Documents. At the request and expense of the successful Bidder, the District will substitute securities for the amount so retained in accordance with Public Contract Code Section 22300.

B-23. PREVAILING WAGES

The District has obtained from the Director of the Department of Industrial Relations the general prevailing rate of per diem wages in the locality in which this work is to be performed for each craft or type of worker needed to execute the Contract. These rates are available at the Administration Office of the District or may be obtained online at <http://www.dir.ca.gov>. Bidders are advised that a copy of these rates must be posted by the successful Bidder at the job site(s).

B-24. DEBARMENT OF CONTRACTORS AND SUBCONTRACTORS

In accordance with the provisions of the Labor Code, contractors or subcontractors may not perform work on a public works project with a subcontractor who is ineligible to perform work on a public project pursuant to Labor Code Sections 1777.1 or 1777.7. Any contract on a public works project entered into between a contractor and a debarred subcontractor is void as a matter of law. A debarred subcontractor may not receive any public money for performing work as a subcontractor on a public works contract. Any public money that is paid to a debarred subcontractor by the Contractor for the Project shall be returned to the District. The Contractor shall be responsible for the payment of wages to workers of a debarred subcontractor who has been allowed to work on the Project.

B-25. INSURANCE REQUIREMENTS

Prior to commencing work, the successful bidder shall purchase and maintain insurance as set forth in the General Conditions.

B-26. PERFORMANCE BOND AND PAYMENT BOND REQUIREMENTS

The successful bidder will be required to furnish a Labor and Material Payment Bond and a Faithful Performance Bond each in an amount equal to one hundred percent (100%) of the contract price. Each bond shall be secured from a surety company that meets all State of California bonding requirements, as defined in California Code of Civil Procedure Section 995.120 and is admitted by the State of California. Each bond shall be accompanied, upon the request of District, with all documents required by California Code of Civil Procedure Section 995.660 to the extent required by law. All bonding and insurance requirements shall be completed and submitted to District within ten (10) working days from the date the District provides the successful bidder with the Notice of Award.

B-27. SALES AND OTHER APPLICABLE TAXES, PERMITS, LICENSES AND FEES

Contractor and its subcontractors performing work under this Contract will be required to pay California sales tax and other applicable taxes, and to pay for permits, licenses and fees required by the agencies with authority in the jurisdiction in which the Work will be located, unless otherwise expressly provided by the Contract Documents.

B-28. PERMIT AND INSPECTION FEE ALLOWANCE

Notwithstanding anything contained herein, the Bid Form contains an allowance for the Contractor's cost of acquiring traffic control permits and for construction inspection fees that may be charged to the Contractor by the Agency of Jurisdiction. The allowance is included within the Bid Form to eliminate the need by bidders to research or estimate the costs of traffic control permits and construction inspection fees prior to submitting a bid. The allowance is specifically intended to account for the costs of traffic control permits and construction inspection fees charged by the local Agency of Jurisdiction only. No other costs payable by Contractor to the Agency of Jurisdiction are included within the allowance.

B-29. FILING OF BID PROTESTS

Bidders may file a "protest" of a Bid with the District's General Manager, Dean Wetter. In order for a Bidder's protest to be considered valid, the protest must:

- D. Be filed in writing within five (5) calendar days after the bid opening date;
- E. Clearly identify the specific irregularity or accusation;
- F. Clearly identify the specific District staff determination or recommendation being protested;
- G. Specify in detail the grounds for protest and the facts supporting the protest; and
- H. Include all relevant, supporting documentation with the protest at time of filing.

If the protest does not comply with each of these requirements, the District may reject the protest without further review.

If the protest is timely and complies with the above requirements, the District's General Manager or other designated District staff member, shall review the protest, any response from the challenged Bidder(s), and all other relevant information. The General Manager will provide a written decision to the protestor.

The procedure and time limits set forth in this Article are mandatory and are the sole and

exclusive remedy in the event of a Bid protest. Failure to comply with these procedures shall constitute a failure to exhaust administrative remedies and a waiver of any right to further pursue the Bid protest, including filing a Government Code Claim or legal proceedings.

B-30. BASIS OF AWARD; BALANCED BID

The District shall award the Contract to the lowest responsible Bidder submitting a responsive Bid. The lowest Bid will be determined on the basis of the Total Bid Price.

The District may reject any Bid which, in its opinion when compared to other Bids received or to the District's internal estimates, does not accurately reflect the cost to perform the Work. The District may reject as non-responsive any Bid which unevenly weights or allocates costs, including but not limited to overhead and profit to one or more particular bid items.

B-31. AWARD PROCESS

Once all Bids are opened and reviewed to determine the lowest responsive and responsible Bidder, the District Board may award the contract. The apparent successful Bidder should begin to prepare the following documents: (1) the Performance Bond; (2) the Payment Bond; and (3) the required insurance certificates and endorsements. Once the District notifies the Bidder of the award, the Bidder will have ten (10) working days from the date of this notification to execute the Contract and supply the District with all of the required documents and certifications. Regardless of whether the Bidder supplies the required documents and certifications in a timely manner, the Contract time will begin to run twenty (20) working days from the date of the notification. Once the District receives all of the properly drafted and executed documents and certifications from the Bidder, the District shall issue a Notice to Proceed to that Bidder.

B-32. EXECUTION OF CONTRACT

As required herein the Bidder to whom an award is made shall execute the Contract in the amount determined by the Contract Documents. The District may require appropriate evidence that the persons executing the Contract are duly empowered to do so. The Contract and bond forms to be executed by the successful Bidder are included within these Specifications and shall not be detached.

B-33. QUESTIONS

Questions regarding this Notice Inviting Bids may be directed to Connie Jamerino at (951) 654-1505 or email at Connie@GoRecreation.org. No other members of the District's staff or District Board should be contacted about this procurement during the bidding process. Any and all inquiries and comments regarding this Bid must be communicated in writing, unless otherwise instructed by the District. The District may, in its sole discretion, disqualify any Bidder who engages in any prohibited communications.

VALLEY-WIDE RECREATION BID BOND

Bid Bond No.

KNOW ALL MEN BY THESE PRESENTS, that we _____
(Here insert full name and address or legal title of Contractor)

_____ as Principal, hereinafter called the Principal, and

_____ (Here insert full name and address or legal title of Surety)

A corporation duly organized under the laws of the State of _____ as Surety, Hereinafter call the Surety, are held and firmly bound unto Valley-Wide Recreation.

Obligee, hereinafter all the Obligee, in the sum of _____

_____ Dollars (_____), for the payment of which sum well and truly to be made, the said Principal and the said Surety, bind ourselves, our heir, executors, administrator, successors and assigns, jointly and severally firmly by these presents.

WHEREAS, the Principal has submitted a bid, dated _____, 20____, for _____

_____ (Here insert full name, address and description of Project)

NOW, THEREFORE, IF THE Obligee shall accept the bid of the Principal and the Principal shall enters into a Contracto with the Obligee in accordance with the terms of such bid, and give such bond or bonds as may be specified in the bidding of Contract Documents with good and sufficient surety for the faithful performance of such Contract and for the prompt payment of labor and material furnished in the prosecution thereof, or in the event of the failure of the Principal to enter such Contract and give such bond or bonds, if the Principal shall pay the Obligee the difference not to exceed the penalty hereof between the amount specified in said bid and such larger amount for which the Obligee may in good faith contract with another party to perform the Work covered by said bid, then this obligation shall be null and void, otherwise to remain in full force and effect.

In the event suit is brought upon this Bond by Obligee and judgement is recovered , the Surety shall pay all costs incurred by Obligee in such suits to be fixed by the court.

Signed and sealed this _____ day of _____, _____

(Witness)

(Principal)

(Title)

(Witness)

(Surety)

(Title)

The Bid Bond (BB-1) form shall be submitted to be considered a responsive bid

**Notary Public Acknowledgement required for Surety
Per Civil Code 1189 a notice must be legible and provided at the top in an enclosed box to be deemed responsible**

VALLEY-WIDE RECREATION
DIAMOND VALLEY LAKE COMMUNITY PARK
DEDICATION WALL AND PICKLEBALL COURT IMPROVEMENTS

BID FORMS

Bid will be received at the Valley-Wide Recreation and Park District office, located at 901 W. Esplanade Avenue, San Jacinto, California, until **Wednesday, September 5, 2018 at 10:00a.m.**

NAME OF BIDDER: _____

To the Board of Directors
of the Valley-Wide Recreation and Park District
901 W. Esplanade Avenue
San Jacinto, California 92581

The undersigned, hereby declare that we have carefully examined the location of the proposed Work, and have read and examined the Contract Documents, including all plans, specifications, and all addenda, if any, for the following Project:

DIAMOND VALLEY LAKE COMMUNITY PARK
DEDICATION WALL AND PICKLEBALL COURT IMPROVEMENTS

We hereby propose to furnish all labor, materials, equipment, tools, transportation, and services, and to discharge all duties and obligations necessary and required to perform and complete the Project for the following TOTAL BID PRICE: _____

The undersigned acknowledge receipt, understanding, and full consideration of the following addenda to the Contract Documents:

Addenda No. _____

1. Attached is the required Bid Guarantee in the amount of not less than 10% of the Total Bid Price.
2. Attached is the complete Designation of Subcontractors form.
3. Attached is the fully executed Non-collusion Declaration form.
4. Attached is the completed Iran Contracting Act Certification form.
5. Attached is the complete Public Works Contractor Registration Certification form.
6. Attached is the completed Contractor's Certificate Regarding Workers' Compensation form.
7. Attached is the completed Bidder Information and Experience form.

**VALLEY-WIDE RECREATION
DIAMOND VALLEY LAKE COMMUNITY PARK
DEDICATION WALL AND PICKLEBALL COURT IMPROVEMENT**

**BIDDING SHEET
(Dedication Wall)**

Bid Item	QTY	Unit	Description Unit Price Written in Words	Unit Price (Figures)	Total Amount (Figures)
1	1	LS	Saw cut and remove existing sidewalk panels for new piping irrigation and electrical _____ (words)	\$ _____	\$ _____
2	1	LS	Site preparation and sub-grading _____ (words)	\$ _____	\$ _____
3	1832	SF	New 4" thick concrete _____ (words)	\$ _____	\$ _____
4	1	LS	Monument Wall PIP Concrete (no granite or lettering) _____ (words)	\$ _____	\$ _____
5	1	LS	Site electric including flag and wall fixtures _____ (words)	\$ _____	\$ _____
6	3	EA	Decorative concrete bench _____ (words)	\$ _____	\$ _____
7	2	LF	Decorative concrete table _____ (words)	\$ _____	\$ _____
8	1	LS	Irrigation _____ (words)	\$ _____	\$ _____
9	30	LF	Landscape (MOWCURB) _____ (words)	\$ _____	\$ _____

**VALLEY-WIDE RECREATION
DIAMOND VALLEY LAKE COMMUNITY PARK
DEDICATION WALL AND PICKLEBALL COURT IMPROVEMENT**

**BIDDING SHEET
(Dedication Wall)**

Bid Item	QTY	Unit	Description Unit Price Written in Words	Unit Price (Figures)	Total Amount (Figures)
10	2	EA	Landscape (36" Box Tree) _____ (words)	\$ _____	\$ _____
11	12	EA	Landscape (15 Gallon Shrub) _____ (words)	\$ _____	\$ _____
12	70	EA	Landscape (5 Gallon Shrub) _____ (words)	\$ _____	\$ _____
13	110	EA	Landscape (1 Gallon Shrub) _____ (words)	\$ _____	\$ _____
14	7	EA	Landscape (Boulders) _____ (words)	\$ _____	\$ _____
15	1000	SF	Landscape (Soil Prep & Finish Grading) _____ (words)	\$ _____	\$ _____
16	1000	SF	Landscape (Mulch) _____ (words)	\$ _____	\$ _____

**VALLEY-WIDE RECREATION
DIAMOND VALLEY LAKE COMMUNITY PARK
DEDICATION WALL AND PICKLEBALL COURT IMPROVEMENT**

**BIDDING SHEETS
(Pickleball Court Improvements)**

Bid Item	QTY	Unit	Description Unit Price Written in Words	Unit Price (Figures)	Total Amount (Figures)
17	1	LS	Remove existing trees, roots, shrubs, concrete or other misc. materials _____ (words)	\$ _____	\$ _____
18	1	LS	Protect in place existing irrigation valves and piping _____ (words)	\$ _____	\$ _____
19	1	LS	Site preparation, grading and erosion control _____ (words)	\$ _____	\$ _____
20	1	LS	Field Survey and Staking _____ (words)	\$ _____	\$ _____
21	2	EA	4" Under sidewalk drain (3 pipes side by side) under new sidewalk _____ (words)	\$ _____	\$ _____
22	1	EA	3" Under sidewalk drain (3 pipes side by side) under existing sidewalk, including concrete removal and replacement and 3 EA curb cores per City of Hemet D-309 Standard Detail _____ (words)	\$ _____	\$ _____
23	1	EA	24"x24" Concrete Catch Basin _____ (words)	\$ _____	\$ _____
24	30	LF	Remove existing asphalt and install new concrete ribbon gutter to match existing _____ (words)	\$ _____	\$ _____

**VALLEY-WIDE RECREATION
DIAMOND VALLEY LAKE COMMUNITY PARK
DEDICATION WALL AND PICKLEBALL COURT IMPROVEMENT**

**BIDDING SHEETS
(Pickleball Court Improvements)**

Bid Item	QTY	Unit	Description Unit Price Written in Words	Unit Price (Figures)	Total Amount (Figures)
25	2	EA	Commercial Pickleball post. Install per manufacturer's specification. Provide net to VWRPD (4) _____ (words)	\$ _____	\$ _____
26	645	SF	4"- 8" Arizona river rock dry river deb (6) _____ (words)	\$ _____	\$ _____
27	1	EA	Trash Receptacle New Model #MRPQL32G & MRPQDTOM (9) _____ (words)	\$ _____	\$ _____
28	4,917	SF	3250 PSI concrete 6" thick over 3" CL II base with #4 rebar at 36" spacing. Scarify 12" deep prior to pouring (1) _____ (words)	\$ _____	\$ _____
29	4,917	SF	Pickleball court surfacing and striping per VWRPD Specs. Colors to match existing court (5) _____ (words)	\$ _____	\$ _____
30	140	LF	6"x6" concrete mowcurb with #3 rebar (7) _____ (words)	\$ _____	\$ _____
31	207	SF	3250 PSI concrete 4" thick over 3" Class II base with #4 rebar at 48" spacing. Scarify 12" deep prior to pouring (8) _____ (words)	\$ _____	\$ _____

**VALLEY-WIDE RECREATION
DIAMOND VALLEY LAKE COMMUNITY PARK
DEDICATION WALL AND PICKLEBALL COURT IMPROVEMENT**

**BIDDING SHEETS
(Pickleball Court Improvements)**

Bid Item	QTY	Unit	Description Unit Price Written in Words	Unit Price (Figures)	Total Amount (Figures)
32	292	LF	4' high chain link fence tp. With top and bottom rail post to be installed within 3" of concrete edge typ. (2) _____ (words)	\$ _____	\$ _____
33	2	EA	4' high x 5' wide double swing chain link gate (3) _____ (words)	\$ _____	\$ _____
34	1	EA	Irrigation System _____ (words)	\$ _____	\$ _____
35	2,494	SF	Soil Preparation and Weed abatement _____ (words)	\$ _____	\$ _____
36	1	EA	36" Box Tree _____ (words)	\$ _____	\$ _____
37	146	EA	5 Gallon Shrub _____ (words)	\$ _____	\$ _____
38	42	EA	1 Gallon Shrub _____ (words)	\$ _____	\$ _____
39	2,494	SF	4" Thick layer of Mulch _____ (words)	\$ _____	\$ _____

**VALLEY-WIDE RECREATION
DIAMOND VALLEY LAKE COMMUNITY PARK
DEDICATION WALL AND PICKLEBALL COURT IMPROVEMENT**

**BIDDING SHEETS
(Pickleball Court Improvements)**

Bid Item	QTY	Unit	Description Unit Price Written in Words	Unit Price (Figures)	Total Amount (Figures)
40	1	LS	Mobilization, Performance and Payment Bonds for Bid Items 1-39 (not to exceed 10%) _____ (words)	\$ PRESET	\$ _____
TOTAL BID AMOUNT _____ (words)					\$ _____

EQUIPMENT AND MATERIAL

No substitution will be permitted without written justification and the approval of the District prior to the bid opening.

PRODUCTS OF MANUFACTURERS LISTED AS EQUALS TO THOSE SPECIFIED IN THE CONTRACT DOCUMENTS MUST BE SUBMITTED FOR REVIEW AND APPROVAL BY THE DISTRICT NO LATER THAN THE TENTH (10TH) DAY PRECEDING THE DATE SET FOR RECEIPT OF BIDS.

VALLEY-WIDE RECREATION

**DIAMOND VALLEY LAKE COMMUNITY PARK
DEDICATION WALL AND PICKLE BALL COURT IMPROVEMENTS**

**BIDDER'S 3-YEAR EXPERIENCE
RECORD & RESUMES OF KEY PERSONNEL**

All bidders must provide a **detailed three (3) year** experience record showing successful completion, as a **Class B-1** General Contractor or **Class C-27** General Building, of at least three (3) similar projects within the last **three (3)** years as follows:

- 1. Public Works**
- 2. \$400,000 or greater contract value**
- 3. Owner occupied renovation projects**
- 4. Renovation of publicly accessible areas while maintaining public access for public administration buildings, hospitals, or schools.**

Additionally, bidders must include resumes of key personnel proposed to work on this project when submitting your bid. This information will be critical in determining the most responsible bidder.

Provide client reference contact information for each of the Projects submitted.

**Failure to submit any of the above-mentioned information with your bid
“may” deem your bid non-responsive**

VALLEY-WIDE RECREATION

DIAMOND VALLEY LAKE COMMUNITY PARK
DEDICATION WALL AND PICKLE BALL COURT IMPROVEMENTS

BIDDER'S 3-YEAR EXPERIENCE
RECORD & RESUMES OF KEY PERSONNEL

Bidder Information and Experience Form

ARTICLE 1. INFORMATION ABOUT BIDDER

(Indicate not applicable ("N/A") where appropriate.)

NOTE: Where Bidder is a joint venture, pages shall be duplicated and information provided for all parties to the joint venture.

1.0 Name of Bidder: _____

2.0 Type, if Entity: _____

3.0 Bidder Address: _____

Facsimile Number

Telephone Number

Email Address

4.0 How many years has Bidder's organization been in business as a Contractor?

5.0 How many years has Bidder's organization been in business under its present name? _____

5.1 Under what other or former names has Bidder's organization operated? _____

6.0 If Bidder's organization is a corporation, answer the following:

6.1 Date of Incorporation: _____

6.2 State of Incorporation: _____

6.3 President's Name: _____

6.4 Vice-President's Name(s): _____

6.5 Secretary's Name: _____

VALLEY-WIDE RECREATION

**DIAMOND VALLEY LAKE COMMUNITY PARK
DEDICATION WALL AND PICKLE BALL COURT IMPROVEMENTS**

**BIDDER'S 3-YEAR EXPERIENCE
RECORD & RESUMES OF KEY PERSONNEL**

6.6 Treasurer's Name: _____

7.0 If an individual or a partnership, answer the following:

7.1 Date of Organization: _____

7.2 Name and address of all partners (state whether general or limited partnership):

8.0 If other than a corporation or partnership, describe organization and name principals:

9.0 List other states in which Bidder's organization is legally qualified to do business.

10.0 What type of work does the Bidder normally perform with its own forces?

11.0 Has Bidder ever failed to complete any work awarded to it? If so, note when, where, and why:

12.0 Within the last five years, has any officer or partner of Bidder's organization ever been an officer or partner of another organization when it failed to complete a contract? If so, attach a separate sheet of explanation:

VALLEY-WIDE RECREATION

**DIAMOND VALLEY LAKE COMMUNITY PARK
DEDICATION WALL AND PICKLE BALL COURT IMPROVEMENTS**

**BIDDER'S 3-YEAR EXPERIENCE
RECORD & RESUMES OF KEY PERSONNEL**

13.0 List Trade References:

14.0 List Bank References (Bank and Branch Address):

15.0 Name of Bonding Company and Name and Address of Agent:

ARTICLE 2. LIST OF CURRENT PROJECTS (BACKLOG)

[**Duplicate Page if needed for listing additional current projects.**]

Project	Description of Bidder's Work	Completion Date	Cost of Bidder's Work

VALLEY-WIDE RECREATION

**DIAMOND VALLEY LAKE COMMUNITY PARK
DEDICATION WALL AND PICKLE BALL COURT IMPROVEMENTS**

**BIDDER'S 3-YEAR EXPERIENCE
RECORD & RESUMES OF KEY PERSONNEL**

ARTICLE 3. LIST OF COMPLETED PROJECTS – LAST THREE YEARS

[**Duplicate Page if needed for listing additional completed projects.**]

Please include only those projects which are similar enough to demonstrate Bidder's ability to perform the required Work.

Project	Description of Bidder's Work	Completion Date	Cost of Bidder's Work

VALLEY-WIDE RECREATION

**DIAMOND VALLEY LAKE COMMUNITY PARK
DEDICATION WALL AND PICKLE BALL COURT IMPROVEMENTS**

**BIDDER'S 3-YEAR EXPERIENCE
RECORD & RESUMES OF KEY PERSONNEL**

ARTICLE 4. EXPERIENCE AND TECHNICAL QUALIFICATIONS QUESTIONNAIRE

Personnel:

The Bidder shall identify the key personnel to be assigned to this project in a management, construction supervision or engineering capacity.

1. List each person's job title, name and percent of time to be allocated to this project:

2. Summarize each person's specialized education:

3. List each person's years of construction experience relevant to the project:

VALLEY-WIDE RECREATION

**DIAMOND VALLEY LAKE COMMUNITY PARK
DEDICATION WALL AND PICKLE BALL COURT IMPROVEMENTS**

**BIDDER'S 3-YEAR EXPERIENCE
RECORD & RESUMES OF KEY PERSONNEL**

4. Summarize such experience:

Bidder agrees that personnel named in this Bid will remain on this Project until completion of all relevant Work, unless substituted by personnel of equivalent experience and qualifications approved in advance by the District.

Changes Occuring Since Prequalification

If any substantive changes have occurred since Bidder submitted its prequalification package for this Project, Bidder shall list them below. If none are listed, Bidder certifies that no substantive changes have occurred.

Additional Bidder's Statements:

If the Bidder feels that there is additional information which has not been included in the questionnaire above, and which would contribute to the qualification review, it may add that information in a statement here or on an attached sheet, appropriately marked:

ARTICLE 5. VERIFICATION AND EXECUTION

These Bid Forms shall be executed only by a duly authorized official of the Bidder:

I declare under penalty of perjury under the laws of the State of California that the foregoing information is true and correct:

Name of Bidder _____

VALLEY-WIDE RECREATION
DIAMOND VALLEY LAKE COMMUNITY PARK
DEDICATION WALL AND PICKLE BALL COURT IMPROVEMENTS
BIDDER'S 3-YEAR EXPERIENCE
RECORD & RESUMES OF KEY PERSONNEL

Signature _____

Name _____

Title _____

Date _____

PROPOSAL

The undersigned hereby declares, as Bidder, that the only persons or parties interested in this proposal as principals are those named herein; that no director or any other officer or employee of the Valley-Wide Recreation District is in any manner interested directly or indirectly in this proposal or in the profits to be derived from the contract proposed to be taken; that this bid is made without any connection with any person or persons making a bid for the same purpose; that the bid is in all respects fair and without collusion or fraud; that he has read the Notice Inviting Bids (or Bidding Information) and the Instructions to Bidders and agrees to all the stipulations contained herein; that he proposes and agrees that if his bid as submitted in the attached sheets, be accepted he will contract in the form so approved and furnish the items called for in accordance with the provisions of said approved form of Agreement and the Specifications and to deliver the same within the time stipulated therein; and that he will accept in full payment therefore the prices named in said Bid Sheet.

The Bidder further agrees, that upon receipt of written notice of acceptance of the proposal with 60 days after the day of opening bids (unless otherwise specified in the Notice Inviting Bids or Bidding information) he will execute and return the Contract in accordance with the proposal as accepted and furnish the required bond(s) within **ten (10)** days from the date of mailing the Notice of Acceptance of Proposal to him at his address given below, or within such time as allowed by Valley-Wide; and that upon his failure or refusal to do so within the said time, then the certified or cashier's check or bond accompanying this bid shall become the property of and be retained by Valley-Wide as liquidated damages for such failure or refusal, and shall be deposited with the Accountant of said Valley-Wide as monies belonging to Valley-Wide; provided, that if said Bidder shall execute the Contract and furnish the required bond within the time aforesaid, his check or bond shall be returned to him thereafter.

The Bidder further declares that the surety or sureties named in the attached sheet have agreed to furnish bond in form and amount set forth in the accompanying Notice Inviting Bids (or Bidding Information) and Article 11 of the Instructions to Bidders, in the event contract is awarded on basis of this proposal.

Company: _____

Address: _____ Date: _____

By: _____
 (Print Name) Name should appear below (Signature of Owner or Officer required)

Name(s) of Member of Firm or Officer of Corporation Authorized to enter into a binding Contract:	Address (if different from above)

For further detail on this proposal, please contact:

Name:	Address:
Email Address:	Telephone:

DESIGNATION OF SUBCONTRACTORS

In compliance with the provisions of Sec. 4100-4111, inclusive, of the Public Contract Code of the State of California, and any amendments thereof, each bidder shall set forth below: (a) The name and the location of the place of business of each subcontractor who will perform work or labor or render service to the Contractor in or about the construction of the work or improvement in an amount in excess of one-half of one percent (1/2 of 1%) of the Contractor's total bid; and (b) the portion of the work which will be done by each such subcontractor.

Each subcontractor shall possess, both at the time the bid is submitted and at all times when work is performed, a valid contractor's license for the appropriate classification necessary to perform the work for which that subcontractor is listed. Each subcontractor shall be registered with the Department of Industrial Relations at time of bid and during the performance of the Contract.

If the Contractor fails to specify a subcontractor for any portion of the work to be performed under the contract in excess of one-half of one percent (1/2 of 1%) of the Contractor's total bid, he agrees that he is fully qualified to perform that work himself, and that he shall perform that work himself, and that he shall perform that portion himself.

The Contractor shall not, without the consent of the District, or unless, either: (a) Substitute any person as subcontractor in place of the subcontractor designated in the original bid; (b) Permit any such subcontract to be assigned or transferred or allow it to be performed by anyone other than the original subcontractor listed in the bid; or (c) Sublet or subcontract any portion of the work in excess of one-half of one percent (1/2 of 1%) of the Contractor's total bid as to which his original bid did not designate a subcontractor.

In the following instances, the District may consent to the substitution of another subcontractor:

(1) When the subcontractor listed in the bid after having a reasonable opportunity to do so fails or refuses to execute the written contract which is based upon the general terms, conditions, plans and specifications of the involved project or the terms of the subcontractor's written bid when it is presented to the subcontractor by the prime subcontractor;

(2) When the listed subcontractor becomes bankrupt or insolvent;

(3) When the listed subcontractor fails or refuses to perform his or her subcontract;

(4) When the listed subcontractor fails or refuses to meet the bond requirements of the prime Contractor to furnish a bond guaranteeing prompt and faithful performance of the subcontract and the payment of all claims for labor and materials furnished or used pursuant to Public Contract Code 4108;

(5) When the prime Contractor demonstrates to the District, as set forth in Public Contract Code 4107.5 that the name of the subcontractor was listed as the result of an inadvertent clerical error;

As a condition to assert claim of clerical error, the Contractor must give written notice of the inadvertent clerical error to the District with copies to both the listed and intended subcontractor within two (2) working days of the time of the prime bid opening. The District shall consent to the substitution if the prime Contractor and both subcontractor listed in error and the intended subcontractor each submit an affidavit to the District within eight (8) working days of the time of the prime bid opening indicating that an inadvertent clerical error was made.

The District shall also consent to the substitution of the intended Contractor if affidavits are filed by both the prime Contractor and the intended Subcontractor within six (6) working days and the subcontractor claimed to be listed in error does not submit within six (6) working days a written objection to the claim to both the District and the Contractor.

However, if the listed subcontractor submits a written objection to the Contractor's claim of inadvertent clerical error within six (6) working days from the time of the prime bid opening, the District shall investigate the claims of the parties and shall hold a public hearing as described herein to determine the validity of those claims.

Any declarations submitted must be submitted under penalty of perjury by all three (3) parties and supported by testimony under oath and subject to cross-examination.

(6) When the listed Contractor is not licensed pursuant to the Contractor's license law;

(7) When the District determines that the work performed by the listed subcontractor is substantially unsatisfactory and not in substantial accordance with the plans and specifications, or that the subcontractor is substantially delaying or disrupting the progress of the work.

Prior to any substitution of a subcontractor, the District shall give notice in writing to the listed subcontractor of the request to substitute subcontractors and the reasons for the request. The notice shall be served by registered or certified mail to the last known address of the subcontractor. The listed subcontractor who has been so notified shall have five (5) working days within which to submit written objections to the substitution to the District. Failure to file these written objections shall constitute the listed subcontractor's consent to the substitution. If written objections are filed, the District shall give notice in writing of at least five (5) working days to the listed subcontractor of a hearing by the District on the Contractor's request for substitution.

The original bid need not designate a subcontractor for the performance of any change orders.

No subletting or subcontracting of any portion of the work in excess of one-half of one percent (1/2 of 1%) of the prime Contractor's total bid shall be permitted except in cases of public emergency or necessity and then only after a written finding is made by the District as a public record setting forth the facts constituting the emergency or necessity.

As used in this designation, the term subcontractor means only those subcontractors who contract directly with the prime Contractor.

If the Contractor violates any of the provisions of this section, it is deemed to have violated and breached this contract, and the District may exercise the option in its own discretion of: (1) canceling the contract; or (2) assessing the contract or a penalty in an amount of not more than ten percent (10%) of the amount of the subcontract involved, and this penalty shall be deposited in the fund out of which the prime contract is awarded. The Contractor shall be entitled to a public hearing in five (5) days notice of the time and place of the hearing.

LIST OF DESIGNATED SUBCONTRACTORS

SPEC #:	
PROJECT TITLE:	
NAME OF CONTRACTOR:	

In compliance with the provisions of Sec. 4100-4111, inclusive, of the Public Contract Code of the State of California, and any amendments thereof, each bidder shall set forth: the name, location of the place of business, license number, portion of the work which will be done by each subcontractor who will perform work or labor or render service to the Contractor in or about the construction of the work or improvement in an amount in excess of one-half of one percent (1/2 of 1%) of the Contractor's total bid. Each portion of Subcontracted work noted in the below table must be specific and contain all major activities associated with completion of the project, outside of the services provided by the bidding Contractor. Ambiguous and/or incomplete Subcontracted work information may deem the bid nonresponsive. **Each subcontractor shall possess, both at the time the bid is submitted and at all times when work is performed, a valid contractor's license for the appropriate classification necessary to perform the work for which that subcontractor is listed.**

BIDDER SHALL PROVIDE THE FOLLOWING INFORMATION:

Company Name, Business Address, Email Address, License No., Contractor Registration No., Subcontract Work, and % Of Total Bid

*** PLEASE WRITE LEGIBLY***

LICENSED SUBCONTRACTOR'S NAME, BUSINESS ADDRESS, & EMAIL ADDRESS	LICENSE #	SUBCONTRACT WORK <i>(Be Specific)</i>	% OF TOTAL BID
	CONTRACTOR REGISTRATION #		
<i>Company Name:</i>	<i>License #:</i>		
<i>Address:</i>	<i>DIR Registration #:</i>		
<i>Email Address:</i>			
<i>Company Name:</i>	<i>License #:</i>		
<i>Address:</i>	<i>DIR Registration #:</i>		
<i>Email Address:</i>			

LICENSED SUBCONTRACTOR'S NAME, BUSINESS ADDRESS, & EMAIL ADDRESS	LICENSE #	SUBCONTRACT WORK <i>(Be Specific)</i>	% OF TOTAL BID
<i>Company Name:</i> <hr/> <i>Address:</i> <hr/> <i>Email Address:</i>	<i>License #:</i> <hr/> <i>DIR Registration #:</i>		
<i>Company Name:</i> <hr/> <i>Address:</i> <hr/> <i>Email Address:</i>	<i>License #:</i> <hr/> <i>DIR Registration #:</i>		
<i>Company Name:</i> <hr/> <i>Address:</i> <hr/> <i>Email Address:</i>	<i>License #:</i> <hr/> <i>DIR Registration #:</i>		
<i>Company Name:</i> <hr/> <i>Address:</i> <hr/> <i>Email Address:</i>	<i>License #:</i> <hr/> <i>DIR Registration #:</i>		
<i>Company Name:</i> <hr/> <i>Address:</i> <hr/> <i>Email Address:</i>	<i>License #:</i> <hr/> <i>DIR Registration #:</i>		

(Do not list alternative subcontractors for the same work) (Use additional pages if needed)

CONTRACTOR'S LICENSING STATEMENT

The undersigned is licensed in accordance with the laws of the State of _____ providing for the registration of contractors. The representations made herein and in the proposal documents are made under penalty of perjury. The undersigned is hereby representing that he is properly licensed both at the time that he submits a bid as well as at the time the contract is awarded, if the contract is awarded to the undersigned.

CONTRACTOR'S CLASSIFICATION _____

LICENSE NUMBER _____ TYPE _____ EXPIRATIONDATE _____

A. INDIVIDUAL CONTRACTOR

NAME OF INDIVIDUAL CONTRACTOR:
BUSINESS ADDRESS:
PHONE NUMBER:
SIGNATURE OF OWNER:

B. FIRM OR PARTNERSHIP

NAME OF FIRM OR PARTNERSHIP:
BUSINESS ADDRESS:
PHONE NUMBER:
SIGNATURE(S) & TITLE OF MEMBERS SIGNING ON BEHALF OF THE PARTNERSHIP:
SIGNATURE: _____ TITLE: _____
SIGNATURE: _____ TITLE: _____
SIGNATURE: _____ TITLE: _____

C. CORPORATION

NAME OF CORPORATION:
BUSINESS ADDRESS:
PHONE NUMBER:
SIGNATURE OF AUTHORIZED OFFICER OF CORPORATION:
SIGNATURE: _____ TITLE: _____

NON-COLLUSION DECLARATION

TO BE EXECUTED BY BIDDER AND SUBMITTED WITH BID

The undersigned declares:

I am the _____ of _____,
the party making the foregoing bid.

The bid is not made in the interest of, or on behalf of, any undisclosed person, partnership, company, association, organization, or corporation. The bid is genuine and not collusive or sham. The bidder has not directly or indirectly induced or solicited any other bidder to put in a false or sham bid. The bidder has not directly or indirectly colluded, conspired, connived, or agreed with any bidder or anyone else to put in a sham bid, or to refrain from bidding. The bidder has not in any manner, directly or indirectly, sought by agreement, communication, or conference with anyone to fix the bid price of the bidder or of any other bidder, or to fix any overhead, profit, or cost element of the bid price, or of that of any other bidder. All statements contained in the bid are true. The bidder has not, directly or indirectly, submitted his or her bid price or any breakdown thereof, or the contents thereof, or divulged information or data relative thereto, to any corporation, partnership, company, association, organization, bid depository, or to any member or agent thereof, to effectuate a collusive or sham bid, and has not paid, and will not pay, any person or entity for such purpose.

Any person executing this declaration on behalf of a bidder that is a corporation, partnership, joint venture, limited liability company, limited liability partnership, or any other entity, hereby represents that he or she has full power to execute, and does execute, this declaration on behalf of the bidder.

I declare under penalty of perjury under the laws of the State of California that the foregoing is true and correct and that this declaration is executed on _____ [date], at _____ [city], _____ [state]

Signed: _____

Name: _____
(Print Name Here)

CONTRACT

This **CONTRACT**, is made and entered into this _____ day of _____, in the year of _____, by and between Valley-Wide Recreation and Park District, sometimes hereinafter called "District," and _____, sometimes hereinafter called "Contractor."

WITNESSETH: That the parties hereto have mutually covenanted and agreed, and by these presents do covenant and agree with each other as follows:

ARTICLE 1. for and in consideration of the payments and agreements hereinafter mentioned to be made and performed by the District, the Contractor agrees with the District to perform the following work:

**DIAMOND VALLEY LAKE COMMUNITY PARK
DEDICATION WALL AND PICKLEBALL COURT IMPROVEMENTS**

as set forth in this specification for **DIAMOND VALLEY LAKE COMMUNITY PARK
DEDICATION WALL AND PICKLEBALL COURT IMPROVEMENTS**

and to perform and complete in a good and workmanlike manner all the work pertaining thereto shown on the drawings and described in the specifications hereto attached and by this reference made a part thereof, to furnish at his own proper cost and expensed all tools, equipment, labor and materials necessary.

ARTICLE II. The District will pay and the Contractor shall receive in full compensation therefor the prices named in _____

For _____ of the bidding sheet of the proposal hereto attached for furnishing all said materials and labors, furnishing and removing all plants, temporary works or structures, tools and equipment, and doing all the work contemplated and embraced in the Contract/Agreement; also for all loss and damage arising out of the nature of the work aforesaid, or from the action of the elements, or from and unforeseen difficulties which may arise or be encountered in the prosecution of the work until its acceptance by the District, and for all risks of every description connected with the work; also for all expenses incurred by or in consequence of the suspension or discontinuance of work; except such as in the said specifications are expressly stipulated to be borne by the District; and for well and faithfully completing the work and the who thereof, in the manner shown and described in the said drawings and specification and in accordance with the requirements of the Engineer under them.

ARTICLE III. The District hereby promises and agrees with the said Contractor to employ, and does hereby employ the said Contractor to provide the material and to do the work according to the terms and conditions herein contained and referred to, for the prices aforesaid, and hereby contracts to pay the same at the time, and in the manner and upon the conditions set forth in the specifications; and the said parties for themselves, their heirs, executors, administrators, successors, and assigns, do hereby agree to the full performance of the covenants herein contained.

ARTICLE IV. The Notice Inviting Bids, the Instructions to Bidders, the Proposal, Addenda, the Specifications, and the Drawings mentioned therein, all of which are hereto attached, are hereby incorporated in and made a part of this Contract/Agreement.

IN WITNESS WHEREOF: The parties hereto have caused this contract to be executed the da and year first above written:

**VALLEY-WIDE RECREATION AND
PARK DISTRICT**

Name of Contractor

By _____

Name and Title: _____

License No. _____

Date: _____

By _____

Dean Wetter, General Manager

Date: _____

**(CONTRACTOR'S SIGNATURE MUST BE
NOTARIZED AND CORPORATE
SEAL AFFIXED, IF APPLICABLE)**

Approved as to form this _____ day of _____ 20____.

Attorney for Valley-Wide Recreation and
Park District

END OF CONTRACT

PERFORMANCE BOND.

KNOW ALL PERSONS BY THESE PRESENTS:

THAT WHEREAS, the Valley-Wide Recreation and Park District, (hereinafter referred to as "District") has awarded to _____, (hereinafter referred to as the "Contractor") an agreement for the **DIAMOND VALLEY LAKE COMMUNITY PARK DEDICATION WALL AND PICKLEBALL COURT IMPROVEMENT** (hereinafter referred to as the "Project").

WHEREAS, the work to be performed by the Contractor is more particularly set forth in the Contract Documents for the Project dated _____, (hereinafter referred to as "Contract Documents"), the terms and conditions of which are expressly incorporated herein by reference; and

WHEREAS, the Contractor is required by said Contract Documents to perform the terms thereof and to furnish a bond for the faithful performance of said Contract Documents.

NOW, THEREFORE, we, _____, the undersigned Contractor and _____ as Surety, a corporation organized and duly authorized to transact business under the laws of the State of California, are held and firmly bound unto the District in the sum of _____ DOLLARS, (\$_____), said sum being not less than one hundred percent (100%) of the total amount of the Contract, for which amount well and truly to be made, we bind ourselves, our heirs, executors and administrators, successors and assigns, jointly and severally, firmly by these presents.

THE CONDITION OF THIS OBLIGATION IS SUCH, that, if the Contractor, his or its heirs, executors, administrators, successors or assigns, shall in all things stand to and abide by, and well and truly keep and perform the covenants, conditions and agreements in the Contract Documents and any alteration thereof made as therein provided, on its part, to be kept and performed at the time and in the manner therein specified, and in all respects according to their intent and meaning; and shall faithfully fulfill all obligations including the one (1) year guarantee of all materials and workmanship; and shall indemnify and save harmless the District, its officials, officers, employees, and authorized volunteers, as stipulated in said Contract Documents, then this obligation shall become null and void; otherwise it shall be and remain in full force and effect.

As a part of the obligation secured hereby and in addition to the face amount specified therefore, there shall be included costs and reasonable expenses and fees including reasonable attorney's fees, incurred by District in enforcing such obligation.

As a condition precedent to the satisfactory completion of the Contract Documents, unless otherwise provided for in the Contract Documents, the above obligation shall hold good for a period of one (1) year after the acceptance of the work by District, during which time if Contractor shall fail to make full, complete, and satisfactory repair and replacements and totally protect the District from loss or damage resulting from or caused by defective materials or faulty workmanship. The obligations of Surety hereunder shall continue so long as any obligation of Contractor remains. Nothing herein shall limit the District's rights or the Contractor or Surety's

obligations under the Contract, law or equity, including, but not limited to, California Code of Civil Procedure Section 337.15.

Whenever Contractor shall be, and is declared by the District to be, in default under the Contract Documents, the Surety shall remedy the default pursuant to the Contract Documents, or shall promptly, at the District's option:

- i. Take over and complete the Project in accordance with all terms and conditions in the Contract Documents; or
- ii. Obtain a bid or bids for completing the Project in accordance with all terms and conditions in the Contract Documents and upon determination by Surety of the lowest responsive and responsible bidder, arrange for a Contract between such bidder, the Surety and the District, and make available as work progresses sufficient funds to pay the cost of completion of the Project, less the balance of the contract price, including other costs and damages for which Surety may be liable. The term "balance of the contract price" as used in this paragraph shall mean the total amount payable to Contractor by the District under the Contract and any modification thereto, less any amount previously paid by the District to the Contractor and any other set offs pursuant to the Contract Documents.
- iii. Permit the District to complete the Project in any manner consistent with California law and make available as work progresses sufficient funds to pay the cost of completion of the Project, less the balance of the contract price, including other costs and damages for which Surety may be liable. The term "balance of the contract price" as used in this paragraph shall mean the total amount payable to Contractor by the District under the Contract and any modification thereto, less any amount previously paid by the District to the Contractor and any other set offs pursuant to the Contract Documents.

Surety expressly agrees that the District may reject any contractor or subcontractor which may be proposed by Surety in fulfillment of its obligations in the event of default by the Contractor.

Surety shall not utilize Contractor in completing the Project nor shall Surety accept a bid from Contractor for completion of the Project if the District, when declaring the Contractor in default, notifies Surety of the District's objection to Contractor's further participation in the completion of the Project.

The Surety, for value received, hereby stipulates and agrees that no change, extension of time, alteration or addition to the terms of the Contract Documents or to the Project to be performed thereunder shall in any way affect its obligations on this bond, and it does hereby waive notice of any such change, extension of time, alteration or addition to the terms of the Contract Documents or to the Project.

IN WITNESS WHEREOF, we have hereunto set our hands and seals this _____ day of _____, 20____.

(Corporate Seal)

Contractor/ Principal

By _____

Title _____

(Corporate Seal)

Surety

By _____
Attorney-in-Fact

(Attach Attorney-in-Fact Certificate)

Title _____

The rate of premium on this bond is _____ per thousand. The total amount of premium charges is \$_____.
(The above must be filled in by corporate attorney.)

THIS IS A REQUIRED FORM

Any claims under this bond may be addressed to:

(Name and Address of Surety) _____

(Name and Address of Agent or Representative for service of process in California, if different from above) _____

(Telephone number of Surety and Agent or Representative for service of process in California) _____

Notary Acknowledgment

A notary public or other officer completing this certificate verifies only the identity of the individual who signed the document, to which this certificate is attached, and not the truthfulness, accuracy, or validity of that document.

STATE OF CALIFORNIA
COUNTY OF _____

On _____, 20____, before me, _____, Notary Public, personally appeared _____, who proved to me on the basis of satisfactory

evidence to be the person(s) whose name(s) is/are subscribed to the within instrument and acknowledged to me that he/she/they executed the same in his/her/their authorized capacity(ies), and that by his/her/their signature(s) on the instrument the person(s), or the entity upon behalf of which the person(s) acted, executed the instrument.

I certify under PENALTY OF PERJURY under the laws of the State of California that the foregoing paragraph is true and correct.

WITNESS my hand and official seal.

Signature of Notary Public

OPTIONAL

Though the information below is not required by law, it may prove valuable to persons relying on the document and could prevent fraudulent removal and reattachment of this form to another document.

CAPACITY CLAIMED BY SIGNER

DESCRIPTION OF ATTACHED DOCUMENT

- Individual
- Corporate Officer

Title(s)

Title or Type of Document

- Partner(s)
 - Limited
 - General

Number of Pages

- Attorney-In-Fact
- Trustee(s)
- Guardian/Conservator
- Other:

Date of Document

Signer is representing:
Name Of Person(s) Or Entity(ies)

Signer(s) Other Than Named Above

NOTE: This acknowledgment is to be completed for the Attorney-in-Fact. The Power-of Attorney to local representatives of the bonding company must also be attached.

END OF PERFORMANCE BOND

PAYMENT BOND

KNOW ALL MEN BY THESE PRESENTS That

WHEREAS, the Valley-Wide Recreation and Park District (hereinafter designated as the "District"), by action taken or a resolution passed _____, 20____, has awarded to _____ hereinafter designated as the "Principal," a contract for the work described as follows: **DIAMOND VALLEY LAKE COMMUNITY PARK DEDICATION WALL AND PICKLEBALL COURT IMPROVEMENTS**

WHEREAS, said Principal is required to furnish a bond in connection with said contract; providing that if said Principal or any of its Subcontractors shall fail to pay for any materials, provisions, provender, equipment, or other supplies used in, upon, for or about the performance of the work contracted to be done, or for any work or labor done thereon of any kind, or for amounts due under the Unemployment Insurance Code or for any amounts required to be deducted, withheld, and paid over to the Employment Development Department from the wages of employees of said Principal and its Subcontractors with respect to such work or labor the Surety on this bond will pay for the same to the extent hereinafter set forth.

NOW THEREFORE, we, the Principal and _____ as Surety, are held and firmly bound unto the District in the penal sum of _____ Dollars (\$_____) lawful money of the United States of America, for the payment of which sum well and truly to be made, we bind ourselves, our heirs, executors, administrators, successors and assigns, jointly and severally, firmly by these presents.

THE CONDITION OF THIS OBLIGATION IS SUCH that if said Principal, his or its subcontractors, heirs, executors, administrators, successors or assigns, shall fail to pay any of the persons named in Civil Code Section 9100, fail to pay for any materials, provisions or other supplies, used in, upon, for or about the performance of the work contracted to be done, or for any work or labor thereon of any kind, or amounts due under the Unemployment Insurance Code with respect to work or labor performed under the contract, or for any amounts required to be deducted, withheld, and paid over to the Employment Development Department or Franchise Tax Board from the wages of employees of the contractor and his subcontractors pursuant to Revenue and Taxation Code Section 18663, with respect to such work and labor the Surety or Sureties will pay for the same, in an amount not exceeding the sum herein above specified, and also, in case suit is brought upon this bond, all litigation expenses incurred by the District in such suit, including reasonable attorneys' fees, court costs, expert witness fees and investigation expenses.

This bond shall inure to the benefit of any of the persons named in Civil Code Section 9100 so as to give a right of action to such persons or their assigns in any suit brought upon this bond.

It is further stipulated and agreed that the Surety on this bond shall not be exonerated or released from the obligation of this bond by any change, extension of time for performance, addition, alteration or modification in, to, or of any contract, plans, specifications, or agreement pertaining or relating to any scheme or work of improvement herein above described, or pertaining or relating to the furnishing of labor, materials, or equipment therefore, nor by any change or modification of any terms of payment or extension of the time for any payment pertaining or relating to any scheme or work of improvement herein above described, nor by any rescission or attempted rescission or attempted rescission of the contract, agreement or bond, nor by any conditions precedent or subsequent in the bond attempting to limit the right of

recovery of claimants otherwise entitled to recover under any such contract or agreement or under the bond, nor by any fraud practiced by any person other than the claimant seeking to recover on the bond and that this bond be construed most strongly against the Surety and in favor of all persons for whose benefit such bond is given, and under no circumstances shall Surety be released from liability to those for whose benefit such bond has been given, by reason of any breach of contract between the owner or District and original contractor or on the part of any obligee named in such bond, but the sole conditions of recovery shall be that claimant is a person described in Civil Code Section 9100, and has not been paid the full amount of his claim and that Surety does hereby waive notice of any such change, extension of time, addition, alteration or modification herein mentioned, including but not limited to the provisions of sections 2819 and 2845 of the California Civil Code.

IN WITNESS WHEREOF, we have hereunto set our hands and seals this _____ day of _____, 20__.

(Corporate Seal)

Contractor/ Principal

By _____

Title _____

(Corporate Seal)

Surety

By _____
Attorney-in-Fact

(Attach Attorney-in-Fact Certificate)

Title _____

Notary Acknowledgment

A notary public or other officer completing this certificate verifies only the identity of the individual who signed the document, to which this certificate is attached, and not the truthfulness, accuracy, or validity of that document.

STATE OF CALIFORNIA
 COUNTY OF _____

On _____, 20____, before me, _____, Notary Public, personally appeared _____, who proved to me on the basis of satisfactory

evidence to be the person(s) whose name(s) is/are subscribed to the within instrument and acknowledged to me that he/she/they executed the same in his/her/their authorized capacity(ies), and that by his/her/their signature(s) on the instrument the person(s), or the entity upon behalf of which the person(s) acted, executed the instrument.

I certify under PENALTY OF PERJURY under the laws of the State of California that the foregoing paragraph is true and correct.

WITNESS my hand and official seal.

Signature of Notary Public _____

OPTIONAL

Though the information below is not required by law, it may prove valuable to persons relying on the document and could prevent fraudulent removal and reattachment of this form to another document.

CAPACITY CLAIMED BY SIGNER

DESCRIPTION OF ATTACHED DOCUMENT

- Individual
- Corporate Officer

_____ Title(s)

_____ Title or Type of Document

- Partner(s) Limited
- General

_____ Number of Pages

- Attorney-In-Fact
- Trustee(s)
- Guardian/Conservator
- Other:

_____ Date of Document

Signer is representing:
 Name Of Person(s) Or Entity(ies)

_____ Signer(s) Other Than Named Above

NOTE: This acknowledgment is to be completed for Contractor/Principal.

Notary Acknowledgment

A notary public or other officer completing this certificate verifies only the identity of the individual who signed the document, to which this certificate is attached, and not the truthfulness, accuracy, or validity of that document.

STATE OF CALIFORNIA
 COUNTY OF _____

On _____, 20____, before me, _____, Notary Public, personally appeared _____, who proved to me on the basis of satisfactory

evidence to be the person(s) whose name(s) is/are subscribed to the within instrument and acknowledged to me that he/she/they executed the same in his/her/their authorized capacity(ies), and that by his/her/their signature(s) on the instrument the person(s), or the entity upon behalf of which the person(s) acted, executed the instrument.

I certify under PENALTY OF PERJURY under the laws of the State of California that the foregoing paragraph is true and correct.

WITNESS my hand and official seal.

Signature of Notary Public _____

OPTIONAL

Though the information below is not required by law, it may prove valuable to persons relying on the document and could prevent fraudulent removal and reattachment of this form to another document.

CAPACITY CLAIMED BY SIGNER

DESCRIPTION OF ATTACHED DOCUMENT

- Individual
- Corporate Officer

_____ Title(s)

_____ Title or Type of Document

- Partner(s) Limited
- Attorney-In-Fact General

_____ Number of Pages

- Trustee(s)
- Guardian/Conservator
- Other:

_____ Date of Document

Signer is representing:
 Name Of Person(s) Or Entity(ies)

_____ Signer(s) Other Than Named Above

NOTE: This acknowledgment is to be completed for the Attorney-in-Fact. The Power-of-Attorney to local representatives of the bonding company must also be attached.

END OF PAYMENT BOND

Project Title: _____

WORKERS' COMPENSATION INSURANCE CERTIFICATE

The Contractor shall execute the following form as required by the California Labor Code, Sections 1860 and 1861:

I am aware of the provisions of Section 3700 of the Labor Code which require every employer to be insured against liability for workers' compensation or to undertake self-insurance in accordance with the provisions of that code, and I will comply with such provisions before commencing the performance of the work of this contract. Date: _____
(Contractor) By: _____ (Signature) _____ (Title)

Date: _____

(Contractor)

By: _____
(Signature)

(Title)

 **VALLEY-WIDE RECREATION
AND PARK DISTRICT**
GoRecreation.org
AWARD WINNING CALIFORNIA PARKS
MEMORANDUM

901 W. Esplanade Ave.
(951) 654-1505
P.O. Box 907
San Jacinto, CA 92581

TO: Whom It May Concern

FROM: Valley-Wide Recreation and Park District

SUBJECT: Insurance

Insurance: Each group needs to provide Valley-Wide Recreation and Park District with a Certificate of Insurance naming **Valley-Wide Recreation and Park District** as Additional Insured, (\$1,000,000 General Liability Limit/\$2,000,000 General Aggregate). Also must include **Form Number CG20 10, Additional Endorsement** with Valley-Wide Recreation and Park District listed as Additional Insured. (Or provide the Additional Insured Endorsement form used by the Insurance Carrier.)

ALSO: Please have the statement: **“Throughout Various Valley-Wide Recreation Facilities”** added to the Description of Operations Box on the certificate of Insurance. (This is to cover the use of any facility sites being used)

Note: Any one utilizing the facility and having alcohol present, must also include Liquor Liability Coverage on the Certificate of Insurance.

Certificate Holder and Additional Endorsement forms should read:

Valley-Wide Recreation & Park District
901 W. Esplanade Ave.
P.O. Box 907
San Jacinto, Ca 92582

Please Note: When submitting the Certificate and Additional Endorsement forms to Valley-Wide Recreation, please include the following information on a front cover page or envelope. This will ensure that the forms will be directed to the correct Valley-Wide Recreation site.

Facility SITE: Regional ATTENTION: James Salvador

Facility Number (for any questions): (951) 654-1505

Facility FAX Number: (951) 654-5279

Contact EMAIL: JamesS@GoRecreation.org

IRAN CONTRACTING ACT
(Public Contract Code sections 2202-2208)

Prior to bidding on, submitting a proposal or executing a contract or renewal for a State of California contract for goods or services of \$1,000,000 or more, a vendor must either: a) certify it is **not** on the current list of persons engaged in investment activities in Iran created by the California Department of General Services (“DGS”) pursuant to Public Contract Code section 2203(b) and is not a financial institution extending twenty million dollars (\$20,000,000) or more in credit to another person, for 45 days or more, if that other person will use the credit to provide goods or services in the energy sector in Iran and is identified on the current list of persons engaged in investment activities in Iran created by DGS; or b) demonstrate it has been exempted from the certification requirement for that solicitation or contract pursuant to Public Contract Code section 2203(c) or (d).

To comply with this requirement, please insert your vendor or financial institution name and Federal ID Number (if available) and complete **one** of the options below. Please note: California law establishes penalties for providing false certifications, including civil penalties equal to the greater of \$250,000 or twice the amount of the contract for which the false certification was made; contract termination; and three-year ineligibility to bid on contracts. (Public Contract Code section 2205.)

OPTION #1 - CERTIFICATION

I, the official named below, certify I am duly authorized to execute this certification on behalf of the vendor/financial institution identified below, and the vendor/financial institution identified below is **not** on the current list of persons engaged in investment activities in Iran created by DGS and is not a financial institution extending twenty million dollars (\$20,000,000) or more in credit to another person/vendor, for 45 days or more, if that other person/vendor will use the credit to provide goods or services in the energy sector in Iran and is identified on the current list of persons engaged in investment activities in Iran created by DGS.

<i>Vendor Name/Financial Institution (Printed)</i>	<i>Federal ID Number (or n/a)</i>
<i>By (Authorized Signature)</i>	
<i>Printed Name and Title of Person Signing</i>	
<i>Date Executed</i>	<i>Executed in</i>

OPTION #2 – EXEMPTION

Pursuant to Public Contract Code sections 2203(c) and (d), a public entity may permit a vendor/financial institution engaged in investment activities in Iran, on a case-by-case basis, to be eligible for, or to bid on, submit a proposal for, or enters into or renews, a contract for goods and services.

If you have obtained an exemption from the certification requirement under the Iran Contracting Act, please fill out the information below, and attach documentation demonstrating the exemption approval.

<i>Vendor Name/Financial Institution (Printed)</i>	<i>Federal ID Number (or n/a)</i>
<i>By (Authorized Signature)</i>	
<i>Printed Name and Title of Person Signing</i>	<i>Date Executed</i>

Cal/OSHA Form 300A

Annual Summary of Work-Related Injuries and Illnesses

**Bidders shall provide the most current, completed
Cal/OSHA Form 300A with their bid (blank form attached)**

Failure to submit this form "may" deem your bid non-responsive

Annual Summary of Work-Related Injuries and Illnesses

All establishments covered by CCR Title 8 Section 14300 must complete this Annual Summary, even if no work-related injuries or illnesses occurred during the year. Remember to review the Log to verify that the entries are complete and accurate before completing this summary.

Using the Log, count the individual entries you made for each category. Then write the totals below, making sure you've added the entries from every page of the Log. If you had no cases, write "0."

Employees, former employees, and their representatives have the right to review the Cal/OSHA Form 300 in its entirety. They also have limited access to the Cal/OSHA Form 301 or its equivalent. See CCR Title 8 Section 14300.35, in Cal/OSHA's recordkeeping rule, for further details on the access provisions for these forms.

Number of Cases

Total number of deaths	Total number of cases with days away from work	Total number of cases with job transfer or restriction	Total number of other recordable cases
_____	_____	_____	_____
(G)	(H)	(I)	(J)

Number of Days

Total number of days away from work	Total number of days of job transfer or restriction
_____	_____
(K)	(L)

Injury and Illness Types

Total number of . . .			
(M)			
(1) Injuries	_____	(4) Poisonings	_____
(2) Skin disorders	_____	(5) Hearing loss	_____
(3) Respiratory conditions	_____	(6) All other Illnesses	_____

Establishment information

Your establishment name _____

Street _____

City _____ State _____ ZIP _____

Industry description (e.g., *Manufacture of motor truck trailers*)

Standard Industrial Classification (SIC), if known (e.g., *SIC 3715*)

Employment information (If you don't have these figures, use the optional Worksheet to estimate.)

Annual average number of employees _____

Total hours worked by all employees last year _____

Sign here

Knowingly falsifying this document may result in a fine.

I certify that I have examined this document and that to the best of my knowledge the entries are true, accurate, and complete.

Company executive _____ Title _____

Phone _____ Date _____

C-17 Contractor's Cal/OSHA Compliance History and SIC Code
THIS DOCUMENT IS TO BE SUBMITTED WITH THE PROPOSAL PACKAGE AT TIME OF BID

Bidders shall complete and submit the attached C-17 form with the Proposal Package at time of bid

Failure to fully divulge, complete and submit this form "may" deem your bid non-responsive

C-17 Contractor's Cal/OSHA Compliance History and SIC Code
THIS DOCUMENT IS TO BE SUBMITTED WITH THE PROPOSAL PACKAGE AT TIME OF BID

Bid Date:		Contractor's Standard Industry Code:	
Specification No.		Project Name:	
Contractor name:			
Contractor Address:			
Contractor License No.		Phone No:	
Contact Person:			

Please answer the following questions:

- 1. Has the Contractor been cited by Cal/OSHA or any regulatory agency for a violation related to safety or environmental issues within the past seven (7) years?** No Yes

If yes, please attach all documentation specific to each violation and what actions have been taken to ensure that there is not a repeat violation.

- 2. Has the Contractor had a fatality or serious incident per Cal/OSHA on a jobsite within the past ten (10) years?** No Yes

If yes, please attach all documentation specific to each violation and what actions have been taken to ensure that there is not a repeat violation.

I certify (or declare) under penalty of perjury under the laws of the State of California that the foregoing is true and correct.

Contractor's Representative signature:		Date:	
---	--	--------------	--

Failure to fully divulge, complete and submit this form "may" deem your bid non-responsive

FOR EMWD USE ONLY: Field Engineering to forward to Risk Management for review

Approved:	No <input type="checkbox"/>	Yes <input type="checkbox"/>
Reviewed by Risk Management (signature required)		Date:
Return to (Field Eng.CAR)		By:

cc: Construction Administrator
 File: C-17 Contractor's Compliance History

Public Works Contractor Registration Certification

Pursuant to Labor Code sections 1725.5 and 1771.1

All contractors and subcontractors that wish to bid on, be listed in a bid proposal, or enter into a contract to perform public work must be registered with the Department of Industrial Relations. See <http://www.dir.ca.gov/Public-Works/PublicWorks.html> for additional information.

No bid will be accepted nor any contract entered into without proof of the contractor's and subcontractors' current registration with the Department of Industrial Relations to perform public work.

Bidder hereby certifies that it is aware of the registration requirements set forth in Labor Code sections 1725.5 and 1771.1 and is currently registered as a contractor with the Department of Industrial Relations.

Name of Bidder: _____

DIR Registration Number: _____

DIR Registration Expiration: _____

Bidder further acknowledges:

1. Bidder shall maintain a current DIR registration for the duration of the project.
2. Bidder shall include the requirements of Labor Code sections 1725.5 and 1771.1 in its contract with subcontractors and ensure that all subcontractors are registered at the time of bid opening and maintain registration status for the duration of the project.
3. Failure to submit this form or comply with any of the above requirements may result in a finding that the bid is non-responsive.

Name of Bidder _____

Signature _____

Name and Title _____

Dated _____

GENERAL CONDITIONS
Section F – Labor & Construction
Table of Contents

ARTICLE 1 - DEFINITIONS.....	F1
ARTICLE 2 - CONTRACT DOCUMENTS.....	F5
ARTICLE 3 - PRECONSTRUCTION AND CONSTRUCTION COMMUNICATION.....	F6
ARTICLE 4 - CONTRACT DOCUMENTS: COPIES & MAINTENANCE	F6
ARTICLE 5 - EXAMINATION OF DRAWINGS, SPECIFICATION & SITE WORK.....	F6
ARTICLE 6 - MOBILIZATION	F7
ARTICLE 7 - EXISTENCE OF UTILITIES AT THE WORK SITE	F8
ARTICLE 8 - SOILS INVESTIGATIONS	F9
ARTICLE 9 - CONTRACT SUPERVISION.....	F9
ARTICLE 10 - WORKERS.....	F9
ARTICLE 11 - INDEPENDENT CONTRACTORS	F10
ARTICLE 12 - SUBCONTRACTS	F10
ARTICLE 13 - VERIFICATIONS OF EMPLOYMENT ELIGIBILITY.....	F10
ARTICLE 14 - REQUEST FOR SUBSTITUTION	F10
ARTICLE 15 - SHOP DRAWINGS	F12
ARTICLE 16 - SUBMITTALS.....	F12
ARTICLE 17 - MATERIALS.....	F13
ARTICLE 18 - PERMITS AND LICENSES.....	F13
ARTICLE 19 - TRENCHES	F14
ARTICLE 20 - TRAFFIC CONTROL	F15
ARTICLE 21 - DIVERSION OF RECYCLEABLE WASTE MATERIALS	F16
ARTICLE 22 - REMOVAL OF HAZARDOUS MATERIALS	F16
ARTICLE 23 - SANITARY FACILITIES	F16
ARTICLE 24 - AIR POLLUTION CONTROL.....	F16
ARTICLE 25 - LAYOUT AND FIELD ENGINEERING.....	F16
ARTICLE 26 - TESTS AND INSPECTIONS.....	F17
ARTICLE 27 - PROTECTION OF WORK AND PROPERTY.....	F17
ARTICLE 28 - CONTRACTORS MEANS AND METHODS	F18
ARTICLE 29 - AUTHORIZED REPRESENTATIVES	F18
ARTICLE 30 - HOURS OF WORK.....	F18
ARTICLE 31 - PAYROLL RECORDS	F19
ARTICLE 32 - PREVAILING RATES OF WAGES	F20
ARTICLE 33 - PUBLIC WORKS CONTRACTOR REGISTRATION.....	F21
ARTICLE 34 - EMPLOYMENT OF APPRENTICES	F21
ARTICLE 35 - NONDISCRIMINATION EQUAL EMPLOYMENT OPPORTUNITY	F22
ARTICLE 36 - DEBARMENT OF CONTRACTORS AND SUBCONTRACTORS.....	F22
ARTICLE 37 - LABOR EMPLOYMENT SAFETY	F23
ARTICLE 38 - INSURANCE.....	F23
ARTICLE 39 - FORM AND PROOF OF CARRIAGE OF INSURANCE	F27
ARTICLE 40 - TIME FOR COMPLETION AND LIQUIDATED DAMAGES.....	F28

GENERAL CONDITIONS
Section F – Labor & Construction
Table of Contents

ARTICLE 41 - COST BREAKDOWN AND INVOICING	F29
ARTICLE 42 - PROGRESS ESTIMATES AND PAYMENTS	F29
ARTICLE 43 - SECURITIES FOR MONEY WITHHELD.....	F31
ARTICLE 44 - CHANGES AND EXTRA WORK	F31
ARTICLE 45 - FINAL ACCEPTANCE AND PAYMENT	F43
ARTICLE 46 - OCCUPANCY.....	F44
ARTICLE 47 - INDEMINIFICATION	F45
ARTICLE 48 - PROCEDURE FOR RESOLVING DISPUTES.....	F46
ARTICLE 49 - DISTRICT’S RIGHT TO TERMINATE CONTRACT	F47
ARTICLE 50 - WARRANTY AND GUARANTEE OF WORK	F50
ARTICLE 51 - DOCUMENT RETENTION & EXAMINATION	F53
ARTICLE 52 - SEPARATE CONTRACTS	F53
ARTICLE 53 - NOTICE AND SERVICE THEREOF.....	F54
ARTICLE 54 - NOTICE OF THIRD PARTY CLAIMS	F54
ARTICLE 55 - STATE LICENSE BOARD NOTICE.....	F54
ARTICLE 56 - INTEGRATION	F54
ARTICLE 67 - ASSIGNMENT OF CONTRACT.....	F54
ARTICLE 58 - CHANGE IN NAME AND NATURE OF CONTRACTOR’S LEGAL ENTITY	F55
ARTICLE 59 - ASSISNGMENT OF ANTITRUST ACTIONS	F55
ARTICLE 60 - PROHIBITED INTERESTS	F55
ARTICLE 61 - CONTROLLING LAW.....	F55
ARTICLE 62 - JURISDICTION; VENUE	F55
ARTICLE 63 - LAWS AND REGULATIONS	F55
ARTICLE 64 - PATENTS	F56
ARTICLE 65 - OWNERSHIP OF CONTRACT DOCUMENTS.....	F56
ARTICLE 66 - NOTICE OF TAXABLE POSSESSORY	F56
ARTICLE 67 - SURVIVAL OF OBLIGATIONS.....	F56

GENERAL CONDITIONS
SECTION F- LABOR AND CONSTRUCTION

ARTICLE 1 DEFINITIONS

Whenever used in the Contract Documents and printed with initial capital letters, the terms listed below will have the meanings indicated which are applicable to both the singular and plural thereof. In addition to terms specifically defined below, terms with initial capital letters in the Contract Documents include references to identified articles and paragraphs, and the titles of other documents or forms.

- A. Act of God – An earthquake of magnitude of 3.5 or higher on the Richter scale or a tidal wave.
- B. Addenda -- Written or graphic instruments issued prior to the submission of Bids which clarify, correct, or change the Contract Documents.
- C. Additional Work -- New or unforeseen work will be classified as “Additional Work” when the District’s Representative determines that it is not covered by the Contract.
- D. Applicable Laws -- The laws, statutes, ordinances, rules, codes, regulations, permits, and licenses of any kind, issued by local, state or federal governmental authorities or private authorities with jurisdiction (including utilities), to the extent they apply to the Work.
- E. Bid -- The offer or proposal of a Bidder submitted on the prescribed form setting forth the prices and other terms for the Work to be performed.
- F. Bidder -- The individual or entity who submits a Bid directly to the District.
- G. Change Order (“CO”) -- A document that authorizes an addition, deletion, or revision in the Work or an adjustment in the Contract Price or the Contract Times, issued on or after the Effective Date of the Contract, in accordance with the Contract Documents and in the form contained in the Contract Documents.
- H. Change Order Request (“COR”) -- A request made by the Contractor for an adjustment in the Contract Price and/or Contract Times as the result of a Contractor-claimed change to the Work. This term may also be referred to as a Change Order Proposal (“COP”), or Request for Change (“RFC”).
- I. District -- The Valley-Wide Recreation and Park District.
- J. District Board, Board -- The Board of Directors of the District.
- K. District’s Representative -- The individual or entity as identified in the Special Conditions to act as the District’s Representative.
- L. Claim -- A demand or assertion by the District or Contractor seeking an adjustment of Contract Price or Contract Times, or both, or other relief with respect to the terms of the Contract. A demand for money or services by a third party is not a Claim.
- M. Contract -- The entire integrated written agreement between the District and Contractor concerning the Work. “Contract” may be used interchangeably with

GENERAL CONDITIONS
SECTION F- LABOR AND CONSTRUCTION

“Agreement” in the Contract Documents. The Contract supersedes prior negotiations, representations, or agreements, whether written or oral, and includes all Contract Documents.

- N. Contract Documents -- The documents listed in Section 00 52 13, Article 5. Some documents provided by the District to the Bidders and Contractor, including but not limited to reports and drawings of subsurface and physical conditions are not Contract Documents.
- O. Contract Price -- Amount to be paid by the District to the Contractor as full compensation for the performance of the Contract and completion of the Work, subject to any additions or deductions as provided in the Contract Documents, and including all applicable taxes and costs.
- P. Contract Times -- The number of days or the dates stated in the Contract Documents to: achieve defined Milestones, if any; and to complete the Work so that it is ready for final payment.
- Q. Contractor -- The individual or entity with which the District has contracted for performance of the Work.
- R. Contractor’s Designated On-Site Representative -- The Contractor’s Designated On-Site Representative will be as identified in Section 00 72 13, Article 3 and shall not be changed without prior written consent of the District.
- S. Daily Rate -- The Daily Rate stipulated in the Contract Documents as full compensation to the Contractor due to the District’s unreasonable delay to the Project that was not contemplated by the parties.
- T. Day -- A calendar day of 24 hours measured from midnight to the next midnight.
- U. Defective Work -- Work that is unsatisfactory, faulty, or deficient; or that does not conform to the Contract Documents; or that does not meet the requirements of any inspection, reference standard, test, or approval referenced in the Contract Documents.
- V. Demobilization -- The complete dismantling and removal by the Contractor of all of the Contractor’s temporary facilities, equipment, and personnel at the Site.
- W. Drawings -- That part of the Contract Documents prepared by of the Engineer of Record which graphically shows the scope, extent, and character of the Work to be performed by Contractor. Shop Drawings and other Contractor submittals are not Drawings as so defined.
- X. Effective Date of the Contract -- The date indicated in the Contract on which it becomes effective, but if no such date is indicated, it means the date on which the Contract is signed and delivered by the last of the two parties to sign and deliver.
- Y. Engineer, whenever not qualified, shall mean the General Manager of the District, acting either directly or through properly authorized agents, such agents acting

GENERAL CONDITIONS
SECTION F- LABOR AND CONSTRUCTION

severally within the scope of the particular duties entrusted to them. On all questions concerning the acceptance of materials, machinery, the classifications of material, the execution of work, conflicting interest of the contractors performing related work and the determination of costs, the decision of the Engineer, duly authorized by the District Board, shall be binding and final upon both parties.

Z. Engineer of Record -- The individual, partnership, corporation, joint venture, or other legal entity named as such in Section 00 73 13, Article 1.1. or any succeeding entity designated by the District.

AA. Green Book -- The current edition of the Standard Specifications for Public Works Construction promulgated by the Joint Cooperative Committee of the Southern California Chapter American Public Works Association and the Southern California Districts of the Associated General Contractors of California.

BB. Hazardous Waste -- The term "Hazardous Waste" shall have the meaning provided in Section 104 of the Solid Waste Disposal Act (42 U.S.C. § 6903) as amended from time to time or, as defined in Section 25117 of the Health and Safety Code, that is required to be removed to a class I, class II, or class III disposal site in accordance with provisions of existing law, whichever is more restrictive.

CC. Holiday – The Holidays occur on:

New Year's Day - January 1
President's Day – Third Monday in February
Memorial Day - Last Monday in May
Independence Day - July 4
Labor Day - First Monday in September
Veteran's Day - November 11
Thanksgiving Day - Fourth Thursday in November
Friday after Thanksgiving
Christmas Eve – December 24
Christmas Day - December 25
Day After Christmas – December 26
New Year's Eve – December 31

If any Holiday listed above falls on a Saturday, Saturday and the preceding Friday are both Holidays. If the Holiday should fall on a Sunday, Sunday and the following Monday are both Holidays.

DD. Notice of Award -- The written notice by the District to the Successful Bidder stating that upon timely compliance by the Successful Bidder with the conditions precedent listed therein, the District will sign and deliver the Contract.

EE. Notice of Completion -- The form which may be executed by the District and recorded by the county where the Project is located constituting final acceptance of the Project.

GENERAL CONDITIONS
SECTION F- LABOR AND CONSTRUCTION

- FF. Notice to Proceed -- A written notice given by the District to Contractor fixing the date on which the Contractor may proceed with the Work and when Contract Times will commence to run.
- GG. Project -- The total construction of which the Work to be performed under the Contract Documents may be the whole, or a part.
- HH. Recyclable Waste Materials -- Materials removed from the Site which are required to be diverted to a recycling center rather than an area landfill. Recyclable Waste Materials include asphalt, concrete, brick, concrete block, and rock.
- II. Schedule of Submittals -- A schedule, prepared and maintained by Contractor, of required submittals and the time requirements to facilitate scheduled performance of related construction activities.
- JJ. Shop Drawings -- All drawings, diagrams, illustrations, schedules, and other data or information which are specifically prepared or assembled by or for Contractor and submitted by Contractor to illustrate some portion of the Work.
- KK. Specifications -- That part of the Contract Documents consisting of written requirements for materials, equipment, systems, standards and workmanship as applied to the Work, and certain administrative requirements and procedural matters applicable thereto.
- LL. Stop Payment Notice -- A written notice as defined in Civil Code section 8044.
- MM. Subcontractor -- An individual or entity other than a Contractor having a contract with any other entity than the District for performance of any portion of the Work at the Site.
- NN. Submittal -- Written and graphic information and physical samples prepared and supplied by the Contractor demonstrating various portions of the Work.
- OO. Successful Bidder -- The Bidder submitting a responsive Bid to whom the District makes an award.
- PP. Supplier -- A manufacturer, fabricator, supplier, distributor, material man, or vendor having a direct contract with Contractor or with any Subcontractor to furnish materials or equipment used in the performance of the Work or to be incorporated in the Work.
- QQ. Underground Facilities -- All underground pipelines, conduits, ducts, cables, wires, manholes, vaults, tanks, tunnels, or other such facilities or attachments, and any encasements containing such facilities, including those that convey electricity, gases, steam, liquid petroleum products, telephone or other communications, cable television, water, wastewater, storm water, other liquids or chemicals, or traffic or other control systems.

GENERAL CONDITIONS
SECTION F- LABOR AND CONSTRUCTION

- RR. Unit Price Work -- Work to be paid for on the basis of unit prices as provided by the Contractor in its bid or as adjusted in accordance with the Contract Documents.
- SS. Warranty -- A written guarantee provided to the District by the Contractor that the Work will remain free of defects and suitable for its intended use for the period required by the Contract Documents or the longest period permitted by the law of this State, whichever is longer.
- TT. Work -- The entire construction or the various separately identifiable parts thereof required to be provided under the Contract Documents. Work includes and is the result of performing or providing all labor, services, and documentation necessary to produce such construction, and furnishing, installing, and incorporating all materials and equipment into such construction, all as required by the Contract Documents.

ARTICLE 2 CONTRACT DOCUMENTS

- A. **Contract Documents.** The Contract Documents are complementary, and what is called for by one shall be as binding as if called for by all.
- B. **Interpretations.** The Contract Documents are intended to be fully cooperative and complementary. If the Contractor observes that any documents are in conflict, the Contractor shall promptly notify the Engineer in writing. In case of conflicts between the Contract Documents, the order of precedence shall be as follows:

Change Orders

1. Addenda
2. Special Conditions
3. Technical Specifications
4. Plans (Contract Drawings)
5. Contract
6. General Conditions
7. Instructions to Bidders
8. Notice Inviting Bids
9. Contractor's Bid Forms
10. Standard Specifications for Public Works Construction (Sections 1-9 Excluded)
11. Applicable Local Agency Standards and Specifications
12. Standard Drawings
13. Reference Documents

With reference to the Drawings, the order of precedence shall be as follows:

1. Figures govern over scaled dimensions
2. Detail drawings govern over general drawings
3. Addenda or Change Order drawings govern over Contract Drawings
4. Contract Drawings govern over Standard Drawings
5. Contract Drawings govern over Shop Drawings

GENERAL CONDITIONS
SECTION F- LABOR AND CONSTRUCTION

- C. **Conflicts in Contract Documents.** Notwithstanding the orders of precedence established above, in the event of conflicts, the higher standard, higher quality, and most expensive shall always apply.
- D. **Organization of Contract Documents.** Organization of the Contract Documents into divisions, sections, and articles, and arrangement of drawings shall not control the Contractor in dividing Project Work among subcontractors or in establishing the extent of Work to be performed by any trade.

ARTICLE 3 PRECONSTRUCTION AND CONSTRUCTION COMMUNICATION

Before any Work at the site is started, a conference attended by the District, Contractor, District's Representative, and others as appropriate will be held to establish a working understanding among the parties as to the Work and to discuss the schedules referred to herein, procedures for handling Shop Drawings and other submittals, processing Applications for Payment, and maintaining required records.

At this conference the District and Contractor each shall designate, in writing, a specific individual to act as its authorized representative with respect to the services and responsibilities under the Contract. Such individuals shall have the authority to transmit instructions, receive information, render decisions relative to the Contract, and otherwise act on behalf of each respective party.

ARTICLE 4 CONTRACT DOCUMENTS: COPIES & MAINTENANCE

Contractor will be furnished, free of charge, **five (5)** copies of the Contract Documents. Additional copies may be obtained at cost of reproduction.

Contractor shall maintain a clean, undamaged set of Contract Documents, including submittals, at the Project site.

ARTICLE 5 EXAMINATION OF DRAWINGS, SPECIFICATIONS AND SITE OF WORK

- A. **Examination of Contract Documents.** Before commencing any portion of the Work, Contractor shall again carefully examine all applicable Contract Documents, the Project site, and other information given to Contractor as to materials and methods of construction and other Project requirements. Contractor shall immediately notify the Engineer of any potential error, inconsistency, ambiguity, conflict, or lack of detail or explanation. If Contractor performs, permits, or causes the performance of any Work which is in error, inconsistent or ambiguous, or not sufficiently detailed or explained, Contractor shall bear any and all resulting costs, including, without limitation, the cost of correction. In no case shall the Contractor or any subcontractor proceed with Work if uncertain as to the applicable requirements.
- B. **Additional Instructions.** After notification of any error, inconsistency, ambiguity, conflict, or lack of detail or explanation, the Engineer will provide any required additional instructions, by means of drawings or other written direction, necessary for proper execution of Work.

GENERAL CONDITIONS
SECTION F- LABOR AND CONSTRUCTION

- C. **Quality of Parts, Construction and Finish.** All parts of the Work shall be of the best quality of their respective kinds and the Contractor must use all diligence to inform itself fully as to the required construction and finish.
- D. **Contractor's Variation from Contract Document Requirements.** If it is found that the Contractor has varied from the requirements of the Contract Documents including the requirement to comply with all applicable laws, ordinances, rules and regulations, the Engineer may at any time, before or after completion of the Work, order the improper Work removed, remade or replaced by the Contractor at the Contractor's expense.

ARTICLE 6 MOBILIZATION

- A. When a bid item is included in the Bid Form for mobilization, the costs of Work in advance of construction operations and not directly attributable to any specific bid item will be included in the progress estimate ("Initial Mobilization"). When no bid item is provided for "Initial Mobilization," payment for such costs will be deemed to be included in the other items of the Work.
- B. Payment for Initial Mobilization based on the lump sum provided in the Bid Form, which shall constitute full compensation for all such Work. No payment for Initial Mobilization will be made until all of the listed items have been completed to the satisfaction of the Engineer. The scope of the Work included under Initial Mobilization shall include, but shall not be limited to, the following principal items:
 - 1. Obtaining and paying for all bonds, insurance, and permits.
 - 2. Moving on to the Project site of all Contractor's plant and equipment required for the first month's operations.
 - 3. Installing temporary construction power, wiring, and lighting facilities, as applicable.
 - 4. Establishing fire protection system, as applicable.
 - 5. Developing and installing a construction water supply, if applicable.
 - 6. Providing and maintaining the field office trailers for the Contractor, if necessary, and the Engineer (if specified), complete, with all specified furnishings and utility services.
 - 7. Providing on-site sanitary facilities and potable water facilities as specified per Cal-OSHA and these Contract Documents.
 - 8. Furnishing, installing, and maintaining all storage buildings or sheds required for temporary storage of products, equipment, or materials that have not yet been installed in the Work. All such storage shall meet manufacturer's specified storage requirements, and the specific provisions of the specifications, including temperature and humidity control, if recommended by the manufacturer, and for all security.

GENERAL CONDITIONS
SECTION F- LABOR AND CONSTRUCTION

9. Arranging for and erection of Contractor's work and storage yard.
10. Posting all OSHA required notices and establishment of safety programs per Cal-OSHA.
11. Full-time presence of Contractor's superintendent at the job site as required herein.
12. Submittal of Construction Schedule as required by the Contract Documents.

ARTICLE 7 EXISTENCE OF UTILITIES AT THE WORK SITE

- A. The District has endeavored to determine the existence of utilities at the Project site from the records of the owners of known utilities in the vicinity of the Project. The positions of these utilities as derived from such records are shown on the Plans.
- B. Unless indicated otherwise on the Plans and Specifications, no excavations were made to verify the locations shown for underground utilities. The service connections to these utilities are not shown on the Plans. Water service connections may be shown on the Plans showing general locations of such connections. It shall be the responsibility of the Contractor to determine the exact location of all service connections. The Contractor shall make its own investigations, including exploratory excavations, to determine the locations and type of service connections, prior to commencing Work which could result in damage to such utilities. The Contractor shall immediately notify the District in writing of any utility discovered in a different position than shown on the Plans or which is not shown on the Plans.
- C. If applicable, all water meters, water valves, fire hydrants, electrical utility vaults, telephone vaults, gas utility valves, and other subsurface structures shall be relocated or adjusted to final grade by the Contractor. Locations of existing utilities shown on the Plans are approximate and may not be complete. The Contractor shall be responsible for coordinating its Work with all utility companies during the construction of the Work.
- D. Notwithstanding the above, pursuant to section 4215 of the Government Code, the District has the responsibility to identify, with reasonable accuracy, main or trunk line facilities on the plans and specifications. In the event that main or trunk line utility facilities are not identified with reasonable accuracy in the plans and specifications made a part of the invitation for Bids, the District shall assume the responsibility for their timely removal, relocation, or protection.
- E. Contractor, except in an emergency, shall contact the appropriate regional notification center, **Southern California Underground Service Alert** at 811 or 1-800-227-2600 or on-line at www.digalert.org at least two working days prior to commencing any excavation if the excavation will be performed in an area which is known, or reasonably should be known, to contain subsurface installations other than the underground facilities owned or operated by the District, and obtain an inquiry identification number from that notification center. No

GENERAL CONDITIONS
SECTION F- LABOR AND CONSTRUCTION

excavation shall be commenced or carried out by the Contractor unless such an inquiry identification number has been assigned to the Contractor or any subcontractor of the Contractor and the District has been given the identification number by the Contractor.

ARTICLE 8 SOILS INVESTIGATIONS

- A. Reports and Drawings. The Special Conditions identify:
1. those reports known to the District of explorations and tests of subsurface conditions at or contiguous to the site; and
 2. those drawings known to the District of physical conditions relating to existing surface or subsurface structures at the site (except Underground Facilities).
- B. Limited Reliance by Contractor on Technical Data Authorized. Contractor may rely upon the accuracy of the "technical data" contained in such reports and drawings, which were expressly not created or obtained to evaluate or assist in the evaluation of constructability, and are not Contract Documents. Contractor shall make its own interpretation of the "technical data" and shall be solely responsible for any such interpretations. Except for reliance on the accuracy of such "technical data," Contractor may not rely upon or make any claim against the District, District's Representative, or Engineer of Record, or any of their officers, directors, members, partners, employees, agents, consultants, or subcontractors, with respect to:
1. the completeness of such reports and drawings for Contractor's purposes, including without limitation any aspects of the means, methods, techniques, sequences, and procedures of construction to be employed by Contractor, and safety precautions and programs incident thereto; or
 2. other data, interpretations, opinions, conclusions and information contained in such reports or shown or indicated in such drawings; or
 3. any Contractor interpretation of or conclusion drawn from any "technical data" or any such other data, interpretations, opinions, or information.

ARTICLE 9 CONTRACTOR'S SUPERVISION

Contractor shall continuously keep at the Project site, a competent and experienced full-time Project superintendent acceptable to the District. Superintendent must be able to proficiently speak, read and write in English and shall have the authority to make decisions on behalf of the Contractor. Contractor shall continuously provide efficient supervision of the Project.

ARTICLE 10 WORKERS

- A. Contractor shall at all times enforce strict discipline and good order among its employees. Contractor shall not employ on the Project any unfit person or any one not skilled in the Work assigned to him or her.

GENERAL CONDITIONS
SECTION F- LABOR AND CONSTRUCTION

- B. Any person in the employ of the Contractor whom the District may deem incompetent or unfit shall be dismissed from the Work and shall not be employed on this Project.

ARTICLE 11 INDEPENDENT CONTRACTORS

Contractor shall be an independent contractor for the District and not an employee. Contractor understands and agrees that it and all of its employees shall not be considered officers, employees, or agents of District and are not entitled to benefits of any kind normally provided employees of District, including but not limited to, state unemployment compensation or workers' compensation. Contractor assumes full responsibility for the acts and omissions of its employees or agents related to the Work.

ARTICLE 12 SUBCONTRACTS

- A. Contractor agrees to bind every subcontractor to the terms of the Contract Documents as far as such terms are applicable to subcontractor's portion of the Work. Contractor shall be as fully responsible to the District for the acts and omissions of its subcontractors and of persons either directly or indirectly employed by its subcontractors, as Contractor is for acts and omissions of persons directly employed by Contractor. Nothing contained in these Contract Documents shall create any contractual relationship between any subcontractor and the District.
- B. The District reserves the right to accept all subcontractors. The District's acceptance of any subcontractor under this Contract shall not in any way relieve Contractor of its obligations in the Contract Documents.
- C. Prior to substituting any subcontractor listed in the Bid Forms, Contractor must comply with the requirements of the Subletting and Subcontracting Fair Practices Act pursuant to California Public Contract Code section 4100 et seq.

ARTICLE 13 VERIFICATION OF EMPLOYMENT ELIGIBILITY

By executing this Contract, Contractor verifies that it fully complies with all requirements and restrictions of state and federal law respecting the employment of undocumented aliens, including, but not limited to, the Immigration Reform and Control Act of 1986, as may be amended from time to time, and shall require all subcontractors, sub-subcontractors and consultants to comply with the same. Each person executing this Contract on behalf of Contractor verifies that he or she is a duly authorized officer of Contractor and that any of the following shall be grounds for the District to terminate the Contract for cause: (1) failure of the Contractor or its subcontractors, sub-subcontractors or consultants to meet any of the requirements provided for in this Article; (2) any misrepresentation or material omission concerning compliance with such requirements; or (3) failure to immediately remove from the Work any person found not to be in compliance with such requirements.

ARTICLE 14 REQUESTS FOR SUBSTITUTION

- A. For the purposes of this provision, the term "substitution" shall mean the substitution of any material, method or service substantially equal to or better in

GENERAL CONDITIONS
SECTION F- LABOR AND CONSTRUCTION

every respect to that indicated in the Standard Specifications or otherwise referenced herein.

- B. Pursuant to Public Contract Code section 3400(b), the District may make a finding that is described in the Notice Inviting Bids that designates certain products, things, or services by specific brand or trade name.
- C. Unless specifically designated in the Special Conditions, whenever any material, process, or article is indicated or specified by grade, patent, or proprietary name or by name of manufacturer, such specifications shall be deemed to be used for the purpose of facilitating the description of the material, process, or article desired and shall be deemed to be followed by the words "or equal." Contractor may, unless otherwise stated, offer for substitution any material, process, or article which may be substantially equal to or better in every respect to that so indicated or specified in the Contract Documents. However, the District has adopted uniform standards for certain materials, processes, and articles.
- D. The Contractor shall submit substitution requests, together with substantiating data, for substitution of any "or equal" material, process, or article no later than thirty-five (35) calendar days after award of Contract. Provisions regarding submission of substitution requests shall not in any way authorize an extension of time for the performance of this Contract. If a substitution request is rejected by the District, the Contractor shall provide the material, method or service specified herein. The District shall not be responsible for any costs incurred by the Contractor associated with substitution requests. The burden of proof as to the equality of any material, process, or article shall rest with the Contractor. The Engineer has the complete and sole discretion to determine if a material, process, or article is substantially equal to or better than that specified and to approve or reject all substitution requests.
- E. Substantiating data as described above shall include, at a minimum, the following information:
 - 1. A signed affidavit from the Contractor stating that the material, process, or article proposed as a substitution is substantially equal to or better than that specified in every way except as may be listed on the affidavit.
 - 2. Illustrations, specifications, catalog cut sheets, and any other relevant data required to prove that the material, process, or article is substantially equal to or better than that specified.
 - 3. A statement of the cost implications of the substitution being requested, indicating whether and why the proposed substitution will reduce or increase the amount of the contract.
 - 4. Information detailing the durability and lifecycle costs of the proposed substitution.
- F. Failure to submit all the required substantiating data detailed above in a timely manner so that the substitution request can be adequately reviewed may result

GENERAL CONDITIONS
SECTION F- LABOR AND CONSTRUCTION

in rejection of the substitution request. The Engineer is not obligated to review multiple submittals related the same substitution request resulting from the Contractor's failure to initially submit a complete package.

- G. Time limitations within this Article shall be strictly complied with and in no case will an extension of time for completion of the contract be granted because of Contractor's failure to provide substitution requests at the time and in the manner described herein.
- H. The Contractor shall bear the costs of all District work associated with the review of substitution requests.
- I. If substitution requests approved by the Engineer require that Contractor furnish materials, methods or services more expensive than that specified, the increased costs shall be borne by Contractor.

ARTICLE 15 SHOP DRAWINGS

- A. Contractor shall check and verify all field measurements and shall submit with such promptness as to provide adequate time for review and cause no delay in its own Work or in that of any other contractor, subcontractor, or worker on the Project, six (6) copies of all shop drawings, calculations, schedules, and materials list, and all other provisions required by the Contract Documents. Contractor shall sign all submittals affirming that submittals have been reviewed and approved by Contractor prior to submission to Engineer. Each signed submittal shall affirm that the submittal meets all the requirements of the Contract Documents except as specifically and clearly noted and listed on the transmittal letter of the submittal.
- B. Contractor shall make any corrections required by the Engineer, and file with the Engineer six (6) corrected copies each, and furnish such other copies as may be needed for completion of the Work. Engineer's acceptance of shop drawings shall not relieve Contractor from responsibility for deviations from the Contract Documents unless Contractor has, in writing, called Engineer's attention to such deviations at time of submission and has secured the Engineer's written acceptance. Engineer's acceptance of shop drawings shall not relieve Contractor from responsibility for errors in shop drawings.

ARTICLE 16 SUBMITTALS

- A. Contractor shall furnish to the Engineer for approval, prior to purchasing or commencing any Work, a log of all samples, material lists and certifications, mix designs, schedules, and other submittals, as required in the Contract Documents. The log shall indicate whether samples will be provided in accordance with other provisions of this Contract.
- B. Contractor will provide samples and submittals, together with catalogs and supporting data required by the Engineer, to the Engineer within a reasonable time period to provide for adequate review and avoid delays in the Work.

GENERAL CONDITIONS
SECTION F- LABOR AND CONSTRUCTION

- C. These requirements shall not authorize any extension of time for performance of this Contract. Engineer will check and approve such samples, but only for conformance with design concept of work and for compliance with information given in the Contract Documents. Work shall be in accordance with approved samples and submittals.

ARTICLE 17 MATERIALS

- A. Except as otherwise specifically stated in the Contract Documents, Contractor shall provide and pay for all materials, labor, tools, equipment, lights, power, transportation, superintendence, temporary constructions of every nature, and all other services and facilities of every nature whatsoever necessary to execute and complete this Contract within specified time.
- B. Unless otherwise specified, all materials shall be new and the best of their respective kinds and grades as noted and/or specified, and workmanship shall be of good quality.
- C. Materials shall be furnished in ample quantities and at such times as to ensure uninterrupted progress of the Work and shall be stored properly and protected as required by the Contract Documents. Contractor shall be entirely responsible for damage or loss by weather or other causes to materials or Work.
- D. No materials, supplies, or equipment for Work under this Contract shall be purchased subject to any chattel mortgage or under a conditional sale or other agreement by which an interest therein or in any part thereof is retained by the seller or supplier. Contractor warrants good title to all material, supplies, and equipment installed or incorporated in the Work and agrees upon completion of all work to deliver the Project, to the District free from any claims, liens, or charges.
- E. Materials shall be stored on the Project site in such manner so as not to interfere with any operations of the District or any independent contractor.
- F. Contractor shall verify all measurements, dimensions, elevations, and quantities before ordering any materials or performing any Work, and the District shall not be liable for Contractor's failure to do so. No additional compensation, over and above payment for the actual quantities at the prices set out in the Bid Form, will be allowed because of differences between actual measurements, dimension, elevations and quantities and those indicated on the Plans and in the Specifications. Any difference therein shall be submitted to the Engineer for consideration before proceeding with the Work.

ARTICLE 18 PERMITS AND LICENSES

- A. District will apply and pay for the review of necessary encroachment permits for Work within the public rights-of-way. Contractor shall obtain all other necessary permits and licenses for the construction of the Project, including encroachment permits, and shall pay all fees required by law and shall comply with all laws, ordinances, rules and regulations relating to the Work and to the preservation of

GENERAL CONDITIONS
SECTION F- LABOR AND CONSTRUCTION

public health and safety. Before acceptance of the Project, the Contractor shall submit all licenses, permits, certificates of inspection and required approvals to the District.

- B. The Bid Form contains an allowance for the Contractor's cost of acquiring traffic control permits and for construction inspection fees that may be charged to the Contractor by the Agency of Jurisdiction. The allowance is included within the Bid Form to eliminate the need by bidders to research or estimate the costs of traffic control permits and construction inspection fees prior to submitting a bid. The allowance is specifically intended to account for the costs of traffic control permits and construction inspection fees charged by the local Agency of Jurisdiction only. No other costs payable by Contractor to the Agency of Jurisdiction are included within the allowance. Payment by District to Contractor under the Permit and Inspection Allowance Bid Item shall be made based on actual cost receipts only and in accordance with the provisions of these specifications.

ARTICLE 19 TRENCHES

- A. Trenches Five Feet or More in Depth.** Contractor shall submit to the Engineer at the preconstruction meeting, a detailed plan showing the design of shoring, bracing, sloping or other provisions to be made for worker protection from hazards of caving ground during the excavation of any trench or trenches five feet or more in depth. If such plan varies from shoring system standards established by the Construction Safety Orders of the California Code of Regulations, Department of Industrial Relations, the plan shall be prepared by a California registered civil or structural engineer. The plan shall not be less effective than the shoring, bracing, sloping, or other provisions of the Construction Safety Orders, as defined in the California Code of Regulations. The Contractor shall designate in writing the "competent person" as defined in Title 8, California Code of Regulations, who shall be present at the Work Site each day that trenching/excavation is in progress. The "competent person" shall prepare and provide daily trenching/excavation inspection reports to the Engineer. Contractor shall also submit a copy of its annual California Occupational Safety and Health Administration (Cal/OSHA) trench/excavation permit.
- B. Excavations Deeper than Four Feet.** If the Work involves excavating trenches or other excavations that extend deeper than four feet below the surface, Contractor shall promptly, and before the excavation is further disturbed, notify the District in writing of any of the following conditions:
- C. Material that the Contractor believes may be material that is hazardous waste, as defined in section 25117 of the Health and Safety Code, that is required to be removed to a Class I, Class II, or Class III disposal site in accordance with provisions of existing law.
1. Subsurface or latent physical conditions at the site differing from those indicated.

GENERAL CONDITIONS
SECTION F- LABOR AND CONSTRUCTION

2. Unknown physical conditions at the site of any unusual nature, different materially from those ordinarily encountered and generally recognized as inherent in work of the character provided for in the Contract

The District shall promptly investigate the conditions, and if it finds that the conditions do so materially differ, or do involve hazardous waste, and cause a decrease or increase in Contractor's cost of, or the time required for, performance of any part of the Work, shall issue a change order under the procedures described in the Contract Documents.

In the event that a dispute arises between the District and the Contractor as to whether the conditions materially differ, or involve hazardous waste, or cause a decrease or increase in the Contractor's cost of, or time required for, performance of any part of the Work, the Contractor shall not be excused from any scheduled completion date provided for by the Contract, but shall proceed with all Work to be performed under the Contract. Contractor shall retain any and all rights provided either by contract or by law which pertain to the resolution of disputes and protests between the parties.

ARTICLE 20 TRAFFIC CONTROL

- A. Traffic control plan(s) for the Work may be required by the Agency(s) of Jurisdiction. Traffic control plans, if required, shall be prepared at Contractor's expense, and traffic control shall be performed at Contractor's expense in accordance with the requirements of the Agency(s) of Jurisdiction. The Permit and Inspection Allowance included within the Bid Form includes the cost of required traffic control permit(s) and construction inspection by the Agency(s) of Jurisdiction only. The Permit and Inspection Allowance does not include costs for preparation of any required traffic control plans, implementation of any traffic control requirements or for any traffic signal services that may be required. Costs for traffic control plans, implementation of traffic control, or traffic signal services required by the Agency(s) of Jurisdiction shall be included in the Contractor's Bid.
- B. All warning signs and safety devices used by the Contractor to perform the Work shall conform to the requirements contained in the State of California, Department of Transportation's current edition of "Manual of Traffic Controls for Construction and Maintenance Work Zones" or to the requirements of the local agency. The Contractor shall also be responsible for all traffic control required by the agency having jurisdiction over the project on the intersecting streets. Contractor must submit a traffic control plan to the agency having jurisdiction over the project for approval prior to starting work.
- C. The Contractor's representative on the site responsible for traffic control shall produce evidence that he/she has completed training acceptable to the California Department of Transportation for safety through construction zones. All of the streets in which the Work will occur shall remain open to traffic and one lane of traffic maintained at all times unless otherwise directed by the agency of jurisdiction. Businesses and residences adjacent to the Work shall be notified forty-eight (48) hours in advance of closing of driveways. The Contractor

GENERAL CONDITIONS
SECTION F- LABOR AND CONSTRUCTION

shall make every effort to minimize the amount of public parking temporarily eliminated due to construction in areas fronting businesses. No stockpiles of pipe or other material will be allowed in traveled right-of-ways after working hours unless otherwise approved by the Engineer.

ARTICLE 21 DIVERSION OF RECYCLABLE WASTE MATERIALS

In compliance with the applicable District's waste reduction and recycling efforts, Contractor shall divert all Recyclable Waste Materials to appropriate recycling centers as required for compliance with the local jurisdiction's waste diversion ordinances. Contractor will be required to submit weight tickets and written proof of diversion with its monthly progress payment requests. Contractor shall complete and execute any certification forms required by District or other applicable agencies to document Contractor's compliance with these diversion requirements. All costs incurred for these waste diversion efforts shall be the responsibility of the Contractor.

ARTICLE 22 REMOVAL OF HAZARDOUS MATERIALS

Should Contractor encounter material reasonably believed to be polychlorinated biphenyl (PCB) or other toxic wastes and hazardous materials which have not been rendered harmless at the Project site, the Contractor shall immediately stop work at the affected Project site and shall report the condition to the District in writing. The District shall contract for any services required to directly remove and/or abate PCBs and other toxic wastes and hazardous materials, if required by the Project site(s), and shall not require the Contractor to subcontract for such services. The Work in the affected area shall not thereafter be resumed except by written agreement of the District and Contractor.

ARTICLE 23 SANITARY FACILITIES

Contractor shall provide sanitary temporary toilet buildings and hand washing facilities for the use of all workers. All toilets and hand washing facilities shall comply with local codes and ordinances. Toilets shall be kept supplied with toilet paper and shall have workable door fasteners. Toilets and hand washing facilities shall be serviced no less than once weekly and shall be present in a quantity of not less than 1 per 20 workers as required by Cal/OSHA regulations. The toilets and hand washing facilities shall be maintained in a sanitary condition at all times. Use of toilet and hand washing facilities in the Work under construction shall not be permitted. Any other Sanitary Facilities required by Cal/OSHA shall be the responsibility of the Contractor.

ARTICLE 24 AIR POLLUTION CONTROL

Contractor shall comply with all air pollution control rules, regulations, ordinances and statutes, including, but not limited to, those required by the South Coast Air Quality Management District. All containers of paint, thinner, curing compound, solvent or liquid asphalt shall be labeled to indicate that the contents fully comply with the applicable material requirements.

ARTICLE 25 LAYOUT AND FIELD ENGINEERING

All field engineering required for laying out the Work and establishing grades for earthwork operations shall be furnished by the Contractor at its expense.

GENERAL CONDITIONS
SECTION F- LABOR AND CONSTRUCTION

ARTICLE 26 TESTS AND INSPECTIONS

- A. If the Contract Documents, the Engineer, or any instructions, laws, ordinances, or public authority requires any part of the Work to be tested or Approved, Contractor shall provide the Engineer at least two (2) working days' notice of its readiness for observation or inspection. If inspection is by a public authority other than the District, Contractor shall promptly inform the District of the date fixed for such inspection. Required certificates of inspection (or similar) shall be secured by Contractor. Costs for District testing and District inspection shall be paid by the District. Costs of tests for Work found not to be in compliance shall be paid by the Contractor.
- B. If any Work is done or covered up without the required testing or approval, the Contractor shall uncover or deconstruct the Work, and the Work shall be redone after completion of the testing at the Contractor's cost in compliance with the Contract Documents.
- C. Where inspection and testing are to be conducted by an independent laboratory or agency, materials or samples of materials to be inspected or tested shall be selected by such laboratory or agency, or by the District, and not by Contractor. All tests or inspections of materials shall be made in accordance with the commonly recognized standards of national organizations.
- D. In advance of manufacture of materials to be supplied by Contractor which must be tested or inspected, Contractor shall notify the District so that the District may arrange for testing at the source of supply. Any materials which have not satisfactorily passed such testing and inspection shall not be incorporated into the Work.
- E. If the manufacture of materials to be inspected or tested will occur in a plant or location greater than sixty (60) miles from the District, the Contractor shall pay for any excessive or unusual costs associated with such testing or inspection, including but not limited to excessive travel time, standby time and required lodging.
- F. Reexamination of Work may be ordered by the District. If so ordered, Work must be uncovered or deconstructed by Contractor. If Work is found to be in accordance with the Contract Documents, the District shall pay the costs of reexamination and reconstruction. If such work is found not to be in accordance with the Contract Documents, Contractor shall pay all costs.

ARTICLE 27 PROTECTION OF WORK AND PROPERTY

- A. The Contractor shall be responsible for all damages to persons or property that occurs as a result of the Work. Contractor shall be responsible for the proper care and protection of all materials delivered and Work performed until completion and final Acceptance by the District. All Work shall be solely at the Contractor's risk. Contractor shall adequately protect adjacent property from settlement or loss of lateral support as necessary. Contractor shall comply with all applicable safety laws and building codes to prevent accidents or injury to

GENERAL CONDITIONS
SECTION F- LABOR AND CONSTRUCTION

persons on, about, or adjacent to the Project site where Work is being performed. Contractor shall erect and properly maintain at all times, as required by field conditions and progress of work, all necessary safeguards, signs, barriers, lights, and watchmen for protection of workers and the public, and shall post danger signs warning against hazards created in the course of construction.

- B. In an emergency affecting safety of life or of work or of adjoining property, Contractor, without special instruction or authorization from the Engineer, is hereby permitted to act to prevent such threatened loss or injury; and Contractor shall so act, without appeal, if so authorized or instructed by the Engineer or the District. Any compensation claimed by Contractor on account of emergency work shall be determined by and agreed upon by the District and the Contractor.

ARTICLE 28 CONTRACTOR'S MEANS AND METHODS

Contractor is solely responsible for the means and methods utilized to perform the Work. In no case shall the Contractor's means and methods deviate from commonly used industry standards.

ARTICLE 29 AUTHORIZED REPRESENTATIVES

The District shall designate representatives, who shall have the right to be present at the Project site at all times. The District may designate an inspector who shall have the right to observe all of the Contractor's Work. The inspector shall not be responsible for the Contractor's failure to carry out the Work in accordance with the Contract Documents. Contractor shall provide safe and proper facilities for such access.

ARTICLE 30 HOURS OF WORK

- A. As provided in Article 3 (commencing at section 1810), Chapter 1, Part 7, Division 2 of the Labor Code, Contractor stipulates that eight (8) hours of labor shall constitute a legal day's work. The time of service of any worker employed at any time by the Contractor or by any subcontractor on any subcontract under this Contract upon the Work or upon any part of the Work contemplated by this Contract is limited and restricted to eight (8) hours during any one calendar day and 40 hours during any one calendar week, except as hereinafter provided. Notwithstanding the provisions herein above set forth, work performed by employees of Contractor in excess of eight (8) hours per day, and 40 hours during any one week, shall be permitted upon this public work upon compensation for all hours worked in excess of eight (8) hours per day at not less than one and one-half times the basic rate of pay.
- B. The Contractor and every subcontractor shall keep an accurate record showing the name of and actual hours worked each calendar day and each calendar week by each worker employed in connection with the Work or any part of the Work contemplated by this Contract. The record shall be kept open at all reasonable hours to the inspection of the District and to the Division of Labor Law Enforcement, Department of Industrial Relations of the State of California.

GENERAL CONDITIONS
SECTION F- LABOR AND CONSTRUCTION

- C. The Contractor shall pay to the District a penalty of twenty-five dollars (\$25.00) for each worker employed in the execution of this Contract by the Contractor or by any subcontractor for each calendar day during which such worker is required or permitted to work more than eight (8) hours in any calendar day and 40 hours in any one calendar week in violation of the provisions of Article 3 (commencing at section 1810), Chapter 1, Part 7, Division 2 of the Labor Code.
- D. Any work necessary to be performed after regular working hours, or on Saturdays and Sundays or other holidays, shall be performed without additional expense to the District.
- E. District will provide inspection during normal working hours from 7:00 a.m. to 3:30 p.m. Monday through Friday. Inspection before or after this time will be charged to the Contractor as reimbursable inspection time. Inspections on weekends requires two days' notice for review and approval. Upon written request and approval the 8.5 hour working day may be changed to other limits subject to city/county ordinance.
- F. It shall be unlawful for any person to operate, permit, use, or cause to operate any of the following at the Project site, other than between the hours of 7:00 a.m. to 5:00 p.m., Monday through Friday, with no Work allowed on the District-observed holidays, unless otherwise approved by the District:
 - 1. Powered Vehicles
 - 2. Construction Equipment
 - 3. Loading and Unloading Vehicles
 - 4. Domestic Power Tools

ARTICLE 31 PAYROLL RECORDS

- A. Pursuant to Labor Code section 1776, Contractor and all subcontractors shall maintain weekly certified payroll records, showing the names, addresses, Social Security numbers, work classifications, straight time and overtime hours worked each day and week, and the actual per diem wages paid to each journeyman, apprentice, worker, or other employee employed by them in connection with the Work under this Contract. Contractor shall certify under penalty of perjury that records maintained and submitted by Contractor are true and accurate. Contractor shall also require subcontractor(s) to certify weekly payroll records under penalty of perjury.
- B. In accordance with Labor Code section 1771.4, the Contractor and each subcontractor shall furnish the certified payroll records directly to the Department of Industrial Relations ("DIR") on the specified interval and format prescribed by the DIR, which may include electronic submission. Contractor shall comply with all requirements and regulations from the DIR relating to labor compliance monitoring and enforcement.

GENERAL CONDITIONS
SECTION F- LABOR AND CONSTRUCTION

- C. The payroll records described herein shall be certified and submitted by the Contractor at a time designated by the District. The Contractor shall also provide the following:
 - 1. A certified copy of the employee's payroll records shall be made available for inspection or furnished to such employee or his or her authorized representative on request.
 - 2. A certified copy of all payroll records described herein shall be made available for inspection or furnished upon request of the DIR.
- D. Unless submitted electronically, the certified payroll records shall be on forms provided by the Division of Labor Standards Enforcement ("DLSE") of the DIR or shall contain the same information as the forms provided by the DLSE.
- E. Any copy of records made available for inspection as copies and furnished upon request to the public or any public agency, the District, the Division of Apprenticeship Standards or the Division of Labor Standards Enforcement shall be marked or obliterated in such a manner as to prevent disclosure of an individual's name, address and social security number. The name and address of the Contractor awarded the Contract or performing the contract shall not be marked or obliterated.
- F. In the event of noncompliance with the requirements of this Article, the Contractor shall have ten (10) calendar days in which to comply subsequent to receipt of written notice specifying in what respects the Contractor must comply with this Article. Should noncompliance still be evident after such 10-day period, the Contractor shall pay a penalty of one hundred dollars (\$100.00) to the District for each calendar day, or portion thereof, for each worker, until strict compliance is effectuated. Upon the request of the Division of Apprenticeship Standards or the Division of Labor Standards Enforcement, such penalties shall be withheld from progress payment then due.
- G. The responsibility for compliance with this Article shall rest upon the Contractor.

ARTICLE 32 PREVAILING RATES OF WAGES

- A. The Contractor is aware of the requirements of Labor Code sections 1720 *et seq.* and 1770 *et seq.*, as well as California Code of Regulations, Title 8, Section 16000 *et seq.* ("Prevailing Wage Laws"), which require the payment of prevailing wage rates and the performance of other requirements on certain "public works" and "maintenance" projects. Since this Project involves an applicable "public works" or "maintenance" project, as defined by the Prevailing Wage Laws, and since the total compensation is \$1,000 or more, Contractor agrees to fully comply with such Prevailing Wage Laws. The Contractor shall obtain a copy of the prevailing rates of per diem wages at the commencement of this Contract from the website of the Division of Labor Statistics and Research of the Department of Industrial Relations located at www.dir.ca.gov. In the alternative, the Contractor may view a copy of the prevailing rate of per diem wages which are on file at the District's Administration Office and shall be made available to

GENERAL CONDITIONS
SECTION F- LABOR AND CONSTRUCTION

interested parties upon request. Contractor shall make copies of the prevailing rates of per diem wages for each craft, classification, or type of worker needed to perform work on the Project available to interested parties upon request, and shall post copies at the Contractor's principal place of business and at the Project site. Contractor shall defend, indemnify and hold the District, its officials, officers, employees and authorized volunteers free and harmless from any claims, liabilities, costs, penalties or interest arising out of any failure or alleged failure to comply with the Prevailing Wage Laws.

- B. The Contractor shall forfeit as a penalty to the District not more than Two Hundred Dollars (\$200.00), pursuant to Labor Code section 1775, for each calendar day, or portion thereof, for each worker paid less than the prevailing wage rate as determined by the Director of the Department of Industrial Relations for such work or craft in which such worker is employed for any public work done under the Contract by it or by any subcontractor under it. The difference between such prevailing wage rate and the amount paid to each worker for each calendar day or portion thereof, for which each worker was paid less than the prevailing wage rate, shall be paid to each worker by the Contractor.
- C. Contractor shall post, at appropriate conspicuous points on the Project site, a schedule showing all determined general prevailing wage rates and all authorized deductions, if any, from unpaid wages actually earned.

ARTICLE 33 PUBLIC WORKS CONTRACTOR REGISTRATION

Pursuant to Labor Code sections 1725.5 and 1771.1, the Contractor and its subcontractors must be registered with the Department of Industrial Relations prior to the execution of a contract to perform public works. By entering into this Contract, Contractor represents that it is aware of the registration requirement and is currently registered with the DIR. Contractor shall maintain a current registration for the duration of the Project. Contractor shall further include the requirements of Labor Code sections 1725.5 and 1771.1 in any subcontract and ensure that all subcontractors are registered at the time this Contract is entered into and maintain registration for the duration of the Project.

ARTICLE 34 EMPLOYMENT OF APPRENTICES

- A. Contractor and all subcontractors shall comply with the requirements of Labor Code sections 1777.5 and 1777.6 in the employment of apprentices.
- B. Information relative to apprenticeship standards, wage schedules, and other requirements may be obtained from the Director of Industrial Relations, ex officio the Administrator of Apprenticeship, San Francisco, California, or from the Division of Apprenticeship Standards and its branch offices.
- C. Knowing violations of Labor Code section 1777.5 will result in forfeiture not to exceed one hundred dollars (\$100.00) for each calendar day of non-compliance pursuant to Labor Code section 1777.7.
- D. The responsibility for compliance with this Article shall rest upon the Contractor.

GENERAL CONDITIONS
SECTION F- LABOR AND CONSTRUCTION

ARTICLE 35 NONDISCRIMINATION/EQUAL EMPLOYMENT OPPORTUNITY

Pursuant to Labor Code section 1735 and other applicable provisions of law, the Contractor and its subcontractors shall not discriminate against any employee or applicant for employment because of race, religious creed, color, national origin, ancestry, physical disability, mental disability, medical condition, marital status, sex, age, sexual orientation, or any other classifications protected by law on this Project. The Contractor will take affirmative action to insure that employees are treated during employment or training without regard to their race, religious creed, color, national origin, ancestry, physical disability, mental disability, medical condition, marital status, sex, age, sexual orientation, or any other classifications protected by law.

Employment Eligibility; Contractor. By executing this Contract, Contractor verifies that it fully complies with all requirements and restrictions of state and federal law respecting the employment of undocumented aliens, including, but not limited to, the Immigration Reform and Control Act of 1986, as may be amended from time to time. Such requirements and restrictions include, but are not limited to, examination and retention of documentation confirming the identity and immigration status of each employee of the Contractor. Contractor also verifies that it has not committed a violation of any such law within the five (5) years immediately preceding the date of execution of this Contract, and shall not violate any such law at any time during the term of the Contract. Contractor shall avoid any violation of any such law during the term of this Contract by participating in an electronic verification of work authorization program operated by the United States Department of Homeland Security, by participating in an equivalent federal work authorization program operated by the United States Department of Homeland Security to verify information of newly hired employees, or by some other legally acceptable method. Contractor shall maintain records of each such verification, and shall make them available to the District or its representatives for inspection and copy at any time during normal business hours. The District shall not be responsible for any costs or expenses related to Contractor's compliance with the requirements provided for or referred to herein.

Employment Eligibility; Subcontractors, Sub-subcontractors and Consultants. To the same extent and under the same conditions as Contractor, Contractor shall require all of its subcontractors, sub-subcontractors and consultants performing any part of the Work or of this Contract to make the same verifications and comply with all requirements and restrictions provided for herein.

Employment Eligibility; Failure to Comply. Each person executing this Contract on behalf of Contractor verifies that he or she is a duly authorized officer of Contractor, and understands that any of the following shall be grounds for the District to terminate the Contract for cause: (1) failure of Contractor or its subcontractors, sub-subcontractors or consultants to meet any of the requirements provided for herein; (2) any misrepresentation or material omission concerning compliance with such requirements; or (3) failure to immediately remove from the Work any person found not to be in compliance with such requirements.

ARTICLE 36 DEBARMENT OF CONTRACTORS AND SUBCONTRACTORS

Contractors or subcontractors may not perform work on a public works project with a subcontractor who is ineligible to perform work on a public project pursuant to Labor Code section 1777.1 or 1777.7. Any contract on a public works project entered into between a contractor and a debarred subcontractor is void as a matter of law. A debarred subcontractor

GENERAL CONDITIONS
SECTION F- LABOR AND CONSTRUCTION

may not receive any public money for performing work as a subcontractor on a public works contract. Any public money that is paid, or may have been paid to a debarred subcontractor by a contractor on the project shall be returned to the District. The Contractor shall be responsible for the payment of wages to workers of a debarred subcontractor who has been allowed to work on the project.

ARTICLE 37 LABOR/EMPLOYMENT SAFETY

The Contractor shall comply with all applicable laws and regulations of the federal, state, and local government, including Cal/OSHA requirements and requirements for verification of employees' legal right to work in the United States.

The Contractor shall maintain emergency first aid treatment for his employees which complies with the Federal Occupational Safety and Health Act of 1970 (29 U.S.C. § 651 *et seq.*), and California Code of Regulations, Title 8, Industrial Relations Division 1, Department of Industrial Relations, Chapter 4. The Contractor shall ensure the availability of emergency medical services for its employees in accordance with California Code of Regulations, Title 8, Section 1512.

The Contractor shall submit the Illness and Injury Prevention Program and a Project site specific safety program to the District prior to beginning Work at the Project site. Contractor shall maintain a confined space program that meets or exceeds the District Standards. Contractor shall adhere to the District's lock out tag out program.

ARTICLE 38 INSURANCE

The Contractor shall obtain, and at all times during performance of the Work of Contract, maintain all of the insurance described in this Article. Contractor shall not commence Work under this Contract until it has provided evidence satisfactory to the District that it has secured all insurance required hereunder. Contractor shall not allow any subcontractor to commence work on any subcontract until it has provided evidence satisfactory to the District that the subcontractor has secured all insurance required under this Article. Failure to provide and maintain all required insurance shall be grounds for the District to terminate this Contract for cause. Contractor shall furnish District with original certificates of insurance and endorsements effective coverage required by this Contract on forms satisfactory to the District. The certificates and endorsements for each insurance policy shall be signed by a person authorized by that insurer to bind coverage on its behalf, and shall be on forms acceptable to the District. All certificates and endorsements must be received and approved by the District before Work commences.

- A. **Additional Insureds; Waiver of Subrogation.** The District, its officials, officers, employees, agents and authorized volunteers shall be named as Additional Insureds on Contractor's All Risk policy and on Contractor's and its subcontractors' policies of Commercial General Liability and Automobile Liability insurance using, for Contractor's policy/ies of Commercial General Liability insurance, ISO CG forms 20 10 and 20 37 (or endorsements providing the exact same coverage, including completed operations), and, for subcontractors' policies of Commercial General Liability insurance, ISO CG form 20 38 (or endorsements providing the exact same coverage). Notwithstanding the minimum limits set forth in this Contract for any type of insurance coverage, all

GENERAL CONDITIONS
SECTION F- LABOR AND CONSTRUCTION

available insurance proceeds in excess of the specified minimum limits of coverage shall be available to the parties required to be named as Additional Insureds hereunder. Contractor and its insurance carriers shall provide a Waiver of Subrogation in favor of those parties.

- B. Workers' Compensation Insurance.** The Contractor shall provide workers' compensation insurance for all of the employees engaged in Work under this Contract, on or at the Site, and, in case of any sublet Work, the Contractor shall require the subcontractor similarly to provide workers' compensation insurance for all the latter's employees as prescribed by State law. Any class of employee or employees not covered by a subcontractor's insurance shall be covered by the Contractor's insurance. In case any class of employees engaged in work under this Contract, on or at the Site, is not protected under the Workers' Compensation Statutes, the Contractor shall provide or shall cause a subcontractor to provide, adequate insurance coverage for the protection of such employees not otherwise protected. The Contractor is required to secure payment of compensation to his employees in accordance with the provisions of section 3700 of the Labor Code. The Contractor shall file with the District certificates of his insurance protecting workers. Company or companies providing insurance coverage shall be acceptable to the District, if in the form and coverage as set forth in the Contract Documents.
- C. Employer's Liability Insurance.** Contractor shall provide Employer's Liability Insurance, including Occupational Disease, in the amount of at least one million dollars (\$1,000,000.00) per person per accident. Contractor shall provide District with a certificate of Employer's Liability Insurance. Such insurance shall comply with the provisions of the Contract Documents. The policy shall be endorsed, if applicable, to provide a Borrowed Servant/Alternate Employer Endorsement and contain a Waiver of Subrogation in favor of the District.
- D. Commercial General Liability Insurance.** Contractor shall provide "occurrence" form Commercial General Liability insurance coverage at least as broad as the most current ISO CGL Form 00 01, including but not limited to, premises liability, contractual liability, products/completed operations, personal and advertising injury which may arise from or out of Contractor's operations, use, and management of the Site, or the performance of its obligations hereunder. The policy shall not contain any exclusion contrary to this Contract including but not limited to endorsements or provisions limiting coverage for (1) contractual liability (including but not limited to ISO CG 24 26 or 21 39); or (2) cross-liability for claims or suits against one insured against another. Policy limits shall not be less than \$1,000,000 per occurrence for bodily injury, personal injury and property damage. If Commercial General Liability Insurance or other form with a general aggregate limit is used, either the general aggregate limit shall apply separately to this project/location or the general aggregate limit shall be twice the required occurrence limit. Defense costs shall be paid in addition to the limits.
1. Such policy shall comply with all the requirements of this Article. The limits set forth herein shall apply separately to each insured against whom claims are made or suits are brought, except with respect to the limits of liability.

GENERAL CONDITIONS
SECTION F- LABOR AND CONSTRUCTION

Further the limits set forth herein shall not be construed to relieve the Contractor from liability in excess of such coverage, nor shall it limit Contractor's indemnification obligations to the District, and shall not preclude the District from taking such other actions available to the District under other provisions of the Contract Documents or law.

2. All general liability policies provided pursuant to the provisions of this Article shall comply with the provisions of the Contract Documents.
 3. All general liability policies shall be written to apply to all bodily injury, including death, property damage, personal injury, owned and non-owned equipment, blanket contractual liability, completed operations liability, explosion, collapse, under-ground excavation, removal of lateral support, and other covered loss, however occasioned, occurring during the policy term, and shall specifically insure the performance by Contractor of that part of the indemnification contained in these General Conditions relating to liability for injury to or death of persons and damage to property.
 4. If the coverage contains one or more aggregate limits, a minimum of 50% of any such aggregate limit must remain available at all times; if over 50% of any aggregate limit has been paid or reserved, the District may require additional coverage to be purchased by Contractor to restore the required limits. Contractor may combine primary, umbrella, and as broad as possible excess liability coverage to achieve the total limits indicated above. Any umbrella or excess liability policy shall include the additional insured endorsement described in the Contract Documents.
 5. All policies of general liability insurance shall permit and Contractor does hereby waive any right of subrogation which any insurer of Contractor may acquire from Contractor by virtue of the payment of any loss.
- E. **Automobile Liability Insurance.** Contractor shall provide "occurrence" form Automobile Liability Insurance at least as broad as ISO CA 00 01 (Any Auto) in the amount of, at least, one million dollars (\$1,000,000) per accident for bodily injury and property damage. Such insurance shall provide coverage with respect to the ownership, operation, maintenance, use, loading or unloading of any auto owned, leased, hired or borrowed by Contractor or for which Contractor is responsible, in a form and with insurance companies acceptable to the District. All policies of automobile insurance shall permit and Contractor does hereby waive any right of subrogation which any insurer of Contractor may acquire from Contractor by virtue of the payment of any loss.
1. **Builder's Risk ["All Risk"]** It is the Contractor's responsibility to maintain or cause to be maintained Builder's Risk ["All Risk"] extended coverage insurance on all work, material, equipment, appliances, tools, and structures that are or will become part of the Work and subject to loss or damage by fire, and vandalism and malicious mischief, in an amount to cover 100% of the replacement cost. The District accepts no responsibility for the Work until the Work is formally accepted by the District. The Contractor shall provide a

GENERAL CONDITIONS
SECTION F- LABOR AND CONSTRUCTION

certificate evidencing this coverage before commencing performance of the Work.

2. The named insureds shall be Contractor, all Subcontractors of any tier (excluding those solely responsible for design work), suppliers, and District, its elected officials, officers, employees, agents and authorized volunteers, as their interests may appear. Contractor shall not be required to maintain property insurance for any portion of the Work following acceptance by District.
3. Policy shall be provided for replacement value on an "all risk" basis. There shall be no coinsurance penalty provision in any such policy. Policy must include: (1) coverage for any ensuing loss from faulty workmanship, nonconforming work, omission or deficiency in design or specifications; (2) coverage against machinery accidents and operational testing; (3) coverage for removal of debris, and insuring the buildings, structures, machinery, equipment, materials, facilities, fixtures and all other properties constituting a part of the Project; (4) transit coverage, including ocean marine coverage (unless insured by the supplier), with sub-limits sufficient to insure the full replacement value of any key equipment item; and (5) coverage with sub-limits sufficient to insure the full replacement value of any property or equipment stored either on or off the Site. Such insurance shall be on a form acceptable to District to ensure adequacy and sublimit.
4. In addition, the policy shall meet the following requirements:
 - a. Insurance policies shall be so conditioned as to cover the performance of any extra work performed under the Contract.
 - b. Coverage shall include all materials stored on site and in transit.
 - c. Coverage shall include Contractor's tools and equipment.
 - d. Insurance shall include boiler, machinery and material hoist coverage.
- F. **Contractor's Pollution Liability Coverage.** Contractor shall provide pollution liability insurance in an amount not less than \$1,000,000 per occurrence and \$2,000,000 aggregate.
- G. Contractor shall require all tiers of sub-contractors working under this Contract to provide the insurance required under this Article unless otherwise agreed to in writing by District. Contractor shall make certain that any and all subcontractors hired by Contractor are insured in accordance with this Contract. If any subcontractor's coverage does not comply with the foregoing provisions, Contractor shall indemnify and hold the District harmless from any damage, loss, cost, or expense, including attorneys' fees, incurred by the District as a result thereof.

GENERAL CONDITIONS
SECTION F- LABOR AND CONSTRUCTION

ARTICLE 39 FORM AND PROOF OF CARRIAGE OF INSURANCE

- A. Any insurance carrier providing insurance coverage required by the Contract Documents shall be admitted to and authorized to do business in the State of California unless waived, in writing, by the District's Risk Manager. Carrier(s) shall have an A.M. Best rating of not less than an A:VII. Insurance deductibles or self-insured retentions must be declared by the Contractor. At the election of the District the Contractor shall either 1) reduce or eliminate such deductibles or self-insured retentions, or 2) procure a bond which guarantees payment of losses and related investigations, claims administration, and defense costs and expenses. If umbrella or excess liability coverage is used to meet any required limit(s) specified herein, the Contractor shall provide a "follow form" endorsement satisfactory to the District indicating that such coverage is subject to the same terms and conditions as the underlying liability policy.
- B. Each insurance policy required by this Contract shall be endorsed to state that: (1) coverage shall not be suspended, voided, reduced or cancelled except after thirty (30) days prior written notice by certified mail, return receipt requested, has been given to the District; and (2) any failure to comply with reporting or other provisions of the policies, including breaches of warranties, shall not affect coverage provided to the District, its officials, officers, agents, employees, and volunteers.
- C. The Certificate(s) and policies of insurance shall contain or shall be endorsed to contain the covenant of the insurance carrier(s) that it shall provide no less than thirty (30) days written notice be given to the District prior to any material modification or cancellation of such insurance. In the event of a material modification or cancellation of coverage, the District may terminate the Contract or stop the Work in accordance with the Contract Documents, unless the District receives, prior to such effective date, another properly executed original Certificate of Insurance and original copies of endorsements or certified original policies, including all endorsements and attachments thereto evidencing coverage's set forth herein and the insurance required herein is in full force and effect. Contractor shall not take possession, or use the Site, or commence operations under this Contract until the District has been furnished original Certificate(s) of Insurance and certified original copies of endorsements or policies of insurance including all endorsements and any and all other attachments as required in this Article. The original endorsements for each policy and the Certificate of Insurance shall be signed by an individual authorized by the insurance carrier to do so on its behalf.
- D. The Certificate(s) of Insurance, policies and endorsements shall so covenant and shall be construed as primary, and the District's insurance and/or deductibles and/or self-insured retentions or self-insured programs shall not be construed as contributory.
- E. District reserves the right to adjust the monetary limits of insurance coverages during the term of this Contract including any extension thereof if, in the District's reasonable judgment, the amount or type of insurance carried by the Contractor becomes inadequate.

GENERAL CONDITIONS
SECTION F- LABOR AND CONSTRUCTION

- F. Contractor shall report to the District, in addition to the Contractor's insurer, any and all insurance claims submitted by the Contractor in connection with the Work under this Contract.

ARTICLE 40 TIME FOR COMPLETION AND LIQUIDATED DAMAGES

- A. **Time for Completion/Liquidated Damages.** Time is of the essence in the completion of the Work. Work shall be commenced within ten (10) Days of the date stated in the District's Notice to Proceed and shall be completed by Contractor in the time specified in the Contract Documents. The District is under no obligation to consider early completion of the Project; and the Contract completion date shall not be amended by the District's receipt or acceptance of the Contractor's proposed earlier completion date. Furthermore, Contractor shall not, under any circumstances, receive additional compensation from the District (including but not limited to indirect, general, administrative or other forms of overhead costs) for the period between the time of earlier completion proposed by the Contractor and the Contract completion date. If the Work is not completed as stated in the Contract Documents, it is understood that the District will suffer damage. In accordance with Government Code section 53069.85, being impractical and infeasible to determine the amount of actual damage, it is agreed that Contractor shall pay to the District as fixed and liquidated damages, and not as a penalty, the sum stipulated in the Contract for each calendar day of delay until the Work is fully completed. Contractor and its surety shall be liable for any liquidated damages. Any money due or to become due the Contractor may be retained to cover liquidated damages.
- B. **Inclement Weather.** Contractor shall abide by the Engineer's determination of what constitutes inclement weather. Time extensions for inclement weather shall only be granted when the Work stopped during inclement weather is on the critical path of the Project schedule.
- C. **Extension of Time.** Contractor shall not be charged liquidated damages because of any delays in completion of the Work due to unforeseeable causes beyond the control and without the fault or negligence of Contractor (or its subcontractors or suppliers). Contractor shall within five (5) Days of identifying any such delay notify the District in writing of causes of delay. The District shall ascertain the facts and extent of delay and grant extension of time for completing the Work when, in its judgment, the facts justify such an extension. Time extensions to the Project shall be requested by the Contractor as they occur and without delay. No delay claims shall be permitted unless the event or occurrence delays the completion of the Project beyond the Contract completion date.
- D. **No Damages for Reasonable Delay.** The District's liability to Contractor for delays for which the District is responsible shall be limited to only an extension of time unless such delays were unreasonable under the circumstances. In no case shall the District be liable for any costs which are borne by the Contractor in the regular course of business, including, but not limited to, home office overhead and other ongoing costs. Damages caused by unreasonable District delay, including delays caused by items that are the responsibility of the District

GENERAL CONDITIONS
SECTION F- LABOR AND CONSTRUCTION

pursuant to Government Code section 4215, shall be based on actual costs only, no proportions or formulas shall be used to calculate any delay damages.

ARTICLE 41 COST BREAKDOWN AND INVOICING

Contractor shall furnish on forms Approved by the District:

- A. Within ten (10) Days of Notice to Proceed with the Contract, a detailed estimate giving a complete breakdown of the Contract price, if the Contract amount is a lump sum.
- B. A monthly itemized estimate of Work done for the purpose of making progress payments. In order for the District to consider and evaluate each progress payment application, the Contractor shall submit a detailed measurement of Work performed and a progress estimate of the value thereof before the tenth (10th) Day of the following month.
- C. Contractor shall submit, with each of its payment requests, an adjusted list of actual quantities, verified by the Engineer, for unit price items listed, if any, in the Bid Form.
- D. Following the District's Acceptance of the Work, the Contractor shall submit to the District a written statement of the final quantities of unit price items for inclusion in the final payment request.
- E. The District shall have the right to adjust any estimate of quantity and to subsequently correct any error made in any estimate for payment.

Contractor shall certify under penalty of perjury, that all cost breakdowns and periodic estimates accurately reflect the Work on the Project.

ARTICLE 42 PROGRESS ESTIMATES AND PAYMENT

- A. By the tenth (10th) Day of the following calendar month, Contractor shall submit to Engineer a payment request which shall set forth in detail the value of the Work done for the period beginning with the date work was first commenced and ending on the end of the calendar month for which the payment request is prepared. Contractor shall include any amount earned for authorized extra work. From the total thus computed, a deduction shall be made in the amount of five percent (5%) for retention, except where the District has adopted a finding that the Work done under the Contract is substantially complex, and then the amount withheld as retention shall be the percentage specified in the Notice Inviting Bids. From the remainder a further deduction may be made in accordance with Section B below. The amount computed, less the amount withheld for retention and any amounts withheld as set forth below, shall be the amount of the Contractor's payment request.
- B. The District may withhold a sufficient amount or amounts of any payment or payments otherwise due to Contractor, as in his judgment may be necessary to cover:

GENERAL CONDITIONS
SECTION F- LABOR AND CONSTRUCTION

1. Payments which may be past due and payable for just claims against Contractor or any subcontractors for labor or materials furnished in and about the performance of work on the Project under this Contract.
 2. Defective work not remedied.
 3. Failure of Contractor to make proper payments to his subcontractor or for material or labor.
 4. Completion of the Contract if there is a reasonable doubt that the Work can be completed for balance then unpaid.
 5. Damage to another contractor or a third party.
 6. Amounts which may be due the District for claims against Contractor.
 7. Failure of Contractor to keep the record ("as-built") drawings up to date.
 8. Failure to provide update on construction schedule as required herein.
 9. Site cleanup.
 10. Failure to comply with Contract Documents.
 11. Liquidated damages.
 12. Legally permitted penalties.
- C. The District may apply such withheld amount or amounts to payment of such claims or obligations at its discretion with the exception of subsections (B)(1), (3), and (5) of this Article, which must be retained or applied in accordance with applicable law. In so doing, the District shall be deemed the agent of Contractor and any payment so made by the District shall be considered as a payment made under contract by the District to Contractor and the District shall not be liable to Contractor for such payments made in good faith. Such payments may be made without prior judicial determination of claim or obligations. The District will render Contractor a proper accounting of such funds disbursed on behalf of Contractor.
- D. Upon receipt, the Engineer shall review the payment request to determine whether it is undisputed and suitable for payment. If the payment request is determined to be unsuitable for payment, it shall be returned to Contractor as soon as practicable but not later than seven (7) Days after receipt, accompanied by a document setting forth in writing the reasons why the payment request is not proper. The District shall make the progress payment within 30 calendar days after the receipt of an undisputed and properly submitted payment request from Contractor, provided that a release of liens and claims has been received from the Contractor pursuant to Civil Code section 8132. The number of days available to the District to make a payment without incurring interest pursuant to

GENERAL CONDITIONS
SECTION F- LABOR AND CONSTRUCTION

this paragraph shall be reduced by the number of days by which the Engineer exceeds the seven (7) Day requirement.

- E. A payment request shall be considered properly executed if funds are available for payment of the payment request and payment is not delayed due to an audit inquiry by the financial officer of the District.

ARTICLE 43 SECURITIES FOR MONEY WITHHELD

Pursuant to section 22300 of the Public Contract Code of the State of California, Contractor may request the District to make retention payments directly to an escrow agent or may substitute securities for any money withheld by the District to ensure performance under the contract. At the request and expense of Contractor, securities equivalent to the amount withheld shall be deposited with the District or with a state or federally chartered bank as the escrow agent who shall return such securities to Contractor upon satisfactory completion of the contract. Deposit of securities with an escrow agent shall be subject to a written agreement substantially in the form provided in section 22300 of the Public Contract Code.

ARTICLE 44 CHANGES AND EXTRA WORK.

A. Contract Change Orders.

1. The District, without invalidating the Contract, may order changes in the Work consisting of additions, deletions or other revisions, and the Contract Price and Contract Time shall be adjusted accordingly. Except as otherwise provided herein, all such changes in the Work shall be authorized by Change Order, and shall be performed under the applicable conditions of the Contract Documents. A Change Order signed by the Contractor indicates the Contractor's agreement therewith, including any adjustment in the Contract Price or the Contract Time, and the full and final settlement of all costs (direct, indirect and overhead) related to the Work authorized by the Change Order.
2. Contractor shall promptly execute changes in the Work as directed in writing by the District even when the parties have not reached agreement on whether the change increases the scope of Work or affects the Contract Price or Contract Time. All claims for additional compensation to the Contractor shall be presented in writing. No claim will be considered after the Work in question has been done unless a written Change Order has been issued or a timely written notice of claim has been made by Contractor.
3. Whenever any change is made as provided for herein, such change shall be considered and treated as though originally included in the Contract, and shall be subject to all terms, conditions, and provisions of the original Contract.
4. Contractor shall not be entitled to claim or bring suit for damages, whether for loss of profits or otherwise, on account of any decrease or omission of any item or portion of Work to be done.

GENERAL CONDITIONS
SECTION F- LABOR AND CONSTRUCTION

5. No dispute, disagreement, or failure of the parties to reach agreement on the terms of the Change Order shall relieve the Contractor from the obligation to proceed with performance of the work, including Additional Work, promptly and expeditiously.
6. Contractor shall make available to the District any of the Contractor's documents related to the Project immediately upon request of the District, as set forth in Article 52.
7. Any alterations, extensions of time, Additional Work, or any other changes may be made without securing consent of the Contractor's surety or sureties.

B. Contract Price Change.

1. Process for Determining Adjustments in Contract Price.
 - a. Owner Initiated Change. The Contractor must submit a complete cost proposal, including any change in the Contract Price or Contract Time, within seven (7) Days after receipt of a scope of a proposed change order initiated by the District, unless the District requests that proposals be submitted in less than seven (7) Days.
 - b. Contractor Initiated Change. The Contractor must give written notice of a proposed change order required for compliance with the Contract Documents within seven (7) Days of discovery of the facts giving rise to the proposed change order.
 - c. Whenever possible, any changes to the Contract amount shall be in a lump sum mutually agreed to by the Contractor and the District.
 - d. Price quotations from the Contractor shall be accompanied by sufficiently detailed supporting documentation to permit verification by the District, including but not limited to estimates and quotations from subcontractors or material suppliers, as the District may reasonably request. Contractor shall certify the accuracy of all Change Order Requests under penalty of perjury.
 - e. If the Contractor fails to submit a complete cost proposal within the seven (7) Day period (or as requested), the District has the right to order the Contractor in writing to commence the Work immediately on a time and materials basis and/or issue a lump sum change to the Contract Price and/or Contract Time in accordance with the District's estimate. If the change is issued based on the District's estimate, the Contractor will waive its right to dispute the action unless within fifteen (15) Days following completion of the added/deleted work, the Contractor presents written proof that the District's estimate was in error.
2. Unit Price Change Orders.
 - a. When the actual quantity of a Unit Price item varies from the Bid Form, compensation for the change in quantity will be calculated by multiplying the

GENERAL CONDITIONS
SECTION F- LABOR AND CONSTRUCTION

actual quantity by the Unit Price. This calculation may result in either an additive or deductive Final Change Order pursuant to the Contract Documents.

- b. No Mark up for Overhead and Profit. Because the Contract Unit Prices provided in the Bid Form include Overhead and Profit as determined by Contractor at the time of Bid submission, no mark up or deduction for Overhead and Profit will be included in Unit Price Change Orders.
 - c. Bid items included on the Bid Form may be deducted from the Work in their entirety without any negotiated extra costs.
 - d. Contractor acknowledges that unit quantities are estimates and agrees that the estimated unit quantities listed on the Bid Form will be adjusted to reflect the actual unit quantities which may result in an adjustment to the Contract Unit Prices. Such an adjustment will be made by execution of a final additive or deductive Change Order following Contractor's completion of the Work. Upon notification, Contractor's failure to respond within seven (7) Days will result in District's issuance of a unit quantity adjustment to the Contract Unit Prices and/or Contract Time in accordance with the Contract Documents.
 - e. The District or Contractor may make a Claim for an adjustment in the Unit Price in accordance with the Contract Documents if:
 - i. the quantity of any item of Unit Price Work performed by Contractor differs by twenty-five percent (25%) or more from the estimated quantity of such item indicated in the Contract; and
 - ii. there is no corresponding adjustment with respect to any other item of Work; and
 - iii. Contractor believes that Contractor is entitled to an increase in Unit Price as a result of having incurred additional expense or the District believes that the District is entitled to a decrease in Unit Price and the parties are unable to agree as to the amount of any such increase or decrease..
3. Lump Sum Change Orders. Compensation for Lump Sum Change Orders shall be limited to expenditures necessitated specifically by the Additional Work, and shall be segregated as follows:
- a. Labor. The costs of labor will be the actual cost for wages prevailing locally for each craft or type of worker at the time the Additional Work is done, plus employer payments of payroll taxes and insurance, health and welfare, pension, vacation, apprenticeship funds, and other direct costs resulting from Federal, State or local laws, as well as assessment or benefits required by lawful collective bargaining agreements. The use of a labor classification which would increase the Additional Work cost will not be permitted unless the Contractor establishes the necessity for such new classifications. Labor costs for equipment operators and helpers shall be reported only when such costs are not included in the invoice for equipment rental.

GENERAL CONDITIONS
SECTION F- LABOR AND CONSTRUCTION

- b. Materials. The cost of materials reported shall be at invoice or lowest current price at which such materials are locally available in the quantities involved, plus sales tax, freight, and delivery. Materials costs shall be based upon supplier or manufacturer's invoice. If invoices or other satisfactory evidence of cost are not furnished within fifteen (15) Days of delivery, then the District shall determine the materials cost, at its sole discretion.
 - c. Tool and Equipment Use. Costs for the use of small tools, which are tools that have a replacement value of \$1,000 or less, shall be considered included in the Overhead and Profit mark-ups established below. Regardless of ownership, the rates to be used in determining equipment use costs shall not exceed listed rates prevailing locally at equipment rental agencies, or distributors, at the time the Work is performed.
4. Time and Materials Change Orders.
- a. General. The term Time and Materials means the sum of all costs reasonably and necessarily incurred and paid by Contractor for labor, materials, and equipment in the proper performance of Additional Work. Except as otherwise may be agreed to in writing by the District, such costs shall be in amounts no higher than those prevailing in the locality of the Project, and shall include only the following items.
 - b. Timely and Final Documentation.
 - i. T&M Daily Sheets. Contractor must submit timesheets, materials invoices, records of equipment hours, and records of rental equipment hours to the District's Representative for an approval signature **each day** Additional Work is performed. Failure to get the District's Representative's approval signature each Day shall result in a waiver of Contractor's right to claim these costs. The District's Representative's signature on time sheets only serves as verification that the Work was performed and is not indicative of District's agreement to Contractor's entitlement to the cost.
 - ii. T&M Daily Summary Sheets. All documentation of incurred costs ("T&M Daily Summary Sheets") shall be submitted by Contractor within **three (3) Days** of incurring the cost for labor, material, equipment, and special services as Additional Work is performed. Contractor's actual costs shall be presented in a summary table in an electronic spreadsheet file by labor, material, equipment, and special services. Each T&M Daily Summary Sheet shall include Contractor's actual costs incurred for the Additional Work performed that day and a cumulative total of Contractor's actual costs incurred for the Additional Work. Contractor's failure to provide a T&M Daily Summary Sheet showing a total cost summary within three (3) Days but within five (5) Days of performance of the Work will result in the Contractor's otherwise allowable overhead and profit being reduced by 50% for that portion of Additional Work which was not documented in a timely manner. Contractor's failure to submit the T&M Daily Summary Sheet

GENERAL CONDITIONS
SECTION F- LABOR AND CONSTRUCTION

within five (5) Days of performance of the Work will result in a total waiver of Contractor's right to claim these costs.

- iii. T&M Total Cost Summary Sheet. Contractor shall submit a T&M Total Cost Summary Sheet, which shall include total actual costs, within **seven (7) Days** following completion of District approved Additional Work. Contractor's total actual cost shall be presented in a summary table in an electronic spreadsheet file by labor, material, equipment, and special services. Contractor's failure to submit the T&M Total Cost Summary Sheet within seven (7) Days of completion of the Additional Work will result in Contractor's waiver for any reimbursement of any costs associated with the T&M Summary Sheets or the performance of the Additional Work.
 - iv. Labor. The Contractor will be paid the cost of labor for the workers used in the actual and direct performance of the Work. The cost of labor will be the sum of the actual wages paid (which shall include any employer payments to or on behalf of the workers for health and welfare, pension, vacation, and similar purposes) substantiated by timesheets and certified payroll for wages prevailing for each craft or type of workers performing the Additional Work at the time the Additional Work is done, and the labor surcharge set forth in the Department of Transportation publication entitled *Labor Surcharge and Equipment Rental Rates*, which is in effect on the date upon which the Work is accomplished and which is a part of the Contract. The labor surcharge shall constitute full compensation for all payments imposed by Federal, State, or local laws and for all other payments made to, or on behalf of, the workers, other than actual wages.
 - v. Equipment Operator Exception. Labor costs for equipment operators and helpers shall be paid only when such costs are not included in the invoice for equipment rental.
 - vi. Foreman Exception. The labor costs for foremen shall be proportioned to all of their assigned work and only that applicable to the Additional Work shall be paid. Indirect labor costs, including, without limitation, the superintendent, project manager, and other labor identified in the Contract Documents will be considered Overhead.
- C. Materials. The cost of materials reported shall be itemized at invoice or lowest current price at which materials are locally available and delivered to the Project site in the quantities involved, plus the cost of sales tax, freight, delivery, and storage.
- 1. Trade discounts available to the purchaser shall be credited to the District notwithstanding the fact that such discounts may not have been taken by Contractor.

GENERAL CONDITIONS
SECTION F- LABOR AND CONSTRUCTION

2. For materials secured by other than a direct purchase and direct billing to the purchaser, the cost shall be deemed to be the price paid to the actual supplier as determined by the District's Representative.
3. Payment for materials from sources owned wholly or in part by the purchaser shall not exceed the price paid by the purchaser for similar materials from said sources on Additional Work items or the current wholesale price for such materials delivered to the Project site, whichever price is lower.
4. If, in the opinion of the District's Representative, the cost of materials is excessive, or Contractor does not furnish satisfactory evidence of the cost of such materials, then the cost shall be deemed to be the lowest current wholesale price for the total quantity concerned delivered to the Project site less trade discounts.
5. The District reserves the right to furnish materials for the Additional Work and no Claim shall be allowed by Contractor for costs of such materials or Indirect Costs or profit on District furnished materials.

D. Equipment.

1. Rental Time. The rental time to be paid for equipment on the Project site shall be the time the equipment is in productive operation on the Additional Work being performed and, in addition, shall include the time required to move the equipment to the location of the Additional Work and return it to the original location or to another location requiring no more time than that required to return it to its original location; except that moving time will not be paid if the equipment is used on other than the Additional Work, even though located at the site of the Additional Work.
 - (a) Rental Time Not Allowed. Rental time will not be allowed while equipment is inoperative due to breakdowns.
 - (b) Computation Method. The following shall be used in computing the rental time of equipment on the Project site.
 - (i) When hourly rates are paid, any part of an hour less than 30 minutes of operation shall be considered to be 1/2-hour of operation, and any part of an hour in excess of 30 minutes will be considered one hour of operation.
 - (ii) When daily rates are paid, any part of a day less than 4 hours operation shall be considered to be 1/2-day of operation, and any part of an hour in excess of 4 hours will be considered one day of operation.
2. Rental Rates. Contractor will be paid for the use of equipment at the lesser of (i) the actual rental rate, or (ii) the rental rate listed for that equipment in the California Department of Transportation publication

GENERAL CONDITIONS
SECTION F- LABOR AND CONSTRUCTION

entitled *Labor Surcharge and Equipment Rental Rates*, which is in effect on the date upon which the Contract was executed. Such rental rates will be used to compute payments for equipment whether the equipment is under Contractor's control through direct ownership, leasing, renting, or another method of acquisition. The rental rate to be applied for use of each item of equipment shall be the rate (i.e., daily, monthly) resulting in the least total cost to the District for the total period of use. If it is deemed necessary by Contractor to use equipment not listed in the publication, an equitable rental rate for the equipment will be established by the District's Representative. Contractor may furnish cost data which might assist the District's Representative in the establishment of the rental rate.

E. Contractor-Owned Equipment.

1. For Contractor-owned equipment, the allowed equipment rental rate will be limited to the monthly equipment rental rate using a utilization rate of 173 hours per month.
2. (b) For Contractor-owned equipment, the rental time to be paid for equipment on the Site shall be the time the equipment is in productive operation, unless, in the instance of standby time, the equipment could be actively used by Contractor on another project, then District shall pay for the entirety of the time the equipment is on Site. It shall be Contractor's burden to demonstrate to the District that the equipment could be actively used on another project.
 - a. All equipment shall, in the opinion of the District's Representative, be in good working condition and suitable for the purpose for which the equipment is to be used.
 - b. Before construction equipment is used on the Additional Work, Contractor shall plainly stencil or stamp an identifying number thereon at a conspicuous location, and shall furnish to the District's Representative, in duplicate, a description of the equipment and its identifying number and the scheduled Additional Work activities planned.
 - c. Unless otherwise specified, manufacturer's rating and manufacturer approved modifications shall be used to classify equipment for the determination of applicable rental rates. Equipment which has no direct power unit shall be powered by a unit of at least the minimum rating recommended by the manufacturer.

- F. Special Services. Special work or services are defined as that Additional Work characterized by extraordinary complexity, sophistication, or innovation or a combination of the foregoing attributes which are unique to the construction industry.

GENERAL CONDITIONS
SECTION F- LABOR AND CONSTRUCTION

- G. Invoices for Special Services. When the District's Representative and Contractor determine that a special service is required which cannot be performed by the forces of Contractor or those of any of its Subcontractors, the special service may be performed by an entity especially skilled in the Additional Work. Invoices for special services based upon the current fair market value thereof may be accepted without complete itemization of labor, material, and equipment rental costs, after validation of market values by the District's Representative.
- H. Discount and Allowance. All invoices for special services will be adjusted by deducting all trade discounts offered or available, whether the discounts were taken or not. In lieu of Overhead and Profit specified herein, a total allowance not to exceed fifteen percent (15%) for Overhead and Profit will be added to invoices for Special Services.
- a. When the District determines, in its sole discretion, that competitive bidding is necessary for certain special services, Contractor shall solicit competitive bids for those special services.
- I. Excluded Costs. The term Time and Material shall not include any of the following costs or any other home or field office overhead costs, all of which are to be considered administrative costs covered by Contractor's allowance for Overhead and Profit.
1. Overhead Cost. Payroll costs and other compensation of Contractor's officers, executives, principals, general managers, engineers, architects, estimators, attorneys, auditors, accountants, purchasing and contracting agents, timekeepers, clerks, and other personnel employed by Contractor whether at the Site or in Contractor's principal office or any branch office, material yard, or shop for general administration of the Additional Work;
 2. Office Expenses. Expenses of Contractor's principal and branch offices;
 3. Capital Expenses. Any part of Contractor's capital expenses, including interest on Contractor's capital employed for the Additional Work and charges against Contractor for delinquent payments;
 4. Negligence. Costs due to the negligence of Contractor or any Subcontractor or Supplier, or anyone directly or indirectly employed by any of them or for whose acts any of them may be liable, including without limitation the correction of Defective Work, disposal of materials or equipment wrongly supplied, and making good any damage to property;
 5. Other. Other overhead or general expense costs of any kind and the cost of any item not specifically and expressly included in the Contract Documents;

GENERAL CONDITIONS
SECTION F- LABOR AND CONSTRUCTION

6. Small Tools. Cost of small tools valued at less than \$1,000 and that remain the property of Contractor;
 7. Administrative Costs. Costs associated with the preparation of Change Orders (whether or not ultimately authorized), cost estimates, or the preparation or filing of Claims;
 8. Anticipated Lost Profits. Expenses of Contractor associated with anticipated lost profits or lost revenues, lost income or earnings, lost interest on earnings, or unpaid retention;
 9. Home Office Overhead. Costs derived from the computation of a "home office overhead" rate by application of the *Eichleay, Allegheny*, burden fluctuation, or other similar methods;
 10. Special Consultants and Attorneys. Costs of special consultants or attorneys, whether or not in the direct employ of Contractor, employed for services specifically related to the resolution of a Claim, dispute, or other matter arising out of or relating to the performance of the Additional Work.
- J. Overhead, Profit and Other Charges. The mark-up for overhead (including supervision) and profit on work added to the Contract shall be according to the following:
1. "Net Cost" is defined as consisting of costs of labor, materials, and tools and equipment only excluding overhead and profit. The costs of applicable insurance and bond premium will be reimbursed to the Contractor and subcontractors at cost only, without mark-up. Contractor shall provide District with documentation of the costs, including, but not limited to, payroll records, invoices, and such other information as District may reasonably request.
 2. For Work performed by the Contractor's forces, the added cost for overhead and profit shall not exceed fifteen percent (15%) of the Net Cost of the Work.
 3. For Work performed by a subcontractor, the added cost for overhead and profit shall not exceed fifteen percent (15%) of the subcontractor's Net Cost of the Work to which the Contractor may add five percent (5%) of the subcontractor's Net Cost.
 4. For Work performed by a sub-subcontractor, the added cost for overhead and profit shall not exceed fifteen percent (15%) of the sub-subcontractor's Net Cost for Work to which the subcontractor and general contractor may each add an additional five percent (5%) of the Net Cost of the lower tier subcontractor.
 5. No additional mark-up will be allowed for lower tier subcontractors, and in no case shall the added cost for overhead and profit payable

GENERAL CONDITIONS
SECTION F- LABOR AND CONSTRUCTION

by District exceed twenty-five percent (25%) of the Net Cost as defined herein, of the party that performs the Work.

6. All of the following costs are included in the markups for overhead and profit described above, and Contractor shall not receive any additional compensation for: Submittals, drawings, field drawings, Shop Drawings, including submissions of drawings; field inspection; General Superintendence; General administration and preparation of cost proposals, schedule analysis, Change Orders, and other supporting documentation; computer services; reproduction services; Salaries of project engineer, superintendent, timekeeper, storekeeper, and secretaries; Janitorial services; Small tools, incidentals and consumables; Temporary On-Site facilities (Offices, Telephones, High Speed Internet Access, Plumbing, Electrical Power, Lighting; Platforms, Fencing, Water), Jobsite and Home office overhead or other expenses; vehicles and fuel used for work otherwise included in the Contract Documents; Surveying; Estimating; Protection of Work; Handling and disposal fees; Final Cleanup; Other Incidental Work; Related Warranties; insurance and bond premiums.
7. For added or deducted Work by subcontractors, the Contractor shall furnish to the District the subcontractor's signed detailed record of the cost of labor, material and equipment, including the subcontractor markup for overhead and profit. The same requirement shall apply to sub-subcontractors
8. For added or deducted work furnished by a vendor or supplier, the Contractor shall furnish to the District a detailed record of the cost to the Contractor, signed by such vendor or supplier.
9. Any change in the Work involving both additions and deletions shall indicate a net total cost, including subcontracts and materials. Allowance for overhead and profit, as specified herein, shall be applied if the net total cost is an increase in the Contract Price; overhead and profit allowances shall not be applied if the net total cost is a deduction to the Contract Price. The estimated cost of deductions shall be based on labor and material prices on the date the Contract was executed.
10. Contractor shall not reserve a right to assert impact costs, extended job site costs, extended overhead, constructive acceleration and/or actual acceleration beyond what is stated in the Change Order for Work. No claims shall be allowed for impact, extended overhead costs, constructive acceleration and/or actual acceleration due to a multiplicity of changes and/or clarifications. The Contractor may not change or modify the District's change order form in an attempt to reserve additional rights.
11. If the District disagrees with the proposal submitted by Contractor, it will notify the Contractor and the District will provide its opinion of the

GENERAL CONDITIONS
SECTION F- LABOR AND CONSTRUCTION

appropriate price and/or time extension. If the Contractor agrees with the District, a Change Order will be issued by the District. If no agreement can be reached, the District shall have the right to issue a unilateral Change Order setting forth its determination of the reasonable additions or savings in costs and time attributable to the extra or deleted work. Such determination shall become final and binding if the Contractor fails to submit a claim in writing to the District within fifteen (15) Days of the issuance of the unilateral Change Order, disputing the terms of the unilateral Change Order, and providing such supporting documentation for its position as the District may require.

K. Change of Contract Times.

1. The Contract Times may only be changed by a Change Order.
2. All changes in the Contract Price and/or adjustments to the Contract Times related to each change shall be included in Contractor's COR pursuant to this Article. No cost or time will be allowed for cumulative effects of multiple changes. All Change Orders must state that the Contract Time is not changed or is either increased or decreased by a specific number of days. Failure to include a change to time shall waive any change to the time unless the parties mutually agree in writing to postpone a determination of the change to time resulting from the Change Order.
3. Notice of the amount of the request for adjustment in the Contract Times with supporting data shall be delivered within seven (7) Days after such start of occurrence, unless District's Representative allows an additional period of time to ascertain more accurate data in support of the request. No extension of time or additional compensation shall be given for a delay if the Contractor failed to give notice in the manner and within the time prescribed.
4. District may elect, at District's sole discretion, to grant an extension in Contract Times, without Contractor's request, because of delays or other factors.

L. Use of Float and Critical Path.

1. Float is for the benefit of the Project. Float shall not be considered for the exclusive use or benefit of either the District or the Contractor.
2. Contractor shall not be entitled to compensation, and District will not compensate Contractor, for delays which impact early completion. Any difference in time between the Contractor's early completion and the Contract Time shall be considered a part of the Project float.
3. Contractor's entitlement to an extension of the Contract Times is limited to a District-caused extension of the critical path, reduced by the Contractor's concurrent delays, and established by a proper time impact analysis. No time extension shall be allowed unless, and then only to the extent that, the District-caused delay extends the critical path beyond the

GENERAL CONDITIONS
SECTION F- LABOR AND CONSTRUCTION

previously approved Contract Time. If approved, the increase in time required to complete the Work shall be added to the Contract Time.

4. Contractor shall not be entitled to an adjustment in the Contract Price or Contract Times for delays within the control of Contractor. Delays attributable to and within the control of a Subcontractor or Supplier shall be deemed to be delays within the control of Contractor.
5. If Contractor is delayed in the performance or progress of the Work by fire, flood, epidemic, abnormal weather conditions (as determined by the District), Acts of God, acts or failures to act of utility owners not under the control of District, or other causes not the fault of and beyond control of District and Contractor, then Contractor shall be entitled to a time extension when the Work stopped is on the critical path. Such a non-compensable adjustment shall be Contractor's sole and exclusive remedy for such delays. Contractor must submit a timely request in accordance with the requirements of this Article.

M. Utility-Related Delays.

1. Contractor shall immediately notify in writing the utility owner and District's Representative of its construction schedule and any subsequent changes in the construction schedule which will affect the time available for protection, removal, or relocation of utilities. Requests for extensions of time arising out of utility relocation or repair delays shall be filed in accordance with this Article.
2. Contractor shall not be entitled to damages or additional payment for delays attributable to utility relocations or alterations if correctly located, as noted in the Contract Documents or by the Underground Service Alert survey.

N. Content for Requests for Contract Extension. Contractor's justification for entitlement shall be clear and complete citing specific Contract Document references and reasons on which Contractor's entitlement is based. At a minimum, each request for a time extension must include:

1. Each request for an extension of Contract Time must identify the impacting event, in narrative form, providing a description of the delay event and sufficient justification as to why the Contractor is entitled to a time extension. Contractor must demonstrate that the delay arises from unforeseeable causes beyond the control and without the fault or negligence of both Contractor and any Subcontractors or Suppliers, or any other persons or organizations employed by any of them or for whose acts any of them may be liable, and that such causes in fact lead to performance or completion of the Work, or specified part in question, beyond the corresponding Contract Times, despite Contractor's reasonable and diligent actions to guard against those effects.

GENERAL CONDITIONS
SECTION F- LABOR AND CONSTRUCTION

2. Each request for an extension of Contract Time must include a time impact analysis in CPM format, using the Contemporaneous Impacted As-Planned Schedule Analysis to calculate the impact of the delay event.

O. No Damages for Reasonable Delay.

1. District's liability to Contractor for delays for which District is responsible shall be limited to only an extension of time unless such delays were unreasonable under the circumstances. In no case shall District be liable for any costs which are borne by the Contractor in the regular course of business, including, but not limited to, home office overhead and other ongoing costs.
2. Damages caused by unreasonable District delay that impact the critical path, including delays caused by items that are the responsibility of the District pursuant to Government Code section 4215, shall be compensated at the Daily Rate established in the Special Conditions. No other calculations, proportions or formulas shall be used to calculate any delay damages.
3. District and District's Representative, and the officers, members, partners, employees, agents, consultants, or subcontractors of each of them, shall not be liable to Contractor for any claims, costs, losses, or damages (including but not limited to all fees and charges of engineers, architects, attorneys, and other professionals and all court or arbitration or other dispute resolution costs) sustained by Contractor on or in connection with any other project or anticipated project.
4. Contractor's failure, neglect, or refusal to comply with the requirements of the Contract Documents, or any portion thereof, shall bar Contractor's request for extensions of the Contract Times. Such failure, neglect, or refusal prejudices District's and District's Representative's ability to recognize and mitigate delay, and such failure, neglect, or refusal prevent the timely analysis of requests for extensions of Contract Times, and whether such extensions may be warranted. Contractor hereby waives all rights to extensions of Contract Times due to delays or accelerations that result from or occur during periods of time for which Contractor fails, neglects, or refuses to fully comply with the requirements of this Article.

ARTICLE 45 FINAL ACCEPTANCE AND PAYMENT

- A. The acceptance of the Work on behalf of the District will be made by the Engineer. Such acceptance by the District shall not constitute a waiver of defects. When the Work has been accepted there shall be paid to Contractor a sum equal to the contract price less any amounts previously paid Contractor and less any amounts withheld by the District from Contractor under the terms of the contract. The final five percent (5%), or the percentage specified in the notice inviting bids where the District has adopted a finding of substantially complete, shall not become due and payable until five (5) calendar days shall have elapsed after the expiration of the period within which all claims may be filed

GENERAL CONDITIONS
SECTION F- LABOR AND CONSTRUCTION

under the provisions of Civil Code section 9356. If the Contractor has placed securities with the District as described herein, the Contractor shall be paid a sum equal to one hundred percent (100%) of the contract price less any amounts due the District under the terms of the Contract.

- B. Unless Contractor advises the District in writing prior to acceptance of the final five percent (5%) or the percentage specified in the notice inviting bids where the District has adopted a finding of substantially complete, or the return of securities held as described herein, said acceptance shall operate as a release to the District of all claims and all liability to Contractor for all things done or furnished in connection with this work and for every act of negligence of the District and for all other claims relating to or arising out of this work. If Contractor advises the District in writing prior to acceptance of final payment or return of the securities that there is a dispute regarding the amount due the Contractor, the District may pay the undisputed amount contingent upon the Contractor furnishing a release of all undisputed claims against the District with the disputed claims in stated amounts being specifically excluded by Contractor from the operation of the release. No payments, however, final or otherwise, shall operate to release Contractor or its sureties from the Faithful Performance Bond, Labor and Material Payment Bond, or from any other obligation under this contract.
- C. In case of suspension of the contract any unpaid balance shall be and become the sole and absolute property of the District to the extent necessary to repay the District any excess in the cost of the Work above the contract price.
- D. Final payment shall be made no later than 60 days after the date of acceptance of the Work by the District or the date of occupation, beneficial use and enjoyment of the Work by the District including any operation only for testing, start-up or commissioning accompanied by cessation of labor on the Work, provided that a release of liens and claims has been received from the Contractor pursuant to Civil Code section 8136. In the event of a dispute between the District and the Contractor, the District may withhold from the final payment an amount not to exceed 150% of the disputed amount.
- E. Within ten (10) calendar days from the time that all or any portion of the retention proceeds are received by Contractor, Contractor shall pay each of its subcontractors from whom retention has been withheld each subcontractor's share of the retention received. However, if a retention payment received by Contractor is specifically designated for a particular subcontractor, payment of the retention shall be made to the designated subcontractor if the payment is consistent with the terms of the subcontract.

ARTICLE 46 OCCUPANCY

The District reserves the right to occupy or utilize any portion of the Work at any time before completion, and such occupancy or use shall not constitute acceptance of any part of Work covered by this Contract. This use shall not relieve the Contractor of its responsibilities under the Contract.

GENERAL CONDITIONS
SECTION F- LABOR AND CONSTRUCTION

ARTICLE 47 INDEMNIFICATION

To the fullest extent permitted by law, Contractor shall immediately defend (with counsel of the District's choosing), indemnify and hold harmless the District, officials, officers, agents, employees, and representatives, and each of them from and against:

- A. Any and all claims, demands, causes of action, costs, expenses, injuries, losses or liabilities, in law or in equity, of every kind or nature whatsoever, but not limited to, injury to or death, including wrongful death, of any person, and damages to or destruction of property of any person, arising out of, related to, or in any manner directly or indirectly connected with the Work or this Contract, including claims made by subcontractors for nonpayment, including without limitation the payment of all consequential damages and attorney's fees and other related costs and expenses, however caused, regardless of whether the allegations are false, fraudulent, or groundless, and regardless of any negligence of the District or its officers, employees, or authorized volunteers (including passive negligence), except the sole negligence or willful misconduct or active negligence of the District or its officials, officers, employees, or authorized volunteers.
- B. Contractor's defense and indemnity obligation herein includes, but is not limited to damages, fines, penalties, attorney's fees and costs arising from claims under the Americans with Disabilities Act (ADA) or other federal or state disability access or discrimination laws arising from Contractor's Work during the course of construction of the improvements or after the Work is complete, as the result of defects or negligence in Contractor's construction of the improvements.
- C. Any and all actions, proceedings, damages, costs, expenses, fines, penalties or liabilities, in law or equity, of every kind or nature whatsoever, arising out of, resulting from, or on account of the violation of any governmental law or regulation, compliance with which is the responsibility of Contractor;
- D. Any and all losses, expenses, damages (including damages to the Work itself), attorney's fees, and other costs, including all costs of defense which any of them may incur with respect to the failure, neglect, or refusal of Contractor to faithfully perform the Work and all of Contractor's obligations under the agreement. Such costs, expenses, and damages shall include all costs, including attorney's fees, incurred by the indemnified parties in any lawsuit to which they are a party.

Contractor shall immediately defend, at Contractor's own cost, expense and risk, with the District Board's choosing, any and all such aforesaid suits, actions or other legal proceedings of every kind that may be brought or instituted against the District, its officials, officers, agents, employees and representatives. Contractor shall pay and satisfy any judgment, award or decree that may be rendered against the District, its officials, officers, employees, agents, employees and representatives, in any such suit, action or other legal proceeding. Contractor shall reimburse the District, its officials, officers, agents, employees and representatives for any and all legal expenses and costs incurred by each of them in connection therewith or in enforcing the indemnity herein provided. The only limitations on this provision shall be those imposed by Civil Code section 2782.

GENERAL CONDITIONS
SECTION F- LABOR AND CONSTRUCTION

ARTICLE 48 PROCEDURE FOR RESOLVING DISPUTES

In accordance with Public Contract Code sections 20104 *et seq.* and other applicable law, public works claims of \$375,000 or less which arise between the Contractor and the District shall be resolved under the following statutory procedure unless the District has elected to resolve the dispute pursuant to Public Contract Code section 10240 *et seq.*

- A. **All Claims.** All claims shall be submitted in writing and accompanied by substantiating documentation. Claims must be filed on or before the date of final payment unless other notice requirements are provided in the contract. "Claim" means a separate demand by the Contractor for (1) a time extension, (2) payment of money or damages arising from work done by or on behalf of the Contractor and payment of which is not otherwise expressly provided for or the Contractor is not otherwise entitled, or (3) an amount the payment of which is disputed by the District.

- B. **Claims Under \$50,000.** The District shall respond in writing to the claim within 45 calendar days of receipt of the claim, or, the District may request, in writing, within 30 calendar days of receipt of the claim, any additional documentation supporting the claim or relating to defenses or claims the District may have. If additional information is needed thereafter, it shall be provided upon mutual agreement of the District and the Contractor. The District's written response shall be submitted 15 calendar days after receiving the additional documentation, or within the same period of time taken by the Contractor to produce the additional information, whichever is greater.

- C. **Claims over \$50,000 but less than or equal to \$375,000.** The District shall respond in writing within 60 calendar days of receipt, or, may request in writing within 30 calendar days of receipt of the claim, any additional documents supporting the claim or relating to defenses or claims the District may have against the District. If additional information is needed thereafter, it shall be provided pursuant to mutual agreement between the District and the Contractor. The District response shall be submitted within 30 calendar days after receipt of the further documents, or within the same period of time taken by the Contractor to produce the additional information or documents, whichever is greater. The Contractor shall make these records and documents available at all reasonable times, without any direct charge.

- D. **All Claims.** The Contractor will submit the claim justification in the following format:
 - 1. Summary of claim merit and price, and Contract clause pursuant to which the claim is made.
 - 2. List of documents relating to claim:
 - a. Specifications
 - b. Drawings
 - c. Clarifications (Requests for Information)
 - d. Schedules

GENERAL CONDITIONS
SECTION F- LABOR AND CONSTRUCTION

e. Other (All Related Documents)

3. Chronology of events and correspondence.
4. Analysis of claim merit.
5. Analysis of claim cost.
6. Analysis of time impact analysis in CPM format.
7. Cover letter and certification of validity of the claim.

E. **All Claims.** If the Contractor disputes the District's response, or if the District fails to respond within the statutory time period(s), the Contractor may so notify the District within 15 calendar days of the receipt of the response or the failure to respond, and demand an informal conference to meet and confer for settlement. Upon such demand, the District shall schedule a meet and confer conference within 30 calendar days.

F. The Contractor must comply with the claims filing procedures set forth in Government Code sections 900 *et seq.* for any claim or any portion thereof that remains in dispute, after the meet and confer conference. For purposes of those provisions, the time within which a claim must be filed shall be tolled from the time the Contractor submits the written claim until the time the claim is denied, including any time utilized for the meet and confer conference. Submission of a claim, properly certified, with all required supporting documentation, and written rejection or denial of all or part of the claim by the District, is a condition precedent to any action, proceeding, litigation, suit, general conditions claim, or demand for arbitration by Contractor.

G. **Government Code Claim.** In addition to any and all contract requirements pertaining to notices of and requests for compensation or payment for extra work, disputed work, construction claims and/or changed conditions, the Contractor must comply with the claim procedures set forth in Government Code sections 900 *et seq.* prior to filing any lawsuit against the District. Such Government Code claims and any subsequent lawsuit based upon the Government Code claims shall be limited to those matters that remain unresolved after all procedures pertaining to extra work, disputed work, construction claims, and/or changed conditions have been followed by Contractor. If no such Government Code claim is submitted, or if the prerequisite contractual requirements are not otherwise satisfied as specified herein, Contractor shall be barred from bringing and maintaining a valid lawsuit against the District.

ARTICLE 49 DISTRICT'S RIGHT TO TERMINATE CONTRACT

A. Termination for Cause by the District:

1. In the sole estimation of the District, if the Contractor refuses or fails to prosecute the Work or any separable part thereof with such diligence as will

GENERAL CONDITIONS
SECTION F- LABOR AND CONSTRUCTION

insure its completion within the time specified by the Contract Documents, or any extension thereof, or fails to complete such Work within such time, or if the Contractor should be adjudged a bankrupt, or if it should make a general assignment for the benefit of its creditors, or if a receiver should be appointed on account of its insolvency, or the Contractor or any of its subcontractors should violate any of the provisions of this Contract, the District may serve written notice upon the Contractor and its Surety of the District's intention to terminate this Contract. This notice of intent to terminate shall contain the reasons for such intention to terminate this Contract, and a statement to the effect that the Contractor's right to perform this Contract shall cease and terminate upon the expiration of ten (10) calendar days unless such violations have ceased and arrangements satisfactory to the District have been made for correction of said violations.

2. In the event that the District serves such written notice of termination upon the Contractor and the Surety, the Surety shall have the right to take over and perform the Contract. If the Surety does not: (1) give the District written notice of Surety's intention to take over and commence performance of the Contract within 15 calendar days of the District's service of said notice of intent to terminate upon Surety; and (2) actually commence performance of the Contract within 30 calendar days of the District's service of said notice upon Surety; then the District may take over the Work and prosecute the same to completion by separate contract or by any other method it may deem advisable for the account and at the expense of the Contractor.
3. In the event that the District elects to obtain an alternative performance of the Contract as specified above: (1) the District may, without liability for so doing, take possession of and utilize in completion of the Work such materials, appliances, plants and other property belonging to the Contractor that are on the site and reasonably necessary for such completion (A special lien to secure the claims of the District in the event of such suspension is hereby created against any property of Contractor taken into the possession of the District under the terms hereof and such lien may be enforced by sale of such property under the direction of the District Board without notice to Contractor. The proceeds of the sale after deducting all expenses thereof and connected therewith shall be credited to Contractor. If the net credits shall be in excess of the claims of the District against Contractor, the balance will be paid to Contractor or Contractor's legal representatives.); and (2) Surety shall be liable to the District for any cost or other damage to the District necessitated by the District securing an alternate performance pursuant to this Article.

B. Termination for Convenience by the District:

1. The District may terminate performance of the Work called for by the Contract Documents in whole or, from time to time, in part, if the District determines that a termination is in the District's interest.
2. The Contractor shall terminate all or any part of the Work upon delivery to the Contractor of a Notice of Termination specifying that the termination is for the

GENERAL CONDITIONS
SECTION F- LABOR AND CONSTRUCTION

convenience of the District, the extent of termination, and the Effective Date of such termination.

3. After receipt of Notice of Termination, and except as directed by the District's Representative, the Contractor shall, regardless of any delay in determining or adjusting any amounts due under this Termination for Convenience clause, immediately proceed with the following obligations:
 - a. Stop Work as specified in the Notice.
 - b. Complete any Work specified in the Notice of Termination in a least cost/shortest time manner while still maintaining the quality called for under the Contract Documents.
 - c. Leave the property upon which the Contractor was working and upon which the facility (or facilities) forming the basis of the Contract Document is situated in a safe and sanitary manner such that it does not pose any threat to the public health or safety.
 - d. Terminate all subcontracts to the extent that they relate to the portions of the Work terminated.
 - e. Place no further subcontracts or orders, except as necessary to complete the continued portion of the Contract.
 - f. Submit to the District's Representative, within ten (10) calendar days from the Effective Date of the Notice of Termination, all of the usual documentation called for by the Contract Documents to substantiate all costs incurred by the Contractor for labor, materials and equipment through the Effective Date of the Notice of Termination. Any documentation substantiating costs incurred by the Contractor solely as a result of the District's exercise of its right to terminate this Contract pursuant to this clause, which costs the contractor is authorized under the Contract documents to incur, shall: (1) be submitted to and received by the Engineer no later than 30 calendar days after the Effective Date of the Notice of Termination; (2) describe the costs incurred with particularity; and (3) be conspicuously identified as "Termination Costs occasioned by the District's Termination for Convenience."
4. Termination of the Contract shall not relieve Surety of its obligation for any just claims arising out of or relating to the Work performed.
5. In the event that the District exercises its right to terminate this Contract pursuant to this clause, the District shall pay the Contractor, upon the Contractor's submission of the documentation required by this clause and other applicable provisions of the Contract Documents, the following amounts:
 - a. All actual reimbursable costs incurred according to the provisions of this Contract.

GENERAL CONDITIONS
SECTION F- LABOR AND CONSTRUCTION

- b. A reasonable allowance for profit on the cost of the Work performed, provided Contractor establishes to the satisfaction of the District's Representative that it is reasonably probable that Contractor would have made a profit had the Contract been completed and provided further, that the profit allowed shall in no event exceed fifteen (15%) percent of the costs.
 - c. A reasonable allowance for Contractor's administrative costs in determining the amount payable due to termination of the Contract under this Article.
6. Notwithstanding any other provision of this Article, when immediate action is necessary to protect life and safety or to reduce significant exposure or liability, the District may immediately order Contractor to cease Work on the Project until such safety or liability issues are addressed to the satisfaction of the District or the Contract is terminated.

ARTICLE 50 WARRANTY AND GUARANTEE OF WORK

- A. Contractor hereby warrants that materials and Work shall be completed in conformance with the Contract Documents and that the materials and Work provided will fulfill the requirements of this Warranty. Contractor hereby agrees to repair or replace, at the discretion of the District, any or all Work that may prove to be defective in its workmanship, materials furnished, methods of installation or fail to conform to the Contract Document requirements together with any other Work which may be damaged or displaced by such defect(s) within a period of one (1) year from the date of the Notice of Completion of the Project without any expense whatever to the District, ordinary wear and tear and unusual abuse and neglect excepted. Contractor shall be required to promptly repair or replace defective equipment or materials, at Contractor's option. All costs associated with such corrective actions and testing, including the removal, replacement, and reinstatement of equipment and materials necessary to gain access, shall be the sole responsibility of the Contractor.
- B. For any Work so corrected, Contractor's obligation hereunder to correct defective Work shall be reinstated for an additional one (1) year period, commencing with the date of acceptance of such corrected Work. The reinstatement of the one (1) year warranty shall apply only to that portion of work that was corrected. Contractor shall perform such tests as District may require to verify that any corrective actions, including, without limitation, redesign, repairs, and replacements comply with the requirements of the Contract. In the event of Contractor's failure to comply with the above-mentioned conditions within ten (10) calendar days after being notified in writing of required repairs, to the reasonable satisfaction of the District, the District shall have the right to correct and replace any defective or non-conforming Work and any work damaged by such work or the replacement or correction thereof at Contractor's sole expense. Contractor shall be obligated to fully reimburse the District for any expenses incurred hereunder immediately upon demand.

GENERAL CONDITIONS
SECTION F- LABOR AND CONSTRUCTION

- C. In addition to the warranty set forth in this Article, Contractor shall obtain for District all warranties that would be given in normal commercial practice and assign to District any and all manufacturer's or installer's warranties for equipment or materials not manufactured by Contractor and provided as part of the Work, to the extent that such third-party warranties are assignable and extend beyond the warranty period set forth in this Article. Contractor shall furnish the District with all warranty and guarantee documents prior to final Acceptance of the Project by the District as required.
- D. When specifically indicated in the Contract Documents or when directed by the Engineer, the District may furnish materials or products to the Contractor for installation. In the event any act or failure to act by Contractor shall cause a warranty applicable to any materials or products purchased by the District for installation by the Contractor to be voided or reduced, Contractor shall indemnify District from and against any cost, expense, or other liability arising therefrom, and shall be responsible to the District for the cost of any repairs, replacement or other costs that would have been covered by the warranty but for such act or failure to act by Contractor.
- E. The Contractor shall remedy at its expense any damage to District-owned or controlled real or personal property.
- F. The District shall notify the Contractor, in writing, within a reasonable time after the discovery of any failure, defect, or damage. The Contractor shall within ten (10) calendar days after being notified commence and perform with due diligence all necessary Work. If the Contractor fails to promptly remedy any defect, or damage; the District shall have the right to replace, repair or otherwise remedy the defect, or damage at the Contractor's expense.
- G. In the event of any emergency constituting an immediate hazard to health, safety, property, or licensees, when caused by Work of the Contractor not in accordance with the Contract requirements, the District may undertake at Contractor's expense, and without prior notice, all Work necessary to correct such condition.
- H. Acceptance of Defective Work.
 - 1. If, instead of requiring correction or removal and replacement of Defective Work, the District prefers to accept it, District may do so. Contractor shall pay all claims, costs, losses, and damages (including but not limited to all fees and charges of engineers, architects, attorneys, and other professionals and all court or arbitration or other dispute resolution costs) attributable to District's evaluation of and determination to accept such Defective Work and for the diminished value of the Work.
 - 2. If any acceptance of defective work occurs prior to release of the Project Retention, a Change Order will be issued incorporating the necessary revisions in the Contract Documents with respect to the Work, and District shall be entitled to an appropriate decrease in the Contract Price, reflecting the diminished value of Work and all costs incurred by District.

GENERAL CONDITIONS
SECTION F- LABOR AND CONSTRUCTION

3. If the Project Retention is held in an escrow account as permitted by the Contract Documents, Contractor will promptly alert the escrow holder, in writing, of the amount of Retention to be paid to District.
 4. If the acceptance of Defective Work occurs after release of the Project Retention, an appropriate amount will be paid by Contractor to District.
- I. District May Correct Defective Work.
1. If Contractor fails within a reasonable time after written notice from District's Representative to correct Defective Work, or to remove and replace rejected Work as required by District, or if Contractor fails to perform the Work in accordance with the Contract Documents, or if Contractor fails to comply with any other provision of the Contract Documents, District may, after seven (7) Days' written notice to Contractor, correct, or remedy any such deficiency.
 2. In connection with such corrective or remedial action, District may exclude Contractor from all or part of the Site, take possession of all or part of the Work and suspend Contractor's services related thereto, take possession of Contractor's tools, appliances, construction equipment and machinery at the Site, and incorporate in the Work all materials and equipment stored at the Site or for which District has paid Contractor but which are stored elsewhere. Contractor shall allow District and District's Representative, and the agents, employees, other contractors, and consultants of each of them, access to the Site to enable District to exercise the rights and remedies to correct the Defective Work.
 3. All claims, costs, losses, and damages (including but not limited to all fees and charges of engineers, architects, attorneys, and other professionals and all court or arbitration or other dispute resolution costs) incurred or sustained by District correcting the Defective Work will be charged against Contractor, and a Change Order will be issued incorporating the necessary revisions into the Contract Documents with respect to the Work; and District shall be entitled to an appropriate decrease in the Contract Price.
 4. Such claims, costs, losses and damages will include, but not be limited to, all costs of repair, or replacement of work of others destroyed or damaged by correction, removal, or replacement of Defective Work.
 5. If the Change Order is executed after all payments under the Contract have been paid by District and the Project Retention is held in an escrow account as permitted by the Contract Documents, Contractor will promptly alert the escrow holder, in writing, of the amount of Retention to be paid to District.
 6. If the Change Order is executed after release of the Project Retention, an appropriate amount will be paid by Contractor to District.
 7. Contractor shall not be allowed an extension of the Contract Times because of any delay in the performance of the Work attributable to District correcting Defective work.

GENERAL CONDITIONS
SECTION F- LABOR AND CONSTRUCTION

- J. Nothing in the Warranty or in the Contract Documents shall be construed to limit the rights and remedies available to District at law or in equity, including, but not limited to, Code of Civil Procedure section 337.15.

ARTICLE 51 DOCUMENT RETENTION & EXAMINATION

- A. In accordance with Government Code section 8546.7, records of both the District and the Contractor shall be subject to examination and audit by the State Auditor General for a period of three (3) years after final payment.
- B. Contractor shall make available to the District any of the Contractor's other documents related to the Project immediately upon request of the District.
- C. In addition to the State Auditor rights above, the District shall have the right to examine and audit all books, estimates, records, contracts, documents, bid documents, subcontracts, and other data of the Contractor (including computations and projections) related to negotiating, pricing, or performing the modification in order to evaluate the accuracy and completeness of the cost or pricing data at no additional cost to the District, for a period of four (4) years after final payment.

ARTICLE 52 SEPARATE CONTRACTS

- A. The District reserves the right to let other contracts in connection with this Work or on the Project site. Contractor shall permit other contractors reasonable access and storage of their materials and execution of their work and shall properly connect and coordinate its Work with theirs.
- B. To ensure proper execution of its subsequent Work, Contractor shall immediately inspect work already in place and shall at once report to the Engineer any problems with the Work in place or discrepancies with the Contract Documents.
- C. Contractor shall ascertain to its own satisfaction the scope of the Project and nature of any other contracts that have been or may be awarded by the District in prosecution of the Project to the end that Contractor may perform this Contract in the light of such other contracts, if any. Nothing herein contained shall be interpreted as granting to Contractor exclusive occupancy at site of the Project. Contractor shall not cause any unnecessary hindrance or delay to any other contractor working on the Project. If simultaneous execution of any contract for the Project is likely to cause interference with performance of some other contract or contracts, the Engineer shall decide which Contractor shall cease Work temporarily and which contractor shall continue or whether work can be coordinated so that contractors may proceed simultaneously. The District shall not be responsible for any damages suffered or for extra costs incurred by Contractor resulting directly or indirectly from award, performance, or attempted performance of any other contract or contracts on the Project site.

**GENERAL CONDITIONS
SECTION F- LABOR AND CONSTRUCTION**

ARTICLE 53 NOTICE AND SERVICE THEREOF

All notices shall be in writing and either served by personal delivery or mailed to the other party as designated in the Bid Forms. Written notice to the Contractor shall be addressed to Contractor's principal place of business unless Contractor designates another address in writing for service of notice. Notice to District shall be addressed to the District as designated in the Notice Inviting Bids unless District designates another address in writing for service of notice. Notice shall be effective upon receipt or five (5) calendar days after being sent by first class mail, whichever is earlier. Notice given by facsimile shall not be effective unless acknowledged in writing by the receiving party.

ARTICLE 54 NOTICE OF THIRD PARTY CLAIMS

Pursuant to Public Contract Code section 9201, the District shall provide the Contractor with timely notification of the receipt of any third-party claims relating to the Contract. The District is entitled to recover reasonable costs incurred in providing such notification.

ARTICLE 55 STATE LICENSE BOARD NOTICE

Contractors are required by law to be licensed and regulated by the Contractors' State License Board which has jurisdiction to investigate complaints against contractors if a complaint regarding a patent act or omission is filed within four (4) years of the date of the alleged violation. A complaint regarding a latent act or omission pertaining to structural defects must be filed within ten (10) years of the date of the alleged violation. Any questions concerning a contractor may be referred to the Registrar, Contractors' State License Board, P.O. Box 26000, Sacramento, California 95826.

ARTICLE 56 INTEGRATION

- A. **Oral Modifications Ineffective.** No oral order, objection, direction, claim or notice by any party or person shall affect or modify any of the terms or obligations contained in the Contract Documents.
- B. **Contract Documents Represent Entire Contract.** The Contract Documents represent the entire agreement of the District and Contractor.

ARTICLE 57 ASSIGNMENT OF CONTRACT

Contractor shall not assign, transfer, convey, sublet or otherwise dispose of the rights or title of interest of any or all of this contract without the prior written consent of the District. Any assignment or change of Contractor's name of legal entity without the written consent of the District shall be void. Any assignment of money due or to become due under this Contract shall be subject to a prior lien for services rendered or Material supplied for performance of Work called for under the Contract Documents in favor of all persons, firms, or corporations rendering such services or supplying such Materials to the extent that claims are filed pursuant to the Civil Code, the Code of Civil Procedure or the Government Code.

GENERAL CONDITIONS
SECTION F- LABOR AND CONSTRUCTION

ARTICLE 58 CHANGE IN NAME AND NATURE OF CONTRACTOR'S LEGAL ENTITY

Should a change be contemplated in the name or nature of the Contractor's legal entity, the Contractor shall first notify the District in order that proper steps may be taken to have the change reflected on the Contract and all related documents. No change of Contractor's name or nature will affect District's rights under the Contract, including but not limited to the bonds.

ARTICLE 59 ASSIGNMENT OF ANTITRUST ACTIONS

Pursuant to Public Contract Code section 7103.5, in entering into a public works contract or subcontract to supply goods, services, or materials pursuant to a public works contract, Contractor or subcontractor offers and agrees to assign to the District all rights, title, and interest in and to all causes of action it may have under Section 4 of the Clayton Act (15 USC, Section 15) or under the Cartwright Act (Chapter 2 (commencing with Section 16700) of Part 2 of Division 7 of the Business and Professions Code), arising from the purchase of goods, services, or materials pursuant to this contract or any subcontract. This assignment shall be made and become effective at the time the District tenders final payment to the Contractor, without further acknowledgment by the parties.

ARTICLE 60 PROHIBITED INTERESTS

No District official or representative who is authorized in such capacity and on behalf of the District to negotiate, supervise, make, accept, or approve, or to take part in negotiating, supervising, making, accepting or approving any engineering, inspection, construction or material supply contract or any subcontract in connection with construction of the project, shall ARTICLE 11 be or become directly or indirectly interested financially in the Contract.

ARTICLE 61 CONTROLLING LAW

Notwithstanding any subcontract or other contract with any subcontractor, supplier, or other person or organization performing any part of the Work, this Contract shall be governed by the law of the State of California excluding any choice of law provisions.

ARTICLE 62 JURISDICTION; VENUE

Contractor and any subcontractor, supplier, or other person or organization performing any part of the Work agrees that any action or suits at law or in equity arising out of or related to the bidding, award, or performance of the Work shall be maintained in the Superior Court of Riverside County, California, and expressly consent to the jurisdiction of said court, regardless of residence or domicile, and agree that said court shall be a proper venue for any such action.

ARTICLE 63 LAWS AND REGULATIONS

- A. Contractor shall give all notices and comply with all laws, ordinances, rules and regulations bearing on conduct of work as indicated and specified. If Contractor observes that drawings and specifications are at variance therewith, it shall promptly notify the Engineer in writing and any necessary changes shall be adjusted as provided for in this Contract for changes in work. If Contractor performs any work knowing it to be contrary to such laws, ordinances, rules and

GENERAL CONDITIONS
SECTION F- LABOR AND CONSTRUCTION

regulations, and without such notice to the Engineer, it shall bear all costs arising therefrom.

- B. Contractor shall be responsible for familiarity with the Americans with Disabilities Act ("ADA") (42 U.S.C. § 12101 et seq.). The Work will be performed in ARTICLE 11 compliance with ADA regulations.

ARTICLE 64 PATENTS

Contractor shall hold and save the District, officials, officers, employees, and authorized volunteers harmless from liability of any nature or kind of claim therefrom including costs and expenses for or on account of any patented or unpatented invention, article or appliance manufactured, furnished or used by Contractor in the performance of this contract.

ARTICLE 65 OWNERSHIP OF CONTRACT DOCUMENTS

All Contract Documents furnished by the District are District property. They are not to be used by Contractor or any subcontractor on other work nor shall Contractor claim any right to such documents. With exception of one complete set of Contract Documents, all documents shall be returned to the District on request at completion of the Work.

ARTICLE 66 NOTICE OF TAXABLE POSSESSORY INTEREST

In accordance with Revenue and Taxation Code section 107.6, the Contract Documents may create a possessory interest subject to personal property taxation for which Contractor will be ARTICLE 11 responsible.

ARTICLE 67 SURVIVAL OF OBLIGATIONS

All representations, indemnifications, warranties, and guarantees made in, required by, or given in accordance with the Contract Documents, as well as all continuing obligations indicated in the Contract Documents, will survive final payment, completion, and acceptance of the Work or termination or completion of the Contract or termination of the services of Contractor.

**EXHIBIT "A"
CHANGE ORDER FORM**

Valley-Wide Recreation and Park District

*901 W. Esplanade Avenue
San Jacinto, California*

Contract Change Order #

Project:	Change Order No.:		
	Orig. Contract Amt.: \$		Days
Contract No.:			
Contractor:	Prev. Appvd. Changes: \$		Days
Owner: Valley-Wide Recreation and Park District	This Change: \$		Days
	Revised Contract Amt.: \$		Days

This Change Order covers changes to the subject contract as described herein. The Contractor shall construct, furnish equipment and materials, and perform all work as necessary or required to complete the Change Order items for a lump sum price agreed upon between the Contractor and Valley-Wide Recreation and Park District, otherwise referred to as Owner.

Item No.	Description of Changes	Increase/ (Decrease) in Contract Amount	Contract Time Extension, Days
1			
2			
	Totals	\$	

This Contract Change Order consists of **2 pages** and any exhibits attached to this Contract Change Order shall not be part of the Contract Change Order unless specifically initiated by or on behalf of both the Contractor and the Valley-Wide Recreation and Park District.

Contract Change Order # _____ Page 1 of 2

The amount of the contract will be increased by the sum of \$_____ and the contract time shall be extended by working days. The undersigned Contractor approves the foregoing Change Order # as to the changes, if any, in the contract price specified for each item including any and all supervision costs and other miscellaneous costs relating to the change in work, and as to the extension of time allowed, if any, for completion of the entire work on account of said Change Order #. The Contractor agrees to furnish all labor and materials and perform all other necessary work, inclusive of the directly or indirectly related to the approved time extension, required to complete the Change order items. This document will become a supplement of the contract and all provisions will apply hereto. It is understood that the Change Order shall be effective when approved by the Owner.

Contractor accepts the terms and conditions stated above as full and final settlement of any and all claims arising out of or related to the subject of this Change Order and acknowledges that the compensation (time and cost) set forth herein comprises the total compensation due for the work or change defined in the Change Order, including all impact on any unchanged work. By signing this Change Order, the Contractor acknowledges and agrees that the stipulated compensation includes payment for all Work contained in the Change Order, plus all payment for any acceleration or interruption of schedules, extended overhead costs, delay, and all impact or cumulative impact on all Work under this Contract. The signing of this Change Order acknowledges full mutual accord and satisfaction for the change and that the stated time and/or cost constitute the total equitable adjustment owed the Contractor as a result of the change. The Contractor hereby releases and agrees to waive all rights, without exception or reservation of any kind whatsoever, to file any further claim or request for equitable adjustment of any type, for any reasonably foreseeable cause that shall arise out of, or as a result of, this Change Order and/or its impact on the remainder of the Work under the Contract.

Accepted:

 (Signature) Contractor's Authorized Representative

 Date

Recommended:

 (Signature) ****INSERT NAME, TITLE****

 Date

Approved:

 (Signature) ****INSERT NAME, TITLE****

 Date

Item No.	Justification for Change(s)
1	
2	

This Contract Change Order consists of **2 pages** and any exhibits attached to this Contract Change Order shall not be part of the Contract Change Order unless specifically initiated by or on behalf of both the Contractor and the Valley-Wide Recreation and Park District.

Contract Change Order #

Page 2 of 2

VALLEY-WIDE RECREATION
DIAMOND VALLEY LAKE COMMUNITY PARK
DEDICATION WALL AND PICKLEBALL COURT IMPROVEMENTS
SECTION SC-SPECIAL CONDITIONS

SC-01. SCOPE OR WORK

New Pickleball Court expansion, to include grading, concrete removal, new concrete, court surfacing, site amenities, fencing and landscape and irrigation modifications.

SC-02. PRECONSTRUCTION AND CONSTRUCTION COMMUNICATION

Before any Work at the site is started, a conference attended by the District, Contractor, District's Representative, and others as appropriate will be held to establish a working understanding among the parties as to the Work and to discuss the schedules referred to herein, procedures for handling Shop Drawings and other submittals, processing Applications for Payment, and maintaining required records.

At this conference the District and Contractor each shall designate, in writing, a specific individual to act as its authorized representative with respect to the services and responsibilities under the Contract. Such individuals shall have the authority to transmit instructions, receive information, render decisions relative to the Contract, and otherwise act on behalf of each respective party.

SC-03. CONTRACT DOCUMENTS: COPIES & MAINTENANCE

Contractor will be furnished, free of charge, **five (5)** copies of the Contract Documents. Additional copies may be obtained at cost of reproduction.

Contractor shall maintain a clean, undamaged set of Contract Documents, including submittals, at the Project site.

SC-04. EXAMINATION OF DRAWINGS, SPECIFICATIONS AND SITE OF WORK

- A. **Examination of Contract Documents.** Before commencing any portion of the Work, Contractor shall again carefully examine all applicable Contract Documents, the Project site, and other information given to Contractor as to materials and methods of construction and other Project requirements. Contractor shall immediately notify the Engineer of any potential error, Inconsistency, ambiguity, conflict, or lack of detail or explanation. If Contractor performs, permits, or causes the performance of any Work which is in error, inconsistent or ambiguous, or not sufficiently detailed or explained, Contractor shall bear any and all resulting costs, including, without limitation, the cost of correction. In no case shall the Contractor or any subcontractor proceed with Work if uncertain as to the applicable requirements.
- B. **Additional Instructions.** After notification of any error, inconsistency, ambiguity, conflict, or lack of detail or explanation, the Engineer will provide any required additional instructions, by means of drawings or other written direction, necessary for proper execution of Work.
- C. **Quality of Parts, Construction and Finish.** All parts of the Work shall be of the best quality of their respective kinds and the Contractor must use all diligence to inform itself fully as to the required construction and finish.

VALLEY-WIDE RECREATION
DIAMOND VALLEY LAKE COMMUNITY PARK
DEDICATION WALL AND PICKLEBALL COURT IMPROVEMENTS

SECTION SC-SPECIAL CONDITIONS

- D. **Contractor's Variation from Contract Document Requirements.** If it is found that the Contractor has varied from the requirements of the Contract Documents including the requirement to comply with all applicable laws, ordinances, rules and regulations, the Engineer may at any time, before or after completion of the Work, order the improper Work removed, remade or replaced by the Contractor at the Contractor's expense.

SC-05

MOBILIZATION

- A. When a bid item is included in the Bid Form for mobilization, the costs of Work in advance of construction operations and not directly attributable to any specific bid item will be included in the progress estimate ("Initial Mobilization"). When no bid item is provided for "Initial Mobilization," payment for such costs will be deemed to be included in the other items of the Work.
- B. Payment for Initial Mobilization based on the lump sum provided in the Bid Form, which shall constitute full compensation for all such Work. No payment for Initial Mobilization will be made until all of the listed items have been completed to the satisfaction of the Engineer. The scope of the Work included under Initial Mobilization shall include, but shall not be limited to, the following principal items:
1. Obtaining and paying for all bonds, insurance, and permits.
 2. Moving on to the Project site of all Contractor's plant and equipment required for the first month's operations.
 3. Installing temporary construction power, wiring, and lighting facilities, as applicable.
 4. Establishing fire protection system, as applicable.
 5. Developing and installing a construction water supply, if applicable.
 6. Providing and maintaining the field office trailers for the Contractor, if necessary, and the Engineer (if specified), complete, with all specified furnishings and utility services.
 7. Providing on-site sanitary facilities and potable water facilities as specified per Cal-OSHA and these Contract Documents.
 8. Furnishing, installing, and maintaining all storage buildings or sheds required for temporary storage of products, equipment, or materials that have not yet been installed in the Work. All such storage shall meet manufacturer's specified storage requirements, and the specific

VALLEY-WIDE RECREATION
DIAMOND VALLEY LAKE COMMUNITY PARK
DEDICATION WALL AND PICKLEBALL COURT IMPROVEMENTS

SECTION SC-SPECIAL CONDITIONS

provisions of the specifications, including temperature and humidity control, if recommended by the manufacturer, and for all security.

9. Arranging for and erection of Contractor's work and storage yard.\
10. Posting all OSHA required notices and establishment of safety programs per Cal-OSHA.
11. Full-time presence of Contractor's superintendent at the job site as required herein.
12. Submittal of Construction Schedule as required by the Contract Documents.

SC-06. EXISTENCE OF UTILITIES AT THE WORK SITE

1. The District has endeavored to determine the existence of utilities at the Project site from the records of the owners of known utilities in the vicinity of the Project. The positions of these utilities as derived from such records are shown on the Plans.
2. Unless indicated otherwise on the Plans and Specifications, no excavations were made to verify the locations shown for underground utilities. The service connections to these utilities are not shown on the Plans. Water service connections may be shown on the Plans showing general locations of such connections. It shall be the responsibility of the Contractor to determine the exact location of all service connections. The Contractor shall make its own investigations, including exploratory excavations, to determine the locations and type of service connections, prior to commencing Work which could result in damage to such utilities. The Contractor shall immediately notify the District in writing of any utility discovered in a different position than shown on the Plans or which is not shown on the Plans.
3. If applicable, all water meters, water valves, fire hydrants, electrical utility vaults, telephone vaults, gas utility valves, and other subsurface structures shall be relocated or adjusted to final grade by the Contractor. Locations of existing utilities shown on the Plans are approximate and may not be complete. The Contractor shall be responsible for coordinating its Work with all utility companies during the construction of the Work.
4. Notwithstanding the above, pursuant to section 4215 of the Government Code, the District has the responsibility to identify, with reasonable accuracy, main or trunkline facilities on the plans and specifications. In the event that main or trunkline utility facilities are not identified with reasonable accuracy in the plans and specifications made a part of the

VALLEY-WIDE RECREATION
DIAMOND VALLEY LAKE COMMUNITY PARK
DEDICATION WALL AND PICKLEBALL COURT IMPROVEMENTS

SECTION SC-SPECIAL CONDITIONS

invitation for Bids, the District shall assume the responsibility for their timely removal, relocation, or protection.

5. Contractor, except in an emergency, shall contact the appropriate regional notification center, **Southern California Underground Service**

Alert at 811 or 1-800-227-2600 or on-line at www.digalert.org at least two working days prior to commencing any excavation if the excavation will be performed in an area which is known, or reasonably should be known, to contain subsurface installations other than the underground facilities owned or operated by the District, and obtain an inquiry identification number from that notification center. No excavation shall be commenced or carried out by the Contractor unless such an inquiry identification number has been assigned to the Contractor or any subcontractor of the Contractor and the District has been given the identification number by the Contractor.

SC-07 SOILS INVESTIGATIONS

- A. **Reports and Drawings.** The Special Conditions identify:

1. Those reports known to the District of explorations and tests of subsurface conditions at or contiguous to the site; and
2. Those drawings known to the District of physical conditions relating to existing surface or subsurface structures at the site (except Underground Facilities).
3. **Limited Reliance by Contractor on Technical Data Authorized.** Contractor may rely upon the accuracy of the “technical data” contained in such reports and drawings, which were expressly not created or obtained to evaluate or assist in the evaluation of constructability, and are not Contract Documents. Contractor shall make its own interpretation of the “technical data” and shall be solely responsible for any such interpretations. Except for reliance on the accuracy of such “technical data,” Contractor may not rely upon or make any claim against the District, District’s Representative, or Engineer of Record, or any of their officers, directors, members, partners, employees, agents, consultants, or subcontractors, with respect to:
4. The completeness of such reports and drawings for Contractor’s purposes, including without limitation any aspects of the means, methods, techniques, sequences, and procedures of construction to be employed by Contractor, and safety precautions and programs incident thereto; or
5. Other data, interpretations, opinions, conclusions and information contained in such reports or shown or indicated in such drawings; or

VALLEY-WIDE RECREATION
DIAMOND VALLEY LAKE COMMUNITY PARK
DEDICATION WALL AND PICKLEBALL COURT IMPROVEMENTS
SECTION SC-SPECIAL CONDITIONS

6. Any Contractor interpretation of or conclusion drawn from any “technical data” or any such other data, interpretations, opinions, or information.

SC-08 CONTRACTOR’S SUPERVISION

Contractor shall continuously keep at the Project site, a competent and experienced full-time Project superintendent acceptable to the District. Superintendent must be able to proficiently speak, read and write in English and shall have the authority to make decisions on behalf of the Contractor. Contractor shall continuously provide efficient supervision of the Project.

SC-09. WORKERS

Contractor shall at all times enforce strict discipline and good order among its employees. Contractor shall not employ on the Project any unfit person or any one not skilled in the Work assigned to him or her.

Any person in the employ of the Contractor whom the District may deem incompetent or unfit shall be dismissed from the Work and shall not be employed on this Project.

SC-10. INDEPENDENT CONTRACTORS

Contractor shall be an independent contractor for the District and not an employee. Contractor understands and agrees that it and all of its employees shall not be considered officers, employees, or agents of District and are not entitled to benefits of any kind normally provided employees of District, including but not limited to, state unemployment compensation or workers’ compensation. Contractor assumes full responsibility for the acts and omissions of its employees or agents related to the Work.

SC-11. SUBCONTRACTS

1. Contractor agrees to bind every subcontractor to the terms of the Contract Documents as far as such terms are applicable to subcontractor’s portion of the Work. Contractor shall be as fully responsible to the District for the acts and omissions of its subcontractors and of persons either directly or indirectly employed by its subcontractors, as Contractor is for acts and omissions of persons directly employed by Contractor. Nothing contained in these Contract Documents shall create any contractual relationship between any subcontractor and the District.
2. The District reserves the right to accept all subcontractors. The District’s acceptance of any subcontractor under this Contract shall not in any way relieve Contractor of its obligations in the Contract Documents.
3. Prior to substituting any subcontractor listed in the Bid Forms, Contractor must comply with the requirements of the Subletting and Subcontracting Fair Practices Act pursuant to California Public Contract Code section 4100 et seq.

SC-12. VERIFICATION OF EMPLOYMENT ELIGIBILITY

By executing this Contract, Contractor verifies that it fully complies with all requirements and restrictions of state and federal law respecting the employment of undocumented aliens, including, but not limited to, the Immigration Reform and Control Act of 1986, as may be amended from time

VALLEY-WIDE RECREATION
DIAMOND VALLEY LAKE COMMUNITY PARK
DEDICATION WALL AND PICKLEBALL COURT IMPROVEMENTS

SECTION SC-SPECIAL CONDITIONS

to time, and shall require all subcontractors, sub-subcontractors and consultants to comply with the same. Each person executing this Contract on behalf of Contractor verifies that he or she is a duly authorized officer of Contractor and that any of the following shall be grounds for the District to terminate the Contract for cause: (1) failure of the Contractor or its subcontractors, sub-subcontractors or consultants to meet any of the requirements provided for in this Article; (2) any misrepresentation or material omission concerning compliance with such requirements; or (3) failure to immediately remove from the Work any person found not to be in compliance with such requirements.

SC-13. REQUESTS FOR SUBSTITUTION

For the purposes of this provision, the term “substitution” shall mean the substitution of any material, method or service substantially equal to or better in every respect to that indicated in the Standard Specifications or otherwise referenced herein.

- A. Pursuant to Public Contract Code section 3400(b), the District may make a finding that is described in the Notice Inviting Bids that designates certain products, things, or services by specific brand or trade name.
- B. Unless specifically designated in the Special Conditions, whenever any material, process, or article is indicated or specified by grade, patent, or proprietary name or by name of manufacturer, such specifications shall be deemed to be used for the purpose of facilitating the description of the material, process, or article desired and shall be deemed to be followed by the words “or equal.” Contractor may, unless otherwise stated, offer for substitution any material, process, or article which may be substantially equal to or better in every respect to that so indicated or specified in the Contract Documents. However, the District has adopted uniform standards for certain materials, processes, and articles.
- C. The Contractor shall submit substitution requests, together with substantiating data, for substitution of any “or equal” material, process, or article no later than thirty-five (35) calendar days after award of Contract. Provisions regarding submission of substitution requests shall not in any way authorize an extension of time for the performance of this Contract. If a substitution request is rejected by the District, the Contractor shall provide the material, method or service specified herein. The District shall not be responsible for any costs incurred by the Contractor associated with substitution requests. The burden of proof as to the equality of any material, process, or article shall rest with the Contractor. The Engineer has the complete and sole discretion to determine if a material, process, or article is substantially equal to or better than that specified and to approve or reject all substitution requests.
- D. Substantiating data as described above shall include, at a minimum, the following information:

VALLEY-WIDE RECREATION
DIAMOND VALLEY LAKE COMMUNITY PARK
DEDICATION WALL AND PICKLEBALL COURT IMPROVEMENTS

SECTION SC-SPECIAL CONDITIONS

1. A signed affidavit from the Contractor stating that the material, process, or article proposed as a substitution is substantially equal to or better than that specified in every way except as may be listed on the affidavit.
 2. Illustrations, specifications, catalog cut sheets, and any other relevant data required to prove that the material, process, or article is substantially equal to or better than that specified.
 3. A statement of the cost implications of the substitution being requested, indicating whether and why the proposed substitution will reduce or increase the amount of the contract.
 4. Information detailing the durability and lifecycle costs of the proposed substitution.
- E. Failure to submit all the required substantiating data detailed above in a timely manner so that the substitution request can be adequately reviewed may result in rejection of the substitution request. The Engineer is not obligated to review multiple submittals related the same substitution request resulting from the Contractor's failure to initially submit a complete package.
- F. Time limitations within this Article shall be strictly complied with and in no case will an extension of time for completion of the contract be granted because of Contractor's failure to provide substitution requests at the time and in the manner described herein.\
- G. The Contractor shall bear the costs of all District work associated with the review of substitution requests.
- H. If substitution requests approved by the Engineer require that Contractor furnish materials, methods or services more expensive than that specified, the increased costs shall be borne by Contractor.

SC-14.

SHOP DRAWINGS

- A.** Contractor shall check and verify all field measurements and shall submit with such promptness as to provide adequate time for review and cause no delay in its own Work or in that of any other contractor, subcontractor, or worker on the Project, six (6) copies of all shop drawings, calculations, schedules, and materials list, and all other provisions required by the Contract Documents. Contractor shall sign all submittals affirming that submittals have been reviewed and approved by Contractor prior to submission to Engineer. Each signed submittal shall affirm that the submittal meets all the requirements of the Contract Documents except

VALLEY-WIDE RECREATION
DIAMOND VALLEY LAKE COMMUNITY PARK
DEDICATION WALL AND PICKLEBALL COURT IMPROVEMENTS

SECTION SC-SPECIAL CONDITIONS

as specifically and clearly noted and listed on the transmittal letter of the submittal.

- B. Contractor shall make any corrections required by the Engineer, and file with the Engineer six (6) corrected copies each, and furnish such other copies as may be needed for completion of the Work. Engineer's acceptance of shop drawings shall not relieve Contractor from responsibility for deviations from the Contract Documents unless Contractor has, in writing, called Engineer's attention to such deviations at time of submission and has secured the Engineer's written acceptance. Engineer's acceptance of shop drawings shall not relieve Contractor from responsibility for errors in shop drawings.

SC-15. SUBMITTALS

- A. Contractor shall furnish to the Engineer for approval, prior to purchasing or commencing any Work, a log of all samples, material lists and certifications, mix designs, schedules, and other submittals, as required in the Contract Documents. The log shall indicate whether samples will be provided in accordance with other provisions of this Contract.
- B. Contractor will provide samples and submittals, together with catalogs and supporting data required by the Engineer, to the Engineer within a reasonable time period to provide for adequate review and avoid delays in the Work.
- C. These requirements shall not authorize any extension of time for performance of this Contract. Engineer will check and approve such samples, but only for conformance with design concept of work and for compliance with information given in the Contract Documents. Work shall be in accordance with approved samples and submittals.

SC-16. MATERIALS

- A. Except as otherwise specifically stated in the Contract Documents, Contractor shall provide and pay for all materials, labor, tools, equipment, lights, power, transportation, superintendence, temporary constructions of every nature, and all other services and facilities of every nature whatsoever necessary to execute and complete this Contract within specified time.
- B. Unless otherwise specified, all materials shall be new and the best of their respective kinds and grades as noted and/or specified, and workmanship shall be of good quality.
- C. Materials shall be furnished in ample quantities and at such times as to ensure uninterrupted progress of the Work and shall be stored properly and protected as required by the Contract Documents. Contractor shall

VALLEY-WIDE RECREATION
DIAMOND VALLEY LAKE COMMUNITY PARK
DEDICATION WALL AND PICKLEBALL COURT IMPROVEMENTS
SECTION SC-SPECIAL CONDITIONS

be entirely responsible for damage or loss by weather or other causes to materials or Work.

- D. No materials, supplies, or equipment for Work under this Contract shall be purchased subject to any chattel mortgage or under a conditional sale or other agreement by which an interest therein or in any part thereof is retained by the seller or supplier. Contractor warrants good title to all material, supplies, and equipment installed or incorporated in the Work and agrees upon completion of all work to deliver the Project, to the District free from any claims, liens, or charges.
- E. Materials shall be stored on the Project site in such manner so as not to interfere with any operations of the District or any independent contractor.
- F. Contractor shall verify all measurements, dimensions, elevations, and quantities before ordering any materials or performing any Work, and the District shall not be liable for Contractor's failure to do so. No additional compensation, over and above payment for the actual quantities at the prices set out in the Bid Form, will be allowed because of differences between actual measurements, dimension, elevations and quantities and those indicated on the Plans and in the Specifications. Any difference therein shall be submitted to the Engineer for consideration before proceeding with the Work.

SC-17. PERMITS AND LICENSES

- A. District will apply and pay for the review of necessary encroachment permits for Work within the public rights-of-way. Contractor shall obtain all other necessary permits and licenses for the construction of the Project, including encroachment permits, and shall pay all fees required by law and shall comply with all laws, ordinances, rules and regulations relating to the Work and to the preservation of public health and safety. Before acceptance of the Project, the Contractor shall submit all licenses, permits, certificates of inspection and required approvals to the District.
- B. The Bid Form contains an allowance for the Contractor's cost of acquiring traffic control permits and for construction inspection fees that may be charged to the Contractor by the Agency of Jurisdiction. The allowance is included within the Bid Form to eliminate the need by bidders to research or estimate the costs of traffic control permits and construction inspection fees prior to submitting a bid. The allowance is specifically intended to account for the costs of traffic control permits and construction inspection fees charged by the local Agency of Jurisdiction only. No other costs payable by Contractor to the Agency of Jurisdiction are included within the allowance. Payment by District to Contractor under the Permit and Inspection Allowance Bid Item shall be made based on actual cost receipts only and in accordance with the provisions of these specifications.

VALLEY-WIDE RECREATION
DIAMOND VALLEY LAKE COMMUNITY PARK
DEDICATION WALL AND PICKLEBALL COURT IMPROVEMENTS
SECTION SC-SPECIAL CONDITIONS

SC-18.

TRENCHES

- A. Trenches Five Feet or More in Depth.** Contractor shall submit to the Engineer at the preconstruction meeting, a detailed plan showing the design of shoring, bracing, sloping or other provisions to be made for worker protection from hazards of caving ground during the excavation of any trench or trenches five feet or more in depth. If such plan varies from shoring system standards established by the Construction Safety Orders of the California Code of Regulations, Department of Industrial Relations, the plan shall be prepared by a California registered civil or structural engineer. The plan shall not be less effective than the shoring, bracing, sloping, or other provisions of the Construction Safety Orders, as defined in the California Code of Regulations. The Contractor shall designate in writing the “competent person” as defined in Title 8, California Code of Regulations, who shall be present at the Work Site each day that trenching/excavation is in progress. The “competent person” shall prepare and provide daily trenching/excavation inspection reports to the Engineer. Contractor shall also submit a copy of its annual California Occupational Safety and Health Administration (Cal/OSHA) trench/excavation permit.
- B. Excavations Deeper than Four Feet.** If the Work involves excavating trenches or other excavations that extend deeper than four feet below the surface, Contractor shall promptly, and before the excavation is further disturbed, notify the District in writing of any of the following conditions:
- C.** Material that the Contractor believes may be material that is hazardous waste, as defined in section 25117 of the Health and Safety Code, that is required to be removed to a Class I, Class II, or Class III disposal site in accordance with provisions of existing law.
- D.** Subsurface or latent physical conditions at the site differing from those indicated.
- E.** Unknown physical conditions at the site of any unusual nature, different materially from those ordinarily encountered and generally recognized as inherent in work of the character provided for in the Contract

The District shall promptly investigate the conditions, and if it finds that the conditions do so materially differ, or do involve hazardous waste, and cause a decrease or increase in Contractor’s cost of, or the time required for, performance of any part of the Work, shall issue a change order under the procedures described in the Contract Documents.

In the event that a dispute arises between the District and the Contractor as to whether the conditions materially differ, or involve hazardous waste, or cause a decrease or increase in the Contractor’s cost of, or time required for, performance of any part of the Work, the Contractor shall not be excused from any scheduled

VALLEY-WIDE RECREATION
DIAMOND VALLEY LAKE COMMUNITY PARK
DEDICATION WALL AND PICKLEBALL COURT IMPROVEMENTS
SECTION SC-SPECIAL CONDITIONS

completion date provided for by the Contract, but shall proceed with all Work to be performed under the Contract. Contractor shall retain any and all rights provided either by contract or by law which pertain to the resolution of disputes and protests between the parties.

SC-19. TRAFFIC CONTROL

- A. Traffic control plan(s) for the Work may be required by the Agency(s) of Jurisdiction. Traffic control plans, if required, shall be prepared at Contractor's expense, and traffic control shall be performed at Contractor's expense in accordance with the requirements of the Agency(s) of Jurisdiction. The Permit and Inspection Allowance included within the Bid Form includes the cost of required traffic control permit(s) and construction inspection by the Agency(s) of Jurisdiction only. The Permit and Inspection Allowance does not include costs for preparation of any required traffic control plans, implementation of any traffic control requirements or for any traffic signal services that may be required. Costs for traffic control plans, implementation of traffic control, or traffic signal services required by the Agency(s) of Jurisdiction shall be included in the Contractor's Bid.

- B. All warning signs and safety devices used by the Contractor to perform the Work shall conform to the requirements contained in the State of California, Department of Transportation's current edition of "Manual of Traffic Controls for Construction and Maintenance Work Zones" or to the requirements of the local agency. The Contractor shall also be responsible for all traffic control required by the agency having jurisdiction over the project on the intersecting streets. Contractor must submit a traffic control plan to the agency having jurisdiction over the project for approval prior to starting work.

- C. The Contractor's representative on the site responsible for traffic control shall produce evidence that he/she has completed training acceptable to the California Department of Transportation for safety through construction zones. All of the streets in which the Work will occur shall remain open to traffic and one lane of traffic maintained at all times unless otherwise directed by the agency of jurisdiction. Businesses and residences adjacent to the Work shall be notified forty-eight (48) hours in advance of closing of driveways. The Contractor shall make every effort to minimize the amount of public parking temporarily eliminated due to construction in areas fronting businesses. No stockpiles of pipe or other material will be allowed in traveled right-of-ways after working hours unless otherwise approved by the Engineer.

SC-20. DIVERSION OF RECYCLABLE WASTE MATERIALS

In compliance with the applicable District's waste reduction and recycling efforts, Contractor shall divert all Recyclable Waste Materials to appropriate recycling centers as required for compliance with the local jurisdiction's waste diversion ordinances. Contractor will be required

VALLEY-WIDE RECREATION
DIAMOND VALLEY LAKE COMMUNITY PARK
DEDICATION WALL AND PICKLEBALL COURT IMPROVEMENTS

SECTION SC-SPECIAL CONDITIONS

to submit weight tickets and written proof of diversion with its monthly progress payment requests. Contractor shall complete and execute any certification forms required by District or other applicable agencies to document Contractor's compliance with these diversion requirements. All costs incurred for these waste diversion efforts shall be the responsibility of the Contractor.

SC-21. REMOVAL OF HAZARDOUS MATERIALS

Should Contractor encounter material reasonably believed to be polychlorinated biphenyl (PCB) or other toxic wastes and hazardous materials which have not been rendered harmless at the Project site, the Contractor shall immediately stop work at the affected Project site and shall report the condition to the District in writing. The District shall contract for any services required to directly remove and/or abate PCBs and other toxic wastes and hazardous materials, if required by the Project site(s), and shall not require the Contractor to subcontract for such services. The Work in the affected area shall not thereafter be resumed except by written agreement of the District and Contractor.

SC-22. SANITARY FACILITIES

Contractor shall provide sanitary temporary toilet buildings and hand washing facilities for the use of all workers. All toilets and hand washing facilities shall comply with local codes and ordinances. Toilets shall be kept supplied with toilet paper and shall have workable door fasteners. Toilets and hand washing facilities shall be serviced no less than once weekly and shall be present in a quantity of not less than 1 per 20 workers as required by Cal/OSHA regulations. The toilets and hand washing facilities shall be maintained in a sanitary condition at all times. Use of toilet and hand washing facilities in the Work under construction shall not be permitted. Any other Sanitary Facilities required by Cal/OSHA shall be the responsibility of the Contractor.

SC-23. AIR POLLUTION CONTROL

Contractor shall comply with all air pollution control rules, regulations, ordinances and statutes, including, but not limited to, those required by the South Coast Air Quality Management District. All containers of paint, thinner, curing compound, solvent or liquid asphalt shall be labeled to indicate that the contents fully comply with the applicable material requirements.

SC-24. LAYOUT AND FIELD ENGINEERING

All field engineering required for laying out the Work and establishing grades for earthwork operations shall be furnished by the Contractor at its expense.

SC-25. TESTS AND INSPECTIONS

- A. If the Contract Documents, the Engineer, or any instructions, laws, ordinances, or public authority requires any part of the Work to be tested or Approved, Contractor shall provide the Engineer at least two (2) working days' notice of its readiness for observation or inspection. If inspection is by a public authority other than the District, Contractor shall promptly inform the District of the date fixed for such inspection. Required certificates of inspection (or similar) shall be secured by Contractor. Costs for District testing and District inspection shall be paid

VALLEY-WIDE RECREATION
DIAMOND VALLEY LAKE COMMUNITY PARK
DEDICATION WALL AND PICKLEBALL COURT IMPROVEMENTS

SECTION SC-SPECIAL CONDITIONS

by the District. Costs of tests for Work found not to be in compliance shall be paid by the Contractor.

- B. If any Work is done or covered up without the required testing or approval, the Contractor shall uncover or deconstruct the Work, and the Work shall be redone after completion of the testing at the Contractor's cost in compliance with the Contract Documents.
- C. Where inspection and testing are to be conducted by an independent laboratory or agency, materials or samples of materials to be inspected or tested shall be selected by such laboratory or agency, or by the District, and not by Contractor. All tests or inspections of materials shall be made in accordance with the commonly recognized standards of national organizations.
- D. In advance of manufacture of materials to be supplied by Contractor which must be tested or inspected, Contractor shall notify the District so that the District may arrange for testing at the source of supply. Any materials which have not satisfactorily passed such testing and inspection shall not be incorporated into the Work.
- E. If the manufacture of materials to be inspected or tested will occur in a plant or location greater than sixty (60) miles from the District, the Contractor shall pay for any excessive or unusual costs associated with such testing or inspection, including but not limited to excessive travel time, standby time and required lodging.
- F. Reexamination of Work may be ordered by the District. If so ordered, Work must be uncovered or deconstructed by Contractor. If Work is found to be in accordance with the Contract Documents, the District shall pay the costs of reexamination and reconstruction. If such work is found not to be in accordance with the Contract Documents, Contractor shall pay all costs.

SC-26. PROTECTION OF WORK AND PROPERTY

- A. The Contractor shall be responsible for all damages to persons or property that occurs as a result of the Work. Contractor shall be responsible for the proper care and protection of all materials delivered and Work performed until completion and final Acceptance by the District. All Work shall be solely at the Contractor's risk. Contractor shall adequately protect adjacent property from settlement or loss of lateral support as necessary. Contractor shall comply with all applicable safety laws and building codes to prevent accidents or injury to persons on, about, or adjacent to the Project site where Work is being performed. Contractor shall erect and properly maintain at all times, as required by field conditions and progress of work, all necessary safeguards, signs, barriers, lights, and watchmen for protection of workers and the public,

VALLEY-WIDE RECREATION
DIAMOND VALLEY LAKE COMMUNITY PARK
DEDICATION WALL AND PICKLEBALL COURT IMPROVEMENTS

SECTION SC-SPECIAL CONDITIONS

and shall post danger signs warning against hazards created in the course of construction.

- B. In an emergency affecting safety of life or of work or of adjoining property, Contractor, without special instruction or authorization from the Engineer, is hereby permitted to act to prevent such threatened loss or injury; and Contractor shall so act, without appeal, if so authorized or instructed by the Engineer or the District. Any compensation claimed by Contractor on account of emergency work shall be determined by and agreed upon by the District and the Contractor.

SC-27. CONTRACTOR'S MEANS AND METHODS

Contractor is solely responsible for the means and methods utilized to perform the Work. In no case shall the Contractor's means and methods deviate from commonly used industry standards.

SC-28. AUTHORIZED REPRESENTATIVES

The District shall designate representatives, who shall have the right to be present at the Project site at all times. The District may designate an inspector who shall have the right to observe all of the Contractor's Work. The inspector shall not be responsible for the Contractor's failure to carry out the Work in accordance with the Contract Documents. Contractor shall provide safe and proper facilities for such access.

SC-29. HOURS OF WORK

- A. As provided in Article 3 (commencing at section 1810), Chapter 1, Part 7, Division 2 of the Labor Code, Contractor stipulates that eight (8) hours of labor shall constitute a legal day's work. The time of service of any worker employed at any time by the Contractor or by any subcontractor on any subcontract under this Contract upon the Work or upon any part of the Work contemplated by this Contract is limited and restricted to eight (8) hours during any one calendar day and 40 hours during any one calendar week, except as hereinafter provided. Notwithstanding the provisions herein above set forth, work performed by employees of Contractor in excess of eight (8) hours per day, and 40 hours during any one week, shall be permitted upon this public work upon compensation for all hours worked in excess of eight (8) hours per day at not less than one and one-half times the basic rate of pay.
- B. The Contractor and every subcontractor shall keep an accurate record showing the name of and actual hours worked each calendar day and each calendar week by each worker employed in connection with the Work or any part of the Work contemplated by this Contract. The record shall be kept open at all reasonable hours to the inspection of the District and to the Division of Labor Law Enforcement, Department of Industrial Relations of the State of California.

VALLEY-WIDE RECREATION
DIAMOND VALLEY LAKE COMMUNITY PARK
DEDICATION WALL AND PICKLEBALL COURT IMPROVEMENTS

SECTION SC-SPECIAL CONDITIONS

- C. The Contractor shall pay to the District a penalty of twenty-five dollars (\$25.00) for each worker employed in the execution of this Contract by the Contractor or by any subcontractor for each calendar day during which such worker is required or permitted to work more than eight (8) hours in any calendar day and 40 hours in any one calendar week in violation of the provisions of Article 3 (commencing at section 1810), Chapter 1, Part 7, Division 2 of the Labor Code.
- D. Any work necessary to be performed after regular working hours, or on Saturdays and Sundays or other holidays, shall be performed without additional expense to the District.
- E. District will provide inspection during normal working hours from 7:00 a.m. to 3:30 p.m. Monday through Friday. Inspection before or after this time will be charged to the Contractor as reimbursable inspection time. Inspections on weekends requires two days' notice for review and approval. Upon written request and approval the 8.5 hour working day may be changed to other limits subject to city/county ordinance.
- F. It shall be unlawful for any person to operate, permit, use, or cause to operate any of the following at the Project site, other than between the hours of 7:00 a.m. to 5:00 p.m., Monday through Friday, with no Work allowed on the District-observed holidays, unless otherwise approved by the District:
 - 1. Powered Vehicles
 - 2. Construction Equipment
 - 3. Loading and Unloading Vehicles
 - 4. Domestic Power Tools

SC-30. PAYROLL RECORDS

- A. Pursuant to Labor Code section 1776, Contractor and all subcontractors shall maintain weekly certified payroll records, showing the names, addresses, Social Security numbers, work classifications, straight time and overtime hours worked each day and week, and the actual per diem wages paid to each journeyman, apprentice, worker, or other employee employed by them in connection with the Work under this Contract. Contractor shall certify under penalty of perjury that records maintained and submitted by Contractor are true and accurate. Contractor shall also require subcontractor(s) to certify weekly payroll records under penalty of perjury.
- B. In accordance with Labor Code section 1771.4, the Contractor and each subcontractor shall furnish the certified payroll records directly to the Department of Industrial Relations ("DIR") on the specified interval and format prescribed by the DIR, which may include electronic submission.

VALLEY-WIDE RECREATION
DIAMOND VALLEY LAKE COMMUNITY PARK
DEDICATION WALL AND PICKLEBALL COURT IMPROVEMENTS

SECTION SC-SPECIAL CONDITIONS

Contractor shall comply with all requirements and regulations from the DIR relating to labor compliance monitoring and enforcement.

- C. The payroll records described herein shall be certified and submitted by the Contractor at a time designated by the District. The Contractor shall also provide the following:
- D. A certified copy of the employee's payroll records shall be made available for inspection or furnished to such employee or his or her authorized representative on request.
- E. A certified copy of all payroll records described herein shall be made available for inspection or furnished upon request of the DIR.
- F. Unless submitted electronically, the certified payroll records shall be on forms provided by the Division of Labor Standards Enforcement ("DLSE") of the DIR or shall contain the same information as the forms provided by the DLSE.
- G. Any copy of records made available for inspection as copies and furnished upon request to the public or any public agency, the District, the Division of Apprenticeship Standards or the Division of Labor Standards Enforcement shall be marked or obliterated in such a manner as to prevent disclosure of an individual's name, address and social security number. The name and address of the Contractor awarded the Contract or performing the contract shall not be marked or obliterated.
- H. In the event of noncompliance with the requirements of this Article, the Contractor shall have ten (10) calendar days in which to comply subsequent to receipt of written notice specifying in what respects the Contractor must comply with this Article. Should noncompliance still be evident after such 10-day period, the Contractor shall pay a penalty of one hundred dollars (\$100.00) to the District for each calendar day, or portion thereof, for each worker, until strict compliance is effectuated. Upon the request of the Division of Apprenticeship Standards or the Division of Labor Standards Enforcement, such penalties shall be withheld from progress payment then due.
- I. The responsibility for compliance with this Article shall rest upon the Contractor.

SC-31. PREVAILING RATES OF WAGES

- A. The Contractor is aware of the requirements of Labor Code sections 1720 *et seq.* and 1770 *et seq.*, as well as California Code of Regulations, Title 8, Section 16000 *et seq.* ("Prevailing Wage Laws"), which require the payment of prevailing wage rates and the performance of other requirements on certain "public works" and "maintenance" projects. Since

VALLEY-WIDE RECREATION
DIAMOND VALLEY LAKE COMMUNITY PARK
DEDICATION WALL AND PICKLEBALL COURT IMPROVEMENTS

SECTION SC-SPECIAL CONDITIONS

this Project involves an applicable “public works” or “maintenance” project, as defined by the Prevailing Wage Laws, and since the total compensation is \$1,000 or more, Contractor agrees to fully comply with such Prevailing Wage Laws. The Contractor shall obtain a copy of the prevailing rates of per diem wages at the commencement of this Contract from the website of the Division of Labor Statistics and Research of the Department of Industrial Relations located at www.dir.ca.gov. In the alternative, the Contractor may view a copy of the prevailing rate of per diem wages which are on file at the District’s Administration Office and shall be made available to interested parties upon request. Contractor shall make copies of the prevailing rates of per diem wages for each craft, classification, or type of worker needed to perform work on the Project available to interested parties upon request, and shall post copies at the Contractor’s principal place of business and at the Project site. Contractor shall defend, indemnify and hold the District, its officials, officers, employees and authorized volunteers free and harmless from any claims, liabilities, costs, penalties or interest arising out of any failure or allege failure to comply with the Prevailing Wage Laws.

- B. The Contractor shall forfeit as a penalty to the District not more than Two Hundred Dollars (\$200.00), pursuant to Labor Code section 1775, for each calendar day, or portion thereof, for each worker paid less than the prevailing wage rate as determined by the Director of the Department of Industrial Relations for such work or craft in which such worker is employed for any public work done under the Contract by it or by any subcontractor under it. The difference between such prevailing wage rate and the amount paid to each worker for each calendar day or portion thereof, for which each worker was paid less than the prevailing wage rate, shall be paid to each worker by the Contractor.
- C. Contractor shall post, at appropriate conspicuous points on the Project site, a schedule showing all determined general prevailing wage rates and all authorized deductions, if any, from unpaid wages actually earned.

SC-32. PUBLIC WORKS CONTRACTOR REGISTRATION

Pursuant to Labor Code sections 1725.5 and 1771.1, the Contractor and its subcontractors must be registered with the Department of Industrial Relations prior to the execution of a contract to perform public works. By entering into this Contract, Contractor represents that it is aware of the registration requirement and is currently registered with the DIR. Contractor shall maintain a current registration for the duration of the Project. Contractor shall further include the requirements of Labor Code sections 1725.5 and 1771.1 in any subcontract and ensure that all subcontractors are registered at the time this Contract is entered into and maintain registration for the duration of the Project.

VALLEY-WIDE RECREATION
DIAMOND VALLEY LAKE COMMUNITY PARK
DEDICATION WALL AND PICKLEBALL COURT IMPROVEMENTS
SECTION SC-SPECIAL CONDITIONS

SC-33. EMPLOYMENT OF APPRENTICES

- A. Contractor and all subcontractors shall comply with the requirements of Labor Code sections 1777.5 and 1777.6 in the employment of apprentices.
- B. Information relative to apprenticeship standards, wage schedules, and other requirements may be obtained from the Director of Industrial Relations, ex officio the Administrator of Apprenticeship, San Francisco, California, or from the Division of Apprenticeship Standards and its branch offices.
- C. Knowing violations of Labor Code section 1777.5 will result in forfeiture not to exceed one hundred dollars (\$100.00) for each calendar day of non-compliance pursuant to Labor Code section 1777.7.
- D. The responsibility for compliance with this Article shall rest upon the Contractor.

SC-34. NONDISCRIMINATION/EQUAL EMPLOYMENT OPPORTUNITY

Pursuant to Labor Code section 1735 and other applicable provisions of law, the Contractor and its subcontractors shall not discriminate against any employee or applicant for employment because of race, religious creed, color, national origin, ancestry, physical disability, mental disability, medical condition, marital status, sex, age, sexual orientation, or any other classifications protected by law on this Project. The Contractor will take affirmative action to insure that employees are treated during employment or training without regard to their race, religious creed, color, national origin, ancestry, physical disability, mental disability, medical condition, marital status, sex, age, sexual orientation, or any other classifications protected by law.

1. Employment Eligibility; Contractor. By executing this Contract, Contractor verifies that it fully complies with all requirements and restrictions of state and federal law respecting the employment of undocumented aliens, including, but not limited to, the Immigration Reform and Control Act of 1986, as may be amended from time to time. Such requirements and restrictions include, but are not limited to, examination and retention of documentation confirming the identity and immigration status of each employee of the Contractor. Contractor also verifies that it has not committed a violation of any such law within the five (5) years immediately preceding the date of execution of this Contract, and shall not violate any such law at any time during the term of the Contract. Contractor shall avoid any violation of any such law during the term of this Contract by participating in an electronic verification of work authorization program operated by the United States Department of Homeland Security, by participating in an equivalent federal work authorization program operated by the United States Department of Homeland Security to verify information of newly hired employees, or by some other legally acceptable method. Contractor shall maintain records of each such verification, and shall make them available to the District or its representatives for inspection and copy at any time during normal business hours. The District shall not be responsible for

VALLEY-WIDE RECREATION
DIAMOND VALLEY LAKE COMMUNITY PARK
DEDICATION WALL AND PICKLEBALL COURT IMPROVEMENTS

SECTION SC-SPECIAL CONDITIONS

any costs or expenses related to Contractor's compliance with the requirements provided for or referred to herein.

2. Employment Eligibility; Subcontractors, Sub-subcontractors and Consultants. To the same extent and under the same conditions as Contractor, Contractor shall require all of its subcontractors, sub-subcontractors and consultants performing any part of the Work or of this Contract to make the same verifications and comply with all requirements and restrictions provided for herein.
3. Employment Eligibility; Failure to Comply. Each person executing this Contract on behalf of Contractor verifies that he or she is a duly authorized officer of Contractor, and understands that any of the following shall be grounds for the District to terminate the Contract for cause: (1) failure of Contractor or its subcontractors, sub-subcontractors or consultants to meet any of the requirements provided for herein; (2) any misrepresentation or material omission concerning compliance with such requirements; or (3) failure to immediately remove from the Work any person found not to be in compliance with such requirements.

SC-35. DEBARMENT OF CONTRACTORS AND SUBCONTRACTORS

Contractors or subcontractors may not perform work on a public works project with a subcontractor who is ineligible to perform work on a public project pursuant to Labor Code section 1777.1 or 1777.7. Any contract on a public works project entered into between a contractor and a debarred subcontractor is void as a matter of law. A debarred subcontractor may not receive any public money for performing work as a subcontractor on a public works contract. Any public money that is paid, or may have been paid to a debarred subcontractor by a contractor on the project shall be returned to the District. The Contractor shall be responsible for the payment of wages to workers of a debarred subcontractor who has been allowed to work on the project.

SC-36. LABOR/EMPLOYMENT SAFETY

The Contractor shall comply with all applicable laws and regulations of the federal, state, and local government, including Cal/OSHA requirements and requirements for verification of employees' legal right to work in the United States.

The Contractor shall maintain emergency first aid treatment for his employees which complies with the Federal Occupational Safety and Health Act of 1970 (29 U.S.C. § 651 *et seq.*), and California Code of Regulations, Title 8, Industrial Relations Division 1, Department of Industrial Relations, Chapter 4. The Contractor shall ensure the availability of emergency medical services for its employees in accordance with California Code of Regulations, Title 8, Section 1512.

The Contractor shall submit the Illness and Injury Prevention Program and a Project site specific safety program to the District prior to beginning Work at the Project site. Contractor shall maintain a confined space program that meets or exceeds the District Standards. Contractor shall adhere to the District's lock out tag out program.

VALLEY-WIDE RECREATION
DIAMOND VALLEY LAKE COMMUNITY PARK
DEDICATION WALL AND PICKLEBALL COURT IMPROVEMENTS
SECTION SC-SPECIAL CONDITIONS

SC-37. INSURANCE

The Contractor shall obtain, and at all times during performance of the Work of Contract, maintain all of the insurance described in this Article. Contractor shall not commence Work under this Contract until it has provided evidence satisfactory to the District that it has secured all insurance required hereunder. Contractor shall not allow any subcontractor to commence work on any subcontract until it has provided evidence satisfactory to the District that the subcontractor has secured all insurance required under this Article. Failure to provide and maintain all required insurance shall be grounds for the District to terminate this Contract for cause. Contractor shall furnish District with original certificates of insurance and endorsements effective coverage required by this Contract on forms satisfactory to the District. The certificates and endorsements for each insurance policy shall be signed by a person authorized by that insurer to bind coverage on its behalf, and shall be on forms acceptable to the District. All certificates and endorsements must be received and approved by the District before Work commences.

- A. **Additional Insureds; Waiver of Subrogation.** The District, its officials, officers, employees, agents and authorized volunteers shall be named as Additional Insureds on Contractor's All Risk policy and on Contractor's and its subcontractors' policies of Commercial General Liability and Automobile Liability insurance using, for Contractor's policy/ies of Commercial General Liability insurance, ISO CG forms 20 10 and 20 37 (or endorsements providing the exact same coverage, including completed operations), and, for subcontractors' policies of Commercial General Liability insurance, ISO CG form 20 38 (or endorsements providing the exact same coverage). Notwithstanding the minimum limits set forth in this Contract for any type of insurance coverage, all available insurance proceeds in excess of the specified minimum limits of coverage shall be available to the parties required to be named as Additional Insureds hereunder. Contractor and its insurance carriers shall provide a Waiver of Subrogation in favor of those parties.
- B. **Workers' Compensation Insurance.** The Contractor shall provide workers' compensation insurance for all of the employees engaged in Work under this Contract, on or at the Site, and, in case of any sublet Work, the Contractor shall require the subcontractor similarly to provide workers' compensation insurance for all the latter's employees as prescribed by State law. Any class of employee or employees not covered by a subcontractor's insurance shall be covered by the Contractor's insurance. In case any class of employees engaged in work under this Contract, on or at the Site, is not protected under the Workers' Compensation Statutes, the Contractor shall provide or shall cause a subcontractor to provide, adequate insurance coverage for the protection of such employees not otherwise protected. The Contractor is required to secure payment of compensation to his employees in accordance with the provisions of section 3700 of the Labor Code. The Contractor shall file with the District certificates of his insurance protecting workers. Company or companies providing insurance coverage shall be acceptable to the District, if in the form and coverage as set forth in the Contract Documents.
- C. **Employer's Liability Insurance.** Contractor shall provide Employer's Liability Insurance, including Occupational Disease, in the amount of at least one million dollars

VALLEY-WIDE RECREATION
DIAMOND VALLEY LAKE COMMUNITY PARK
DEDICATION WALL AND PICKLEBALL COURT IMPROVEMENTS

SECTION SC-SPECIAL CONDITIONS

(\$1,000,000.00) per person per accident. Contractor shall provide District with a certificate of Employer's Liability Insurance. Such insurance shall comply with the provisions of the Contract Documents. The policy shall be endorsed, if applicable, to provide a Borrowed Servant/Alternate Employer Endorsement and contain a Waiver of Subrogation in favor of the District.

- D. **Commercial General Liability Insurance.** Contractor shall provide "occurrence" form Commercial General Liability insurance coverage at least as broad as the most current ISO CGL Form 00 01, including but not limited to, premises liability, contractual liability, products/completed operations, personal and advertising injury which may arise from or out of Contractor's operations, use, and management of the Site, or the performance of its obligations hereunder. The policy shall not contain any exclusion contrary to this Contract including but not limited to endorsements or provisions limiting coverage for (1) contractual liability (including but not limited to ISO CG 24 26 or 21 39); or (2) cross-liability for claims or suits against one insured against another. Policy limits shall not be less than \$1,000,000 per occurrence for bodily injury, personal injury and property damage. If Commercial General Liability Insurance or other form with a general aggregate limit is used, either the general aggregate limit shall apply separately to this project/location or the general aggregate limit shall be twice the required occurrence limit. Defense costs shall be paid in addition to the limits.
- E. Such policy shall comply with all the requirements of this Article. The limits set forth herein shall apply separately to each insured against whom claims are made or suits are brought, except with respect to the limits of liability. Further the limits set forth herein shall not be construed to relieve the Contractor from liability in excess of such coverage, nor shall it limit Contractor's indemnification obligations to the District, and shall not preclude the District from taking such other actions available to the District under other provisions of the Contract Documents or law.
- F. All general liability policies provided pursuant to the provisions of this Article shall comply with the provisions of the Contract Documents.
- G. All general liability policies shall be written to apply to all bodily injury, including death, property damage, personal injury, owned and non-owned equipment, blanket contractual liability, completed operations liability, explosion, collapse, under-ground excavation, removal of lateral support, and other covered loss, however occasioned, occurring during the policy term, and shall specifically insure the performance by Contractor of that part of the indemnification contained in these General Conditions relating to liability for injury to or death of persons and damage to property.
- H. If the coverage contains one or more aggregate limits, a minimum of 50% of any such aggregate limit must remain available at all times; if over 50% of any aggregate limit has been paid or reserved, the District may require additional coverage to be purchased by Contractor to restore the required limits. Contractor may combine primary, umbrella, and as broad as possible excess liability coverage to achieve the total limits indicated above. Any umbrella or excess liability policy shall include the additional insured endorsement described in the Contract Documents.

VALLEY-WIDE RECREATION
DIAMOND VALLEY LAKE COMMUNITY PARK
DEDICATION WALL AND PICKLEBALL COURT IMPROVEMENTS

SECTION SC-SPECIAL CONDITIONS

- I. All policies of general liability insurance shall permit and Contractor does hereby waive any right of subrogation which any insurer of Contractor may acquire from Contractor by virtue of the payment of any loss.
- J. **Automobile Liability Insurance.** Contractor shall provide "occurrence" form Automobile Liability Insurance at least as broad as ISO CA 00 01 (Any Auto) in the amount of, at least, one million dollars (\$1,000,000) per accident for bodily injury and property damage. Such insurance shall provide coverage with respect to the ownership, operation, maintenance, use, loading or unloading of any auto owned, leased, hired or borrowed by Contractor or for which Contractor is responsible, in a form and with insurance companies acceptable to the District. All policies of automobile insurance shall permit and Contractor does hereby waive any right of subrogation which any insurer of Contractor may acquire from Contractor by virtue of the payment of any loss.

SC-38. FORM AND PROOF OF CARRIAGE OF INSURANCE

1. Any insurance carrier providing insurance coverage required by the Contract Documents shall be admitted to and authorized to do business in the State of California unless waived, in writing, by the District's Risk Manager. Carrier(s) shall have an A.M. Best rating of not less than an A:VII. Insurance deductibles or self-insured retentions must be declared by the Contractor. At the election of the District the Contractor shall either 1) reduce or eliminate such deductibles or self-insured retentions, or 2) procure a bond which guarantees payment of losses and related investigations, claims administration, and defense costs and expenses. If umbrella or excess liability coverage is used to meet any required limit(s) specified herein, the Contractor shall provide a "follow form" endorsement satisfactory to the District indicating that such coverage is subject to the same terms and conditions as the underlying liability policy.
2. Each insurance policy required by this Contract shall be endorsed to state that: (1) coverage shall not be suspended, voided, reduced or cancelled except after thirty (30) days prior written notice by certified mail, return receipt requested, has been given to the District; and (2) any failure to comply with reporting or other provisions of the policies, including breaches of warranties, shall not affect coverage provided to the District, its officials, officers, agents, employees, and volunteers.
3. The Certificates(s) and policies of insurance shall contain or shall be endorsed to contain the covenant of the insurance carrier(s) that it shall provide no less than thirty (30) days written notice be given to the District prior to any material modification or cancellation of such insurance. In the event of a material modification or cancellation of coverage, the District may terminate the Contract or stop the Work in accordance with the Contract Documents, unless the District receives, prior to such effective date, another properly executed original Certificate of Insurance and original copies of endorsements or certified original policies, including all endorsements and attachments thereto evidencing coverage's set forth herein and the insurance required herein is in full force and effect. Contractor shall not take possession, or use the Site, or commence operations under this Contract until the District has been furnished original Certificate(s) of Insurance and certified original copies of endorsements or policies of insurance including all endorsements and any and all other attachments as required in this Article. The original

VALLEY-WIDE RECREATION
DIAMOND VALLEY LAKE COMMUNITY PARK
DEDICATION WALL AND PICKLEBALL COURT IMPROVEMENTS
SECTION SC-SPECIAL CONDITIONS

endorsements for each policy and the Certificate of Insurance shall be signed by an individual authorized by the insurance carrier to do so on its behalf.

4. The Certificate(s) of Insurance, policies and endorsements shall so covenant and shall be construed as primary, and the District's insurance and/or deductibles and/or self-insured retentions or self-insured programs shall not be construed as contributory.
5. District reserves the right to adjust the monetary limits of insurance coverages during the term of this Contract including any extension thereof if, in the District's reasonable judgment, the amount or type of insurance carried by the Contractor becomes inadequate.
6. Contractor shall report to the District, in addition to the Contractor's insurer, any and all insurance claims submitted by the Contractor in connection with the Work under this Contract.

SC-39. TIME FOR COMPLETION AND LIQUIDATED DAMAGES

1. **Time for Completion/Liquidated Damages.** Time is of the essence in the completion of the Work. Work shall be commenced within ten (10) Days of the date stated in the District's Notice to Proceed and shall be completed by Contractor in the time specified in the Contract Documents. The District is under no obligation to consider early completion of the Project; and the Contract completion date shall not be amended by the District's receipt or acceptance of the Contractor's proposed earlier completion date. Furthermore, Contractor shall not, under any circumstances, receive additional compensation from the District (including but not limited to indirect, general, administrative or other forms of overhead costs) for the period between the time of earlier completion proposed by the Contractor and the Contract completion date. If the Work is not completed as stated in the Contract Documents, it is understood that the District will suffer damage. In accordance with Government Code section 53069.85, being impractical and infeasible to determine the amount of actual damage, it is agreed that Contractor shall pay to the District as fixed and liquidated damages, and not as a penalty, the sum stipulated in the Contract for each calendar day of delay until the Work is fully completed. Contractor and its surety shall be liable for any liquidated damages. Any money due or to become due the Contractor may be retained to cover liquidated damages.

A. **Inclement Weather.** Contractor shall abide by the Engineer's determination of what constitutes inclement weather. Time extensions for inclement weather shall only be granted when the Work stopped during inclement weather is on the critical path of the Project schedule.

B. **Extension of Time.** Contractor shall not be charged liquidated damages because of any delays in completion of the Work due to unforeseeable causes beyond the control and without the fault or negligence of Contractor (or its subcontractors or suppliers). Contractor shall within five (5) Days of identifying any such delay notify the District in writing of causes of delay. The District shall ascertain the facts and extent of delay

VALLEY-WIDE RECREATION
DIAMOND VALLEY LAKE COMMUNITY PARK
DEDICATION WALL AND PICKLEBALL COURT IMPROVEMENTS

SECTION SC-SPECIAL CONDITIONS

and grant extension of time for completing the Work when, in its judgment, the facts justify such an extension. Time extensions to the Project shall be requested by the Contractor as they occur and without delay. No delay claims shall be permitted unless the event or occurrence delays the completion of the Project beyond the Contract completion date.

- C. **No Damages for Reasonable Delay.** The District's liability to Contractor for delays for which the District is responsible shall be limited to only an extension of time unless such delays were unreasonable under the circumstances. In no case shall the District be liable for any costs which are borne by the Contractor in the regular course of business, including, but not limited to, home office overhead and other ongoing costs. Damages caused by unreasonable District delay, including delays caused by items that are the responsibility of the District pursuant to Government Code section 4215, shall be based on actual costs only, no proportions or formulas shall be used to calculate any delay damages.

SC-40. COST BREAKDOWN AND PERIODIC ESTIMATES

Contractor shall furnish on forms Approved by the District:

1. Within ten (10) Days of Notice to Proceed with the Contract, a detailed estimate giving a complete breakdown of the Contract price, if the Contract amount is a lump sum.
2. A monthly itemized estimate of Work done for the purpose of making progress payments. In order for the District to consider and evaluate each progress payment application, the Contractor shall submit a detailed measurement of Work performed and a progress estimate of the value thereof before the tenth (10th) Day of the following month.
3. Contractor shall submit, with each of its payment requests, an adjusted list of actual quantities, verified by the Engineer, for unit price items listed, if any, in the Bid Form.
4. Following the District's Acceptance of the Work, the Contractor shall submit to the District a written statement of the final quantities of unit price items for inclusion in the final payment request.
5. The District shall have the right to adjust any estimate of quantity and to subsequently correct any error made in any estimate for payment.

Contractor shall certify under penalty of perjury, that all cost breakdowns and periodic estimates accurately reflect the Work on the Project.

SC-41. PROGRESS ESTIMATES AND PAYMENT

1. By the tenth (10th) Day of the following calendar month, Contractor shall submit to Engineer a payment request which shall set forth in detail the value of the Work done for the period beginning with the date work was first commenced and ending on the end of

VALLEY-WIDE RECREATION
DIAMOND VALLEY LAKE COMMUNITY PARK
DEDICATION WALL AND PICKLEBALL COURT IMPROVEMENTS
SECTION SC-SPECIAL CONDITIONS

the calendar month for which the payment request is prepared. Contractor shall include any amount earned for authorized extra work. From the total thus computed, a deduction shall be made in the amount of five percent (5%) for retention, except where the District has adopted a finding that the Work done under the Contract is substantially complex, and then the amount withheld as retention shall be the percentage specified in the Notice Inviting Bids. From the remainder a further deduction may be made in accordance with Section B below. The amount computed, less the amount withheld for retention and any amounts withheld as set forth below, shall be the amount of the Contractor's payment request.

2. The District may withhold a sufficient amount or amounts of any payment or payments otherwise due to Contractor, as in his judgment may be necessary to cover:
 - a. Payments which may be past due and payable for just claims against Contractor or any subcontractors for labor or materials furnished in and about the performance of work on the Project under this Contract.
 - b. Defective work not remedied.
 - c. Failure of Contractor to make proper payments to his subcontractor or for material or labor.
 - d. Completion of the Contract if there is a reasonable doubt that the Work can be completed for balance then unpaid.
 - e. Damage to another contractor or a third party.
 - f. Amounts which may be due the District for claims against Contractor.
 - g. Failure of Contractor to keep the record ("as-built") drawings up to date.
 - h. Failure to provide update on construction schedule as required herein.
 - i. Site cleanup.
 - j. Failure to comply with Contract Documents.
 - k. Liquidated damages.
 - l. Legally permitted penalties.
3. The District may apply such withheld amount or amounts to payment of such claims or obligations at its discretion with the exception of subsections (B)(1), (3), and (5) of this Article, which must be retained or applied in accordance with applicable law. In so doing, the District shall be deemed the agent of Contractor and any payment so made by the District shall be considered as a payment made under contract by the District to Contractor and the District shall not be liable to Contractor for such payments made in good faith. Such payments may be made without prior judicial determination of claim or

VALLEY-WIDE RECREATION
DIAMOND VALLEY LAKE COMMUNITY PARK
DEDICATION WALL AND PICKLEBALL COURT IMPROVEMENTS

SECTION SC-SPECIAL CONDITIONS

obligations. The District will render Contractor a proper accounting of such funds disbursed on behalf of Contractor.

4. Upon receipt, the Engineer shall review the payment request to determine whether it is undisputed and suitable for payment. If the payment request is determined to be unsuitable for payment, it shall be returned to Contractor as soon as practicable but not later than seven (7) Days after receipt, accompanied by a document setting forth in writing the reasons why the payment request is not proper. The District shall make the progress payment within 30 calendar days after the receipt of an undisputed and properly submitted payment request from Contractor, provided that a release of liens and claims has been received from the Contractor pursuant to Civil Code section 8132. The number of days available to the District to make a payment without incurring interest pursuant to this paragraph shall be reduced by the number of days by which the Engineer exceeds the seven (7) Day requirement.
5. A payment request shall be considered properly executed if funds are available for payment of the payment request and payment is not delayed due to an audit inquiry by the financial officer of the District.

SC-42. SECURITIES FOR MONEY WITHHELD

Pursuant to section 22300 of the Public Contract Code of the State of California, Contractor may request the District to make retention payments directly to an escrow agent or may substitute securities for any money withheld by the District to ensure performance under the contract. At the request and expense of Contractor, securities equivalent to the amount withheld shall be deposited with the District or with a state or federally chartered bank as the escrow agent who shall return such securities to Contractor upon satisfactory completion of the contract. Deposit of securities with an escrow agent shall be subject to a written agreement substantially in the form provided in section 22300 of the Public Contract Code.

SC-43. CHANGES AND EXTRA WORK

A. Contract Change Orders.

1. The District, without invalidating the Contract, may order changes in the Work consisting of additions, deletions or other revisions, and the Contract Price and Contract Time shall be adjusted accordingly. Except as otherwise provided herein, all such changes in the Work shall be authorized by Change Order, and shall be performed under the applicable conditions of the Contract Documents. A Change Order signed by the Contractor indicates the Contractor's agreement therewith, including any adjustment in the Contract Price or the Contract Time, and the full and final settlement of all costs (direct, indirect and overhead) related to the Work authorized by the Change Order.
2. Contractor shall promptly execute changes in the Work as directed in writing by the District even when the parties have not reached agreement on whether the change increases the scope of Work or affects the Contract Price or Contract Time. All claims for additional compensation to the Contractor shall be presented in writing. No claim will be considered after the Work in question has been done unless a written Change Order has been issued or a timely written notice of claim has been made by Contractor.

VALLEY-WIDE RECREATION
DIAMOND VALLEY LAKE COMMUNITY PARK
DEDICATION WALL AND PICKLEBALL COURT IMPROVEMENTS

SECTION SC-SPECIAL CONDITIONS

3. Whenever any change is made as provided for herein, such change shall be considered and treated as though originally included in the Contract, and shall be subject to all terms, conditions, and provisions of the original Contract.
4. Contractor shall not be entitled to claim or bring suit for damages, whether for loss of profits or otherwise, on account of any decrease or omission of any item or portion of Work to be done.
5. No dispute, disagreement, or failure of the parties to reach agreement on the terms of the Change Order shall relieve the Contractor from the obligation to proceed with performance of the work, including Additional Work, promptly and expeditiously.
6. Contractor shall make available to the District any of the Contractor's documents related to the Project immediately upon request of the District, as set forth in Article 52.
7. Any alterations, extensions of time, Additional Work, or any other changes may be made without securing consent of the Contractor's surety or sureties.

B. Contract Price Change.

A. Process for Determining Adjustments in Contract Price.

- a. Owner Initiated Change. The Contractor must submit a complete cost proposal, including any change in the Contract Price or Contract Time, within seven (7) Days after receipt of a scope of a proposed change order initiated by the District, unless the District requests that proposals be submitted in less than seven (7) Days.
- b. Contractor Initiated Change. The Contractor must give written notice of a proposed change order required for compliance with the Contract Documents within seven (7) Days of discovery of the facts giving rise to the proposed change order.
- c. Whenever possible, any changes to the Contract amount shall be in a lump sum mutually agreed to by the Contractor and the District.
- d. Price quotations from the Contractor shall be accompanied by sufficiently detailed supporting documentation to permit verification by the District, including but not limited to estimates and quotations from subcontractors or material suppliers, as the District may reasonably request. Contractor shall certify the accuracy of all Change Order Requests under penalty of perjury.
- e. If the Contractor fails to submit a complete cost proposal within the seven (7) Day period (or as requested), the District has the right to order the Contractor in writing to commence the Work immediately on a time and materials basis and/or issue a lump sum change to the Contract Price and/or Contract Time in accordance with the District's estimate. If the change is issued based on the

VALLEY-WIDE RECREATION
DIAMOND VALLEY LAKE COMMUNITY PARK
DEDICATION WALL AND PICKLEBALL COURT IMPROVEMENTS
SECTION SC-SPECIAL CONDITIONS

District's estimate, the Contractor will waive its right to dispute the action unless within fifteen (15) Days following completion of the added/deleted work, the Contractor presents written proof that the District's estimate was in error.

C. Unit Price Change Orders.

1. When the actual quantity of a Unit Price item varies from the Bid Form, compensation for the change in quantity will be calculated by multiplying the actual quantity by the Unit Price. This calculation may result in either an additive or deductive Final Change Order pursuant to the Contract Documents.
2. No Mark up for Overhead and Profit. Because the Contract Unit Prices provided in the Bid Form include Overhead and Profit as determined by Contractor at the time of Bid submission, no mark up or deduction for Overhead and Profit will be included in Unit Price Change Orders.
3. Bid items included on the Bid Form may be deducted from the Work in their entirety without any negotiated extra costs.
4. Contractor acknowledges that unit quantities are estimates and agrees that the estimated unit quantities listed on the Bid Form will be adjusted to reflect the actual unit quantities which may result in an adjustment to the Contract Unit Prices. Such an adjustment will be made by execution of a final additive or deductive Change Order following Contractor's completion of the Work. Upon notification, Contractor's failure to respond within seven (7) Days will result in District's issuance of a unit quantity adjustment to the Contract Unit Prices and/or Contract Time in accordance with the Contract Documents.
5. The District or Contractor may make a Claim for an adjustment in the Unit Price in accordance with the Contract Documents if:
 6. the quantity of any item of Unit Price Work performed by Contractor differs by twenty-five percent (25%) or more from the estimated quantity of such item indicated in the Contract; and
 7. There is no corresponding adjustment with respect to any other item of Work; and
 8. Contractor believes that Contractor is entitled to an increase in Unit Price as a result of having incurred additional expense or the District believes that the District is entitled to a decrease in Unit Price and the parties are unable to agree as to the amount of any such increase or decrease.

D. Lump Sum Change Orders.

VALLEY-WIDE RECREATION
DIAMOND VALLEY LAKE COMMUNITY PARK
DEDICATION WALL AND PICKLEBALL COURT IMPROVEMENTS

SECTION SC-SPECIAL CONDITIONS

1. Compensation for Lump Sum Change Orders shall be limited to expenditures necessitated specifically by the Additional Work, and shall be segregated as follows:
2. Labor. The costs of labor will be the actual cost for wages prevailing locally for each craft or type of worker at the time the Additional Work is done, plus employer payments of payroll taxes and insurance, health and welfare, pension, vacation, apprenticeship funds, and other direct costs resulting from Federal, State or local laws, as well as assessment or benefits required by lawful collective bargaining agreements. The use of a labor classification which would increase the Additional Work cost will not be permitted unless the Contractor establishes the necessity for such new classifications. Labor costs for equipment operators and helpers shall be reported only when such costs are not included in the invoice for equipment rental.
3. Materials. The cost of materials reported shall be at invoice or lowest current price at which such materials are locally available in the quantities involved, plus sales tax, freight, and delivery. Materials costs shall be based upon supplier or manufacturer's invoice. If invoices or other satisfactory evidence of cost are not furnished within fifteen (15) Days of delivery, then the District shall determine the materials cost, at its sole discretion. Tool and Equipment Use. Costs for the use of small tools, which are tools that have a replacement value of \$1,000 or less, shall be considered included in the Overhead and Profit mark-ups established below. Regardless of ownership, the rates to be used in determining equipment use costs shall not exceed listed rates prevailing locally at equipment rental agencies, or distributors, at the time the Work is performed.

E. Time and Materials Change Orders.

1. General. The term Time and Materials means the sum of all costs reasonably and necessarily incurred and paid by Contractor for labor, materials, and equipment in the proper performance of Additional Work. Except as otherwise may be agreed to in writing by the District, such costs shall be in amounts no higher than those prevailing in the locality of the Project, and shall include only the following items.

F. Timely and Final Documentation.

1. T&M Daily Sheets. Contractor must submit timesheets, materials invoices, records of equipment hours, and records of rental equipment hours to the District's Representative for an approval signature **each day** Additional Work is performed. Failure to get the District's Representative's approval signature each Day shall result in a waiver of Contractor's right to claim these costs. The District's Representative's signature on time sheets only serves as verification that the Work was performed and is not indicative of District's agreement to Contractor's entitlement to the cost.

VALLEY-WIDE RECREATION
DIAMOND VALLEY LAKE COMMUNITY PARK
DEDICATION WALL AND PICKLEBALL COURT IMPROVEMENTS

SECTION SC-SPECIAL CONDITIONS

2. T&M Daily Summary Sheets. All documentation of incurred costs (“T&M Daily Summary Sheets”) shall be submitted by Contractor within **three (3) Days** of incurring the cost for labor, material, equipment, and special services as Additional Work is performed. Contractor’s actual costs shall be presented in a summary table in an electronic spreadsheet file by labor, material, equipment, and special services. Each T&M Daily Summary Sheet shall include Contractor’s actual costs incurred for the Additional Work performed that day and a cumulative total of Contractor’s actual costs incurred for the Additional Work. Contractor’s failure to provide a T&M Daily Summary Sheet showing a total cost summary within three (3) Days but within five (5) Days of performance of the Work will result in the Contractor’s otherwise allowable overhead and profit being reduced by 50% for that portion of Additional Work which was not documented in a timely manner. Contractor’s failure to submit the T&M Daily Summary Sheet within five (5) Days of performance of the Work will result in a total waiver of Contractor’s right to claim these costs.
3. T&M Total Cost Summary Sheet. Contractor shall submit a T&M Total Cost Summary Sheet, which shall include total actual costs, within **seven (7) Days** following completion of District approved Additional Work. Contractor’s total actual cost shall be presented in a summary table in an electronic spreadsheet file by labor, material, equipment, and special services. Contractor’s failure to submit the T&M Total Cost Summary Sheet within seven (7) Days of completion of the Additional Work will result in Contractor’s waiver for any reimbursement of any costs associated with the T&M Summary Sheets or the performance of the Additional Work.
4. Labor. The Contractor will be paid the cost of labor for the workers used in the actual and direct performance of the Work. The cost of labor will be the sum of the actual wages paid (which shall include any employer payments to or on behalf of the workers for health and welfare, pension, vacation, and similar purposes) substantiated by timesheets and certified payroll for wages prevailing for each craft or type of workers performing the Additional Work at the time the Additional Work is done, and the labor surcharge set forth in the Department of Transportation publication entitled *Labor Surcharge and Equipment Rental Rates*, which is in effect on the date upon which the Work is accomplished and which is a part of the Contract. The labor surcharge shall constitute full compensation for all payments imposed by Federal, State, or local laws and for all other payments made to, or on behalf of, the workers, other than actual wages.
5. Equipment Operator Exception. Labor costs for equipment operators and helpers shall be paid only when such costs are not included in the invoice for equipment rental.
6. Foreman Exception. The labor costs for foremen shall be proportioned to all of their assigned work and only that applicable to the Additional Work shall be

VALLEY-WIDE RECREATION
DIAMOND VALLEY LAKE COMMUNITY PARK
DEDICATION WALL AND PICKLEBALL COURT IMPROVEMENTS

SECTION SC-SPECIAL CONDITIONS

paid. Indirect labor costs, including, without limitation, the superintendent, project manager, and other labor identified in the Contract Documents will be considered Overhead.

7. Materials. The cost of materials reported shall be itemized at invoice or lowest current price at which materials are locally available and delivered to the Project site in the quantities involved, plus the cost of sales tax, freight, delivery, and storage.
8. Trade discounts available to the purchaser shall be credited to the District notwithstanding the fact that such discounts may not have been taken by Contractor.
9. For materials secured by other than a direct purchase and direct billing to the purchaser, the cost shall be deemed to be the price paid to the actual supplier as determined by the District's Representative.
10. Payment for materials from sources owned wholly or in part by the purchaser shall not exceed the price paid by the purchaser for similar materials from said sources on Additional Work items or the current wholesale price for such materials delivered to the Project site, whichever price is lower.
11. If, in the opinion of the District's Representative, the cost of materials is excessive, or Contractor does not furnish satisfactory evidence of the cost of such materials, then the cost shall be deemed to be the lowest current wholesale price for the total quantity concerned delivered to the Project site less trade discounts.
12. The District reserves the right to furnish materials for the Additional Work and no Claim shall be allowed by Contractor for costs of such materials or Indirect Costs or profit on District furnished materials.

G. Equipment.

1. Rental Time. The rental time to be paid for equipment on the Project site shall be the time the equipment is in productive operation on the Additional Work being performed and, in addition, shall include the time required to move the equipment to the location of the Additional Work and return it to the original location or to another location requiring no more time than that required to return it to its original location; except that moving time will not be paid if the equipment is used on other than the Additional Work, even though located at the site of the Additional Work.
2. Rental Time Not Allowed. Rental time will not be allowed while equipment is inoperative due to breakdowns.

VALLEY-WIDE RECREATION
DIAMOND VALLEY LAKE COMMUNITY PARK
DEDICATION WALL AND PICKLEBALL COURT IMPROVEMENTS

SECTION SC-SPECIAL CONDITIONS

3. Computation Method. The following shall be used in computing the rental time of equipment on the Project site.
4. When hourly rates are paid, any part of an hour less than 30 minutes of operation shall be considered to be 1/2-hour of operation, and any part of an hour in excess of 30 minutes will be considered one hour of operation.
5. When daily rates are paid, any part of a day less than 4 hours operation shall be considered to be 1/2-day of operation, and any part of an hour in excess of 4 hours will be considered one day of operation.

H. Rental Rates.

1. Contractor will be paid for the use of equipment at the lesser of (i) the actual rental rate, or (ii) the rental rate listed for that equipment in the California Department of Transportation publication entitled *Labor Surcharge and Equipment Rental Rates*, which is in effect on the date upon which the Contract was executed. Such rental rates will be used to compute payments for equipment whether the equipment is under Contractor's control through direct ownership, leasing, renting, or another method of acquisition. The rental rate to be applied for use of each item of equipment shall be the rate (i.e., daily, monthly) resulting in the least total cost to the District for the total period of use. If it is deemed necessary by Contractor to use equipment not listed in the publication, an equitable rental rate for the equipment will be established by the District's Representative. Contractor may furnish cost data which might assist the District's Representative in the establishment of the rental rate.

I. Contractor-Owned Equipment.

1. For Contractor-owned equipment, the allowed equipment rental rate will be limited to the monthly equipment rental rate using a utilization rate of 173 hours per month.
2. For Contractor-owned equipment, the rental time to be paid for equipment on the Site shall be the time the equipment is in productive operation, unless, in the instance of standby time, the equipment could be actively used by Contractor on another project, then District shall pay for the entirety of the time the equipment is on Site. It shall be Contractor's burden to demonstrate to the District that the equipment could be actively used on another project.
3. All equipment shall, in the opinion of the District's Representative, be in good working condition and suitable for the purpose for which the equipment is to be used.

VALLEY-WIDE RECREATION
DIAMOND VALLEY LAKE COMMUNITY PARK
DEDICATION WALL AND PICKLEBALL COURT IMPROVEMENTS

SECTION SC-SPECIAL CONDITIONS

4. Before construction equipment is used on the Additional Work, Contractor shall plainly stencil or stamp an identifying number thereon at a conspicuous location, and shall furnish to the District's Representative, in duplicate, a description of the equipment and its identifying number and the scheduled Additional Work activities planned.
5. Unless otherwise specified, manufacturer's rating and manufacturer approved modifications shall be used to classify equipment for the determination of applicable rental rates. Equipment which has no direct power unit shall be powered by a unit of at least the minimum rating recommended by the manufacturer.
6. **Special Services.** Special work or services are defined as that Additional Work characterized by extraordinary complexity, sophistication, or innovation or a combination of the foregoing attributes which are unique to the construction industry.
7. **Invoices for Special Services.** When the District's Representative and Contractor determine that a special service is required which cannot be performed by the forces of Contractor or those of any of its Subcontractors, the special service may be performed by an entity especially skilled in the Additional Work. Invoices for special services based upon the current fair market value thereof may be accepted without complete itemization of labor, material, and equipment rental costs, after validation of market values by the District's Representative.
 - a. **Discount and Allowance.** All invoices for special services will be adjusted by deducting all trade discounts offered or available, whether the discounts were taken or not. In lieu of Overhead and Profit specified herein, a total allowance not to exceed fifteen percent (15%) for Overhead and Profit will be added to invoices for Special Services.
 - b. When the District determines, in its sole discretion, that competitive bidding is necessary for certain special services, Contractor shall solicit competitive bids for those special services.
 - c. **Excluded Costs.** The term Time and Material shall not include any of the following costs or any other home or field office overhead costs, all of which are to be considered administrative costs covered by Contractor's allowance for Overhead and Profit.
 - d. **Overhead Cost.** Payroll costs and other compensation of Contractor's officers, executives, principals, general managers, engineers, architects, estimators, attorneys, auditors, accountants, purchasing and contracting agents, timekeepers, clerks, and other personnel employed by Contractor whether at the Site or in Contractor's principal office or any branch office, material yard, or shop for general administration of the Additional Work;
 - e. **Office Expenses.** Expenses of Contractor's principal and branch offices;

VALLEY-WIDE RECREATION
DIAMOND VALLEY LAKE COMMUNITY PARK
DEDICATION WALL AND PICKLEBALL COURT IMPROVEMENTS

SECTION SC-SPECIAL CONDITIONS

- f. Capital Expenses. Any part of Contractor's capital expenses, including interest on Contractor's capital employed for the Additional Work and charges against Contractor for delinquent payments;
- g. Negligence. Costs due to the negligence of Contractor or any Subcontractor or Supplier, or anyone directly or indirectly employed by any of them or for whose acts any of them may be liable, including without limitation the correction of Defective Work, disposal of materials or equipment wrongly supplied, and making good any damage to property;
- h. Other. Other overhead or general expense costs of any kind and the cost of any item not specifically and expressly included in the Contract Documents;
- i. Small Tools. Cost of small tools valued at less than \$1,000 and that remain the property of Contractor;
- j. Administrative Costs. Costs associated with the preparation of Change Orders (whether or not ultimately authorized), cost estimates, or the preparation or filing of Claims;
- k. Anticipated Lost Profits. Expenses of Contractor associated with anticipated lost profits or lost revenues, lost income or earnings, lost interest on earnings, or unpaid retention;
- l. Home Office Overhead. Costs derived from the computation of a "home office overhead" rate by application of the *Eichleay, Allegheny*, burden fluctuation, or other similar methods;
- m. Special Consultants and Attorneys. Costs of special consultants or attorneys, whether or not in the direct employ of Contractor, employed for services specifically related to the resolution of a Claim, dispute, or other matter arising out of or relating to the performance of the Additional Work.
- n. Overhead, Profit and Other Charges. The mark-up for overhead (including supervision) and profit on work added to the Contract shall be according to the following:
 - i. "Net Cost" is defined as consisting of costs of labor, materials, and tools and equipment only excluding overhead and profit. The costs of applicable insurance and bond premium will be reimbursed to the Contractor and subcontractors at cost only, without mark-up. Contractor shall provide District with documentation of the costs, including, but not limited to, payroll records, invoices, and such other information as District may reasonably request.

VALLEY-WIDE RECREATION
DIAMOND VALLEY LAKE COMMUNITY PARK
DEDICATION WALL AND PICKLEBALL COURT IMPROVEMENTS

SECTION SC-SPECIAL CONDITIONS

- ii. For Work performed by the Contractor's forces, the added cost for overhead and profit shall not exceed fifteen percent (15%) of the Net Cost of the Work.
- iii. For Work performed by a subcontractor, the added cost for overhead and profit shall not exceed fifteen percent (15%) of the subcontractor's Net Cost of the Work to which the Contractor may add five percent (5%) of the subcontractor's Net Cost.
- iv. For Work performed by a sub-subcontractor, the added cost for overhead and profit shall not exceed fifteen percent (15%) of the sub-subcontractor's Net Cost for Work to which the subcontractor and general contractor may each add an additional five percent (5%) of the Net Cost of the lower tier subcontractor.
- v. No additional mark-up will be allowed for lower tier subcontractors, and in no case shall the added cost for overhead and profit payable by District exceed twenty-five percent (25%) of the Net Cost as defined herein, of the party that performs the Work.
- o. All of the following costs are included in the markups for overhead and profit described above, and Contractor shall not receive any additional compensation for: Submittals, drawings, field drawings, Shop Drawings, including submissions of drawings; field inspection; General Superintendence; General administration and preparation of cost proposals, schedule analysis, Change Orders, and other supporting documentation; computer services; production services; Salaries of project engineer, superintendent, timekeeper, storekeeper, and secretaries; Janitorial services; Small tools, incidentals and consumables; Temporary On-Site facilities (Offices, Telephones, High Speed Internet Access, Plumbing, Electrical Power, Lighting; Platforms, Fencing, Water), Jobsite and Home office overhead or other expenses; vehicles and fuel used for work otherwise included in the Contract Documents; Surveying; Estimating; Protection of Work; Handling and disposal fees; Final Cleanup; Other Incidental Work; Related Warranties; insurance and bond premiums.
- p. For added or deducted Work by subcontractors, the Contractor shall furnish to the District the subcontractor's signed detailed record of the cost of labor, material and equipment, including the subcontractor markup for overhead and profit. The same requirement shall apply to sub-subcontractors
- q. For added or deducted work furnished by a vendor or supplier, the Contractor shall furnish to the District a detailed record of the cost to the Contractor, signed by such vendor or supplier.
- r. Any change in the Work involving both additions and deletions shall indicate a net total cost, including subcontracts and materials. Allowance for overhead

VALLEY-WIDE RECREATION
DIAMOND VALLEY LAKE COMMUNITY PARK
DEDICATION WALL AND PICKLEBALL COURT IMPROVEMENTS

SECTION SC-SPECIAL CONDITIONS

and profit, as specified herein, shall be applied if the net total cost is an increase in the Contract Price; overhead and profit allowances shall not be applied if the net total cost is a deduction to the Contract Price. The estimated cost of deductions shall be based on labor and material prices on the date the Contract was executed.

- s. Contractor shall not reserve a right to assert impact costs, extended job site costs, extended overhead, constructive acceleration and/or actual acceleration beyond what is stated in the Change Order for Work. No claims shall be allowed for impact, extended overhead costs, constructive acceleration and/or actual acceleration due to a multiplicity of changes and/or clarifications. The Contractor may not change or modify the District's change order form in an attempt to reserve additional rights.

- t. If the District disagrees with the proposal submitted by Contractor, it will notify the Contractor and the District will provide its opinion of the appropriate price and/or time extension. If the Contractor agrees with the District, a Change Order will be issued by the District. If no agreement can be reached, the District shall have the right to issue a unilateral Change Order setting forth its determination of the reasonable additions or savings in costs and time attributable to the extra or deleted work. Such determination shall become final and binding if the Contractor fails to submit a claim in writing to the District within fifteen (15) Days of the issuance of the unilateral Change Order, disputing the terms of the unilateral Change Order, and providing such supporting documentation for its position as the District may require.

J.. Change of Contract Times.

- 1. The Contract Times may only be changed by a Change Order.

- 2. All changes in the Contract Price and/or adjustments to the Contract Times related to each change shall be included in Contractor's COR pursuant to this Article. No cost or time will be allowed for cumulative effects of multiple changes. All Change Orders must state that the Contract Time is not changed or is either increased or decreased by a specific number of days. Failure to include a change to time shall waive any change to the time unless the parties mutually agree in writing to postpone a determination of the change to time resulting from the Change Order.

- 3. Notice of the amount of the request for adjustment in the Contract Times with supporting data shall be delivered within seven (7) Days after such start of occurrence, unless District's Representative allows an additional period of time to ascertain more accurate data in support of the request. No extension of time or additional compensation shall be given for a delay if the Contractor failed to give notice in the manner and within the time prescribed.

VALLEY-WIDE RECREATION
DIAMOND VALLEY LAKE COMMUNITY PARK
DEDICATION WALL AND PICKLEBALL COURT IMPROVEMENTS

SECTION SC-SPECIAL CONDITIONS

- a. District may elect, at District's sole discretion, to grant an extension in Contract Times, without Contractor's request, because of delays or other factors.
 - b. Use of Float and Critical Path.
4. Float is for the benefit of the Project. Float shall not be considered for the exclusive use or benefit of either the District or the Contractor.
5. Contractor shall not be entitled to compensation, and District will not compensate Contractor, for delays which impact early completion. Any difference in time between the Contractor's early completion and the Contract Time shall be considered a part of the Project float.
6. Contractor's entitlement to an extension of the Contract Times is limited to a District-caused extension of the critical path, reduced by the Contractor's concurrent delays, and established by a proper time impact analysis. No time extension shall be allowed unless, and then only to the extent that, the District-caused delay extends the critical path beyond the previously approved Contract Time. If approved, the increase in time required to complete the Work shall be added to the Contract Time.
7. Contractor shall not be entitled to an adjustment in the Contract Price or Contract Times for delays within the control of Contractor. Delays attributable to and within the control of a Subcontractor or Supplier shall be deemed to be delays within the control of Contractor.
8. If Contractor is delayed in the performance or progress of the Work by fire, flood, epidemic, abnormal weather conditions (as determined by the District), Acts of God, acts or failures to act of utility owners not under the control of District, or other causes not the fault of and beyond control of District and Contractor, then Contractor shall be entitled to a time extension when the Work stopped is on the critical path. Such a non-compensable adjustment shall be Contractor's sole and exclusive remedy for such delays. Contractor must submit a timely request in accordance with the requirements of this Article.
 - a. Utility-Related Delays.
9. Contractor shall immediately notify in writing the utility owner and District's Representative of its construction schedule and any subsequent changes in the construction schedule which will affect the time available for protection, removal, or relocation of utilities. Requests for extensions of time arising out of utility relocation or repair delays shall be filed in accordance with this Article.

VALLEY-WIDE RECREATION
DIAMOND VALLEY LAKE COMMUNITY PARK
DEDICATION WALL AND PICKLEBALL COURT IMPROVEMENTS

SECTION SC-SPECIAL CONDITIONS

10. Contractor shall not be entitled to damages or additional payment for delays attributable to utility relocations or alterations if correctly located, as noted in the Contract Documents or by the Underground Service Alert survey.
11. Content for Requests for Contract Extension. Contractor's justification for entitlement shall be clear and complete citing specific Contract Document references and reasons on which Contractor's entitlement is based. At a minimum, each request for a time extension must include:
 - a. Each request for an extension of Contract Time must identify the impacting event, in narrative form, providing a description of the delay event and sufficient justification as to why the Contractor is entitled to a time extension. Contractor must demonstrate that the delay arises from unforeseeable causes beyond the control and without the fault or negligence of both Contractor and any Subcontractors or Suppliers, or any other persons or organizations employed by any of them or for whose acts any of them may be liable, and that such causes in fact lead to performance or completion of the Work, or specified part in question, beyond the corresponding Contract Times, despite Contractor's reasonable and diligent actions to guard against those effects.
 - b. Each request for an extension of Contract Time must include a time impact analysis in CPM format, using the Contemporaneous Impacted As-Planned Schedule Analysis to calculate the impact of the delay event.
12. No Damages for Reasonable Delay.
 - a. District's liability to Contractor for delays for which District is responsible shall be limited to only an extension of time unless such delays were unreasonable under the circumstances. In no case shall District be liable for any costs which are borne by the Contractor in the regular course of business, including, but not limited to, home office overhead and other ongoing costs.
 - b. Damages caused by unreasonable District delay that impact the critical path, including delays caused by items that are the responsibility of the District pursuant to Government Code section 4215, shall be compensated at the Daily Rate established in the Special Conditions. No other calculations, proportions or formulas shall be used to calculate any delay damages.
 - c. District and District's Representative, and the officers, members, partners, employees, agents, consultants, or subcontractors of each of them, shall not be liable to Contractor for any claims, costs, losses,

VALLEY-WIDE RECREATION
DIAMOND VALLEY LAKE COMMUNITY PARK
DEDICATION WALL AND PICKLEBALL COURT IMPROVEMENTS

SECTION SC-SPECIAL CONDITIONS

or damages (including but not limited to all fees and charges of engineers, architects, attorneys, and other professionals and all court or arbitration or other dispute resolution costs) sustained by Contractor on or in connection with any other project or anticipated project.

- d. Contractor's failure, neglect, or refusal to comply with the requirements of the Contract Documents, or any portion thereof, shall bar Contractor's request for extensions of the Contract Times. Such failure, neglect, or refusal prejudices District's and District's Representative's ability to recognize and mitigate delay, and such failure, neglect, or refusal prevent the timely analysis of requests for extensions of Contract Times, and whether such extensions may be warranted. Contractor hereby waives all rights to extensions of Contract Times due to delays or accelerations that result from or occur during periods of time for which Contractor fails, neglects, or refuses to fully comply with the requirements of this Article.

SC-44. FINAL ACCEPTANCE AND PAYMENT

1. The acceptance of the Work on behalf of the District will be made by the Engineer. Such acceptance by the District shall not constitute a waiver of defects. When the Work has been accepted there shall be paid to Contractor a sum equal to the contract price less any amounts previously paid Contractor and less any amounts withheld by the District from Contractor under the terms of the contract. The final five percent (5%), or the percentage specified in the notice inviting bids where the District has adopted a finding of substantially complete, shall not become due and payable until five (5) calendar days shall have elapsed after the expiration of the period within which all claims may be filed under the provisions of Civil Code section 9356. If the Contractor has placed securities with the District as described herein, the Contractor shall be paid a sum equal to one hundred percent (100%) of the contract price less any amounts due the District under the terms of the Contract.
2. Unless Contractor advises the District in writing prior to acceptance of the final five percent (5%) or the percentage specified in the notice inviting bids where the District has adopted a finding of substantially complete, or the return of securities held as described herein, said acceptance shall operate as a release to the District of all claims and all liability to Contractor for all things done or furnished in connection with this work and for every act of negligence of the District and for all other claims relating to or arising out of this work. If Contractor advises the District in writing prior to acceptance of final payment or return of the securities that there is a dispute regarding the amount due the Contractor, the District may pay the undisputed amount contingent upon the Contractor furnishing a release of all undisputed claims against the District with the disputed claims in stated amounts being specifically excluded by Contractor from the operation of the release. No payments, however, final or otherwise, shall operate to release

VALLEY-WIDE RECREATION
DIAMOND VALLEY LAKE COMMUNITY PARK
DEDICATION WALL AND PICKLEBALL COURT IMPROVEMENTS
SECTION SC-SPECIAL CONDITIONS

Contractor or its sureties from the Faithful Performance Bond, Labor and Material Payment Bond, or from any other obligation under this contract.

3. In case of suspension of the contract any unpaid balance shall be and become the sole and absolute property of the District to the extent necessary to repay the District any excess in the cost of the Work above the contract price. final payment shall be made no later than 60 days after the date of acceptance of the Work by the District or the date of occupation, beneficial use and enjoyment of the Work by the District including any operation only for testing, start-up or commissioning accompanied by cessation of labor on the Work, provided that a release of liens and claims has been received from the Contractor pursuant to Civil Code section 8136. In the event of a dispute between the District and the Contractor, the District may withhold from the final payment an amount not to exceed 150% of the disputed amount.
4. Within ten (10) calendar days from the time that all or any portion of the retention proceeds are received by Contractor, Contractor shall pay each of its subcontractors from whom retention has been withheld each subcontractor's share of the retention received. However, if a retention payment received by Contractor is specifically designated for a particular subcontractor, payment of the retention shall be made to the designated subcontractor if the payment is consistent with the terms of the subcontract.

SC.45. OCCUPANCY

The District reserves the right to occupy or utilize any portion of the Work at any time before completion, and such occupancy or use shall not constitute acceptance of any part of Work covered by this Contract. This use shall not relieve the Contractor of its responsibilities under the Contract.

SC-46. INDEMNIFICATION

To the fullest extent permitted by law, Contractor shall immediately defend (with counsel of the District's choosing), indemnify and hold harmless the District, officials, officers, agents, employees, and representatives, and each of them from and against:

1. Any and all claims, demands, causes of action, costs, expenses, injuries, losses or liabilities, in law or in equity, of every kind or nature whatsoever, but not limited to, injury to or death, including wrongful death, of any person, and damages to or destruction of property of any person, arising out of, related to, or in any manner directly or indirectly connected with the Work or this Contract, including claims made by subcontractors for nonpayment, including without limitation the payment of all consequential damages and attorney's fees and other related costs and expenses, however caused, regardless of whether the allegations are false, fraudulent, or groundless, and regardless of any negligence of the District or its officers, employees, or authorized volunteers (including passive negligence), except the sole negligence or willful misconduct or active negligence of the District or its officials, officers, employees, or authorized volunteers.

VALLEY-WIDE RECREATION
DIAMOND VALLEY LAKE COMMUNITY PARK
DEDICATION WALL AND PICKLEBALL COURT IMPROVEMENTS

SECTION SC-SPECIAL CONDITIONS

2. Contractor's defense and indemnity obligation herein includes, but is not limited to damages, fines, penalties, attorney's fees and costs arising from claims under the Americans with Disabilities Act (ADA) or other federal or state disability access or discrimination laws arising from Contractor's Work during the course of construction of the improvements or after the Work is complete, as the result of defects or negligence in Contractor's construction of the improvements.
3. Any and all actions, proceedings, damages, costs, expenses, fines, penalties or liabilities, in law or equity, of every kind or nature whatsoever, arising out of, resulting from, or on account of the violation of any governmental law or regulation, compliance with which is the responsibility of Contractor;
4. Any and all losses, expenses, damages (including damages to the Work itself), attorney's fees, and other costs, including all costs of defense which any of them may incur with respect to the failure, neglect, or refusal of Contractor to faithfully perform the Work and all of Contractor's obligations under the agreement. Such costs, expenses, and damages shall include all costs, including attorney's fees, incurred by the indemnified parties in any lawsuit to which they are a party.
5. Contractor shall immediately defend, at Contractor's own cost, expense and risk, with the District Board's choosing, any and all such aforesaid suits, actions or other legal proceedings of every kind that may be brought or instituted against the District, its officials, officers, agents, employees and representatives. Contractor shall pay and satisfy any judgment, award or decree that may be rendered against the District, its officials, officers, employees, agents, employees and representatives, in any such suit, action or other legal proceeding. Contractor shall reimburse the District, its officials, officers, agents, employees and representatives for any and all legal expenses and costs incurred by each of them in connection therewith or in enforcing the indemnity herein provided. The only limitations on this provision shall be those imposed by Civil Code section 2782.

SC-47. PROCEDURE FOR RESOLVING DISPUTES

In accordance with Public Contract Code sections 20104 *et seq.* and other applicable law, public works claims of \$375,000 or less which arise between the Contractor and the District shall be resolved under the following statutory procedure unless the District has elected to resolve the dispute pursuant to Public Contract Code section 10240 *et seq.*

1. **All Claims.** All claims shall be submitted in writing and accompanied by substantiating documentation. Claims must be filed on or before the date of final payment unless other notice requirements are provided in the contract. "Claim" means a separate demand by the Contractor for (1) a time extension, (2) payment of money or damages arising from work done by or on behalf of the Contractor and payment of which is not otherwise expressly provided for or the Contractor is not otherwise entitled, or (3) an amount the payment of which is disputed by the District.

VALLEY-WIDE RECREATION
DIAMOND VALLEY LAKE COMMUNITY PARK
DEDICATION WALL AND PICKLEBALL COURT IMPROVEMENTS
SECTION SC-SPECIAL CONDITIONS

2. **Claims Under \$50,000.** The District shall respond in writing to the claim within 45 calendar days of receipt of the claim, or, the District may request, in writing, within 30 calendar days of receipt of the claim, any additional documentation supporting the claim or relating to defenses or claims the District may have. If additional information is needed thereafter, it shall be provided upon mutual agreement of the District and the Contractor. The District's written response shall be submitted 15 calendar days after receiving the additional documentation, or within the same period of time taken by the Contractor to produce the additional information, whichever is greater.
3. **Claims over \$50,000 but less than or equal to \$375,000.** The District shall respond in writing within 60 calendar days of receipt, or, may request in writing within 30 calendar days of receipt of the claim, any additional documents supporting the claim or relating to defenses or claims the District may have against the District. If additional information is needed thereafter, it shall be provided pursuant to mutual agreement between the District and the Contractor. The District response shall be submitted within 30 calendar days after receipt of the further documents, or within the same period of time taken by the Contractor to produce the additional information or documents, whichever is greater. The Contractor shall make these records and documents available at all reasonable times, without any direct charge.
4. **All Claims.** The Contractor will submit the claim justification in the following format:
 - a. Summary of claim merit and price, and Contract clause pursuant to which the claim is made.
 - b. List of documents relating to claim:
 1. Specifications
 2. Drawings
 3. Clarifications (Requests for Information)
 4. Schedules
 5. Other (All Related Documents)
 - a. Chronology of events and correspondence.
 - b. Analysis of claim merit.
 - c. Analysis of claim cost.
 - d. Analysis of time impact analysis in CPM format.
 - e. Cover letter and certification of validity of the claim.
5. **All Claims.** If the Contractor disputes the District's response, or if the District fails to respond within the statutory time period(s), the Contractor may so notify the District within 15 calendar days of the receipt of the response or the failure to respond, and demand an informal conference to meet and confer for settlement.

VALLEY-WIDE RECREATION
DIAMOND VALLEY LAKE COMMUNITY PARK
DEDICATION WALL AND PICKLEBALL COURT IMPROVEMENTS
SECTION SC-SPECIAL CONDITIONS

Upon such demand, the District shall schedule a meet and confer conference within 30 calendar days.

6. The Contractor must comply with the claims filing procedures set forth in Government Code sections 900 *et seq.* for any claim or any portion thereof that remains in dispute, after the meet and confer conference. For purposes of those provisions, the time within which a claim must be filed shall be tolled from the time the Contractor submits the written claim until the time the claim is denied, including any time utilized for the meet and confer conference. Submission of a claim, properly certified, with all required supporting documentation, and written rejection or denial of all or part of the claim by the District, is a condition precedent to any action, proceeding, litigation, suit, general conditions claim, or demand for arbitration by Contractor.
7. **Government Code Claim.** In addition to any and all contract requirements pertaining to notices of and requests for compensation or payment for extra work, disputed work, construction claims and/or changed conditions, the Contractor must comply with the claim procedures set forth in Government Code sections 900 *et seq.* prior to filing any lawsuit against the District. Such Government Code claims and any subsequent lawsuit based upon the Government Code claims shall be limited to those matters that remain unresolved after all procedures pertaining to extra work, disputed work, construction claims, and/or changed conditions have been followed by Contractor. If no such Government Code claim is submitted, or if the prerequisite contractual requirements are not otherwise satisfied as specified herein, Contractor shall be barred from bringing and maintaining a valid lawsuit against the District.

SC-48. DISTRICT'S RIGHT TO TERMINATE CONTRACT

1. Termination for Cause by the District:

- a. In the sole estimation of the District, if the Contractor refuses or fails to prosecute the Work or any separable part thereof with such diligence as will insure its completion within the time specified by the Contract Documents, or any extension thereof, or fails to complete such Work within such time, or if the Contractor should be adjudged a bankrupt, or if it should make a general assignment for the benefit of its creditors, or if a receiver should be appointed on account of its insolvency, or the Contractor or any of its subcontractors should violate any of the provisions of this Contract, the District may serve written notice upon the Contractor and its Surety of the District's intention to terminate this Contract. This notice of intent to terminate shall contain the reasons for such intention to terminate this Contract, and a statement to the effect that the Contractor's right to perform this Contract shall cease and terminate upon the expiration of ten (10) calendar days unless such violations have ceased and arrangements satisfactory to the District have been made for correction of said violations.

VALLEY-WIDE RECREATION
DIAMOND VALLEY LAKE COMMUNITY PARK
DEDICATION WALL AND PICKLEBALL COURT IMPROVEMENTS

SECTION SC-SPECIAL CONDITIONS

- b. In the event that the District serves such written notice of termination upon the Contractor and the Surety, the Surety shall have the right to take over and perform the Contract. If the Surety does not: (1) give the District written notice of Surety's intention to take over and commence performance of the Contract within 15 calendar days of the District's service of said notice of intent to terminate upon Surety; and (2) actually commence performance of the Contract within 30 calendar days of the District's service of said notice upon Surety; then the District may take over the Work and prosecute the same to completion by separate contract or by any other method it may deem advisable for the account and at the expense of the Contractor.

- c. In the event that the District elects to obtain an alternative performance of the Contract as specified above: (1) the District may, without liability for so doing, take possession of and utilize in completion of the Work such materials, appliances, plants and other property belonging to the Contractor that are on the site and reasonably necessary for such completion (A special lien to secure the claims of the District in the event of such suspension is hereby created against any property of Contractor taken into the possession of the District under the terms hereof and such lien may be enforced by sale of such property under the direction of the District Board without notice to Contractor. The proceeds of the sale after deducting all expenses thereof and connected therewith shall be credited to Contractor. If the net credits shall be in excess of the claims of the District against Contractor, the balance will be paid to Contractor or Contractor's legal representatives.); and (2) Surety shall be liable to the District for any cost or other damage to the District necessitated by the District securing an alternate performance pursuant to this Article.

2. Termination for Convenience by the District:

- a. The District may terminate performance of the Work called for by the Contract Documents in whole or, from time to time, in part, if the District determines that a termination is in the District's interest.

- b. The Contractor shall terminate all or any part of the Work upon delivery to the Contractor of a Notice of Termination specifying that the termination is for the convenience of the District, the extent of termination, and the Effective Date of such termination.

- c. After receipt of Notice of Termination, and except as directed by the District's Representative, the Contractor shall, regardless of any delay in determining or adjusting any amounts due under this Termination for Convenience clause, immediately proceed with the following obligations:
 - a. Stop Work as specified in the Notice.

VALLEY-WIDE RECREATION
DIAMOND VALLEY LAKE COMMUNITY PARK
DEDICATION WALL AND PICKLEBALL COURT IMPROVEMENTS
SECTION SC-SPECIAL CONDITIONS

- b.** Complete any Work specified in the Notice of Termination in a least cost/shortest time manner while still maintaining the quality called for under the Contract Documents.
- c.** Leave the property upon which the Contractor was working and upon which the facility (or facilities) forming the basis of the Contract Document is situated in a safe and sanitary manner such that it does not pose any threat to the public health or safety.
- d.** Terminate all subcontracts to the extent that they relate to the portions of the Work terminated.
- e.** Place no further subcontracts or orders, except as necessary to complete the continued portion of the Contract.
- f.** Submit to the District's Representative, within ten (10) calendar days from the Effective Date of the Notice of Termination, all of the usual documentation called for by the Contract Documents to substantiate all costs incurred by the Contractor for labor, materials and equipment through the Effective Date of the Notice of Termination. Any documentation substantiating costs incurred by the Contractor solely as a result of the District's exercise of its right to terminate this Contract pursuant to this clause, which costs the contractor is authorized under the Contract documents to incur, shall: (1) be submitted to and received by the Engineer no later than 30 calendar days after the Effective Date of the Notice of Termination; (2) describe the costs incurred with particularity; and (3) be conspicuously identified as "Termination Costs occasioned by the District's Termination for Convenience."
- g.** Termination of the Contract shall not relieve Surety of its obligation for any just claims arising out of or relating to the Work performed.
- h.** In the event that the District exercises its right to terminate this Contract pursuant to this clause, the District shall pay the Contractor, upon the Contractor's submission of the documentation required by this clause and other applicable provisions of the Contract Documents, the following amounts:
 - 1.** All actual reimbursable costs incurred according to the provisions of this Contract.
 - 2.** A reasonable allowance for profit on the cost of the Work performed, provided Contractor establishes to the satisfaction of the District's Representative that it is reasonably probable that Contractor would have made a profit had the Contract been completed and provided further, that the profit allowed shall in no event exceed fifteen (15%) percent of the costs.
 - 3.** A reasonable allowance for Contractor's administrative costs in determining the amount payable due to termination of the Contract under this Article.

VALLEY-WIDE RECREATION
DIAMOND VALLEY LAKE COMMUNITY PARK
DEDICATION WALL AND PICKLEBALL COURT IMPROVEMENTS

SECTION SC-SPECIAL CONDITIONS

4. Notwithstanding any other provision of this Article, when immediate action is necessary to protect life and safety or to reduce significant exposure or liability, the District may immediately order Contractor to cease Work on the Project until such safety or liability issues are addressed to the satisfaction of the District or the Contract is terminated.

SC-49. WARRANTY AND GUARANTEE OF WORK

1. Contractor hereby warrants that materials and Work shall be completed in conformance with the Contract Documents and that the materials and Work provided will fulfill the requirements of this Warranty. Contractor hereby agrees to repair or replace, at the discretion of the District, any or all Work that may prove to be defective in its workmanship, materials furnished, methods of installation or fail to conform to the Contract Document requirements together with any other Work which may be damaged or displaced by such defect(s) within a period of one (1) year from the date of the Notice of Completion of the Project without any expense whatever to the District, ordinary wear and tear and unusual abuse and neglect excepted. Contractor shall be required to promptly repair or replace defective equipment or materials, at Contractor's option. All costs associated with such corrective actions and testing, including the removal, replacement, and reinstatement of equipment and materials necessary to gain access, shall be the sole responsibility of the Contractor.
2. For any Work so corrected, Contractor's obligation hereunder to correct defective Work shall be reinstated for an additional one (1) year period, commencing with the date of acceptance of such corrected Work. The reinstatement of the one (1) year warranty shall apply only to that portion of work that was corrected. Contractor shall perform such tests as District may require to verify that any corrective actions, including, without limitation, redesign, repairs, and replacements comply with the requirements of the Contract. In the event of Contractor's failure to comply with the above-mentioned conditions within ten (10) calendar days after being notified in writing of required repairs, to the reasonable satisfaction of the District, the District shall have the right to correct and replace any defective or non-conforming Work and any work damaged by such work or the replacement or correction thereof at Contractor's sole expense. Contractor shall be obligated to fully reimburse the District for any expenses incurred hereunder immediately upon demand.
3. In addition to the warranty set forth in this Article, Contractor shall obtain for District all warranties that would be given in normal commercial practice and assign to District any and all manufacturer's or installer's warranties for equipment or materials not manufactured by Contractor and provided as part of the Work, to the extent that such third-party warranties are assignable and extend beyond the warranty period set forth in this Article. Contractor shall furnish the District with all warranty and guarantee documents prior to final Acceptance of the Project by the District as required.
4. When specifically indicated in the Contract Documents or when directed by the Engineer, the District may furnish materials or products to the Contractor for installation. In the event any act or failure to act by Contractor shall cause a warranty applicable to any materials or products purchased by the District for installation by the Contractor to

VALLEY-WIDE RECREATION
DIAMOND VALLEY LAKE COMMUNITY PARK
DEDICATION WALL AND PICKLEBALL COURT IMPROVEMENTS

SECTION SC-SPECIAL CONDITIONS

be voided or reduced, Contractor shall indemnify District from and against any cost, expense, or other liability arising therefrom, and shall be responsible to the District for the cost of any repairs, replacement or other costs that would have been covered by the warranty but for such act or failure to act by Contractor.

5. The Contractor shall remedy at its expense any damage to District-owned or controlled real or personal property.
6. The District shall notify the Contractor, in writing, within a reasonable time after the discovery of any failure, defect, or damage. The Contractor shall within ten (10) calendar days after being notified commence and perform with due diligence all necessary Work. If the Contractor fails to promptly remedy any defect, or damage; the District shall have the right to replace, repair or otherwise remedy the defect, or damage at the Contractor's expense.
7. In the event of any emergency constituting an immediate hazard to health, safety, property, or licensees, when caused by Work of the Contractor not in accordance with the Contract requirements, the District may undertake at Contractor's expense, and without prior notice, all Work necessary to correct such condition.

A. Acceptance of Defective Work.

1. If, instead of requiring correction or removal and replacement of Defective Work, the District prefers to accept it, District may do so. Contractor shall pay all claims, costs, losses, and damages (including but not limited to all fees and charges of engineers, architects, attorneys, and other professionals and all court or arbitration or other dispute resolution costs) attributable to District's evaluation of and determination to accept such Defective Work and for the diminished value of the Work.
2. If any acceptance of defective work occurs prior to release of the Project Retention, a Change Order will be issued incorporating the necessary revisions in the Contract Documents with respect to the Work, and District shall be entitled to an appropriate decrease in the Contract Price, reflecting the diminished value of Work and all costs incurred by District.
3. If the Project Retention is held in an escrow account as permitted by the Contract Documents, Contractor will promptly alert the escrow holder, in writing, of the amount of Retention to be paid to District.
4. If the acceptance of Defective Work occurs after release of the Project Retention, an appropriate amount will be paid by Contractor to District.

B. District May Correct Defective Work.

1. If Contractor fails within a reasonable time after written notice from District's Representative to correct Defective Work, or to remove and replace rejected Work as required by District, or if Contractor fails to perform the Work in accordance with the

VALLEY-WIDE RECREATION
DIAMOND VALLEY LAKE COMMUNITY PARK
DEDICATION WALL AND PICKLEBALL COURT IMPROVEMENTS

SECTION SC-SPECIAL CONDITIONS

Contract Documents, or if Contractor fails to comply with any other provision of the Contract Documents, District may, after seven (7) Days' written notice to Contractor, correct, or remedy any such deficiency.

2. In connection with such corrective or remedial action, District may exclude Contractor from all or part of the Site, take possession of all or part of the Work and suspend Contractor's services related thereto, take possession of Contractor's tools, appliances, construction equipment and machinery at the Site, and incorporate in the Work all materials and equipment stored at the Site or for which District has paid Contractor but which are stored elsewhere. Contractor shall allow District and District's Representative, and the agents, employees, other contractors, and consultants of each of them, access to the Site to enable District to exercise the rights and remedies to correct the Defective Work.
3. All claims, costs, losses, and damages (including but not limited to all fees and charges of engineers, architects, attorneys, and other professionals and all court or arbitration or other dispute resolution costs) incurred or sustained by District correcting the Defective Work will be charged against Contractor, and a Change Order will be issued incorporating the necessary revisions into the Contract Documents with respect to the Work; and District shall be entitled to an appropriate decrease in the Contract Price.
4. Such claims, costs, losses and damages will include, but not be limited to, all costs of repair, or replacement of work of others destroyed or damaged by correction, removal, or replacement of Defective Work.
5. If the Change Order is executed after all payments under the Contract have been paid by District and the Project Retention is held in an escrow account as permitted by the Contract Documents, Contractor will promptly alert the escrow holder, in writing, of the amount of Retention to be paid to District.
6. If the Change Order is executed after release of the Project Retention, an appropriate amount will be paid by Contractor to District.
7. Contractor shall not be allowed an extension of the Contract Times because of any delay in the performance of the Work attributable to District correcting Defective work.
8. Nothing in the Warranty or in the Contract Documents shall be construed to limit the rights and remedies available to District at law or in equity, including, but not limited to, Code of Civil Procedure section 337.15.

SC-50. DOCUMENT RETENTION & EXAMINATION

1. In accordance with Government Code section 8546.7, records of both the District and the Contractor shall be subject to examination and audit by the State Auditor General for a period of three (3) years after final payment.
2. Contractor shall make available to the District any of the Contractor's other documents related to the Project immediately upon request of the District.

VALLEY-WIDE RECREATION
DIAMOND VALLEY LAKE COMMUNITY PARK
DEDICATION WALL AND PICKLEBALL COURT IMPROVEMENTS

SECTION SC-SPECIAL CONDITIONS

3. In addition to the State Auditor rights above, the District shall have the right to examine and audit all books, estimates, records, contracts, documents, bid documents, subcontracts, and other data of the Contractor (including computations and projections) related to negotiating, pricing, or performing the modification in order to evaluate the accuracy and completeness of the cost or pricing data at no additional cost to the District, for a period of four (4) years after final payment.

SC-51. SEPARATE CONTRACTS

1. The District reserves the right to let other contracts in connection with this Work or on the Project site. Contractor shall permit other contractors reasonable access and storage of their materials and execution of their work and shall properly connect and coordinate its Work with theirs.
2. To ensure proper execution of its subsequent Work, Contractor shall immediately inspect work already in place and shall at once report to the Engineer any problems with the Work in place or discrepancies with the Contract Documents.
3. Contractor shall ascertain to its own satisfaction the scope of the Project and nature of any other contracts that have been or may be awarded by the District in prosecution of the Project to the end that Contractor may perform this Contract in the light of such other contracts, if any. Nothing herein contained shall be interpreted as granting to Contractor exclusive occupancy at site of the Project. Contractor shall not cause any unnecessary hindrance or delay to any other contractor working on the Project. If simultaneous execution of any contract for the Project is likely to cause interference with performance of some other contract or contracts, the Engineer shall decide which Contractor shall cease Work temporarily and which contractor shall continue or whether work can be coordinated so that contractors may proceed simultaneously. The District shall not be responsible for any damages suffered or for extra costs incurred by Contractor resulting directly or indirectly from award, performance, or attempted performance of any other contract or contracts on the Project site.

SC-52. NOTICE AND SERVICE THEREOF

All notices shall be in writing and either served by personal delivery or mailed to the other party as designated in the Bid Forms. Written notice to the Contractor shall be addressed to Contractor's principal place of business unless Contractor designates another address in writing for service of notice. Notice to District shall be addressed to the District as designated in the Notice Inviting Bids unless District designates another address in writing for service of notice. Notice shall be effective upon receipt or five (5) calendar days after being sent by first class mail, whichever is earlier. Notice given by facsimile shall not be effective unless acknowledged in writing by the receiving party.

SC-53. NOTICE OF THIRD PARTY CLAIMS

Pursuant to Public Contract Code section 9201, the District shall provide the Contractor with timely notification of the receipt of any third-party claims relating to the Contract. The District is entitled to recover reasonable costs incurred in providing such notification.

VALLEY-WIDE RECREATION
DIAMOND VALLEY LAKE COMMUNITY PARK
DEDICATION WALL AND PICKLEBALL COURT IMPROVEMENTS
SECTION SC-SPECIAL CONDITIONS

SC-54. STATE LICENSE BOARD NOTICE

Contractors are required by law to be licensed and regulated by the Contractors' State License Board which has jurisdiction to investigate complaints against contractors if a complaint regarding a patent act or omission is filed within four (4) years of the date of the alleged violation. A complaint regarding a latent act or omission pertaining to structural defects must be filed within ten (10) years of the date of the alleged violation. Any questions concerning a contractor may be referred to the Registrar, Contractors' State License Board, P.O. Box 26000, Sacramento, California 95826.

SC-55. INTEGRATION

1. **Oral Modifications Ineffective.** No oral order, objection, direction, claim or notice by any party or person shall affect or modify any of the terms or obligations contained in the Contract Documents.
2. **Contract Documents Represent Entire Contract.** The Contract Documents represent the entire agreement of the District and Contractor.

SC-56. ASSIGNMENT OF CONTRACT

Contractor shall not assign, transfer, convey, sublet or otherwise dispose of the rights or title of interest of any or all of this contract without the prior written consent of the District. Any assignment or change of Contractor's name or legal entity without the written consent of the District shall be void. Any assignment of money due or to become due under this Contract shall be subject to a prior lien for services rendered or Material supplied for performance of Work called for under the Contract Documents in favor of all persons, firms, or corporations rendering such services or supplying such Materials to the extent that claims are filed pursuant to the Civil Code, the Code of Civil Procedure or the Government Code.

SC-57. CHANGE IN NAME AND NATURE OF CONTRACTOR'S LEGAL ENTITY

Should a change be contemplated in the name or nature of the Contractor's legal entity, the Contractor shall first notify the District in order that proper steps may be taken to have the change reflected on the Contract and all related documents. No change of Contractor's name or nature will affect District's rights under the Contract, including but not limited to the bonds.

SC-58. ASSIGNMENT OF ANTITRUST ACTIONS

Pursuant to Public Contract Code section 7103.5, in entering into a public works contract or subcontract to supply goods, services, or materials pursuant to a public works contract, Contractor or subcontractor offers and agrees to assign to the District all rights, title, and interest in and to all causes of action it may have under Section 4 of the Clayton Act (15 USC, Section 15) or under the Cartwright Act (Chapter 2 (commencing with Section 16700) of Part 2 of Division 7 of the Business and Professions Code), arising from the purchase of goods, services, or materials pursuant to this contract or any subcontract. This assignment shall be made and become effective at the time the District tenders final payment to the Contractor, without further acknowledgment by the parties.

VALLEY-WIDE RECREATION
DIAMOND VALLEY LAKE COMMUNITY PARK
DEDICATION WALL AND PICKLEBALL COURT IMPROVEMENTS
SECTION SC-SPECIAL CONDITIONS

SC-59. PROHIBITED INTERESTS

No District official or representative who is authorized in such capacity and on behalf of the District to negotiate, supervise, make, accept, or approve, or to take part in negotiating, supervising, making, accepting or approving any engineering, inspection, construction or material supply contract or any subcontract in connection with construction of the project, shall be or become directly or indirectly interested financially in the Contract.

SC-60. CONTROLLING LAW

Notwithstanding any subcontract or other contract with any subcontractor, supplier, or other person or organization performing any part of the Work, this Contract shall be governed by the law of the State of California excluding any choice of law provisions.

SC-61. JURISDICTION; VENUE

Contractor and any subcontractor, supplier, or other person or organization performing any part of the Work agrees that any action or suits at law or in equity arising out of or related to the bidding, award, or performance of the Work shall be maintained in the Superior Court of Riverside County, California, and expressly consent to the jurisdiction of said court, regardless of residence or domicile, and agree that said court shall be a proper venue for any such action.

SC-62. LAWS AND REGULATIONS

1. Contractor shall give all notices and comply with all laws, ordinances, rules and regulations bearing on conduct of work as indicated and specified. If Contractor observes that drawings and specifications are at variance therewith, it shall promptly notify the Engineer in writing and any necessary changes shall be adjusted as provided for in this Contract for changes in work. If Contractor performs any work knowing it to be contrary to such laws, ordinances, rules and regulations, and without such notice to the Engineer, it shall bear all costs arising therefrom.
2. Contractor shall be responsible for familiarity with the Americans with Disabilities Act ("ADA") (42 U.S.C. § 12101 et seq.). The Work will be performed in compliance with ADA regulations.

SC-63. PATENTS

Contractor shall hold and save the District, officials, officers, employees, and authorized volunteers harmless from liability of any nature or kind of claim therefrom including costs and expenses for or on account of any patented or unpatented invention, article or appliance manufactured, furnished or used by Contractor in the performance of this contract.

SC-64. OWNERSHIP OF CONTRACT DOCUMENTS

All Contract Documents furnished by the District are District property. They are not to be used by Contractor or any subcontractor on other work nor shall Contractor claim any right to such documents. With exception of one complete set of Contract Documents, all documents shall be returned to the District on request at completion of the Work.

SC-65. NOTICE OF TAXABLE POSSESSORY INTEREST

VALLEY-WIDE RECREATION
DIAMOND VALLEY LAKE COMMUNITY PARK
DEDICATION WALL AND PICKLEBALL COURT IMPROVEMENTS
SECTION SC-SPECIAL CONDITIONS

In accordance with Revenue and Taxation Code section 107.6, the Contract Documents may create a possessory interest subject to personal property taxation for which Contractor will be responsible.

SC-66. SURVIVAL OF OBLIGATIONS

All representations, indemnifications, warranties, and guarantees made in, required by, or given in accordance with the Contract Documents, as well as all continuing obligations indicated in the Contract Documents, will survive final payment, completion, and acceptance of the Work or termination or completion of the Contract or termination of the services of Contractor.

SC-67. NOISE RESTRICTIONS

- A. Contractor shall use only such equipment on the Work and in such state of repair so that the emission of sound therefrom is within the noise tolerance level of that equipment as established by Cal/OSHA.
- B. Contractor shall comply with the most restrictive of the following: (1) local sound control and noise level rules, regulations and ordinances and (2) the requirements contained in these Contract Documents, including hours of operation requirements.
- C. No internal combustion engine shall be operated on the Project without a muffler of the type recommended by the manufacturer. Should any muffler or other control device sustain damage or be determined to be ineffective or defective, the Contractor shall promptly remove the equipment and shall not return said equipment to the job until the device is repaired or replaced. Said noise and vibration level requirements shall apply to all equipment on the job or related to the job, including but not limited to, trucks, transit mixers or transit equipment that may or may not be owned by the Contractor.

SC-68. SAFETY PROGRAM.

In addition to all other safety requirements of the Contract Documents, Contractor must comply with CalOsha at all terms during the construction until the completion of all work.

SC-69. COORDINATION WITH OTHER CONTRACTORS.

NOT USED.

SC-70. MODIFICATION OF HOURS OF WORK

[NOT USED.]

SC-71. DESIGNATION OF DISTRICT'S REPRESENTATIVE

Unless otherwise modified by District, Districts' Representative shall be Gustavo Bermeo (951)654-1505

VALLEY-WIDE RECREATION
DIAMOND VALLEY LAKE COMMUNITY PARK
DEDICATION WALL AND PICKLEBALL COURT IMPROVEMENTS
SECTION SC-SPECIAL CONDITIONS

SC-72. ENGINEER OF RECORD.

For purposes of this Project, the Engineer of Record or Engineer shall be: **James Potter LDC**

END OF SPECIAL CONDITIONS

**VALLEY-WIDE RECREATION
DIAMOND VALLEY LAKE COMMUNITY PARK
DEDICATION WALL AND PICKLEBALL COURT IMPROVEMENTS**

SECTION H - PERMITS

The Contractor shall procure all permits and licenses, including but not limited to the referenced permits in Exhibit A; the District will reimburse the Contractor of all charges, fees and taxes; and the Contractor shall give all notices necessary and incidental to the due and lawful prosecution of the work; except as follows:

Permit(s) applied for by the District and attached hereto are:

PERMITS/LICENSE

AGENCY

EXHIBIT A
VALLEY-WIDE RECREATION AND PARK DISTRICT
CITY OF HEMET PICKLEBALL COURT PERMITS

(BEHIND THIS PAGE)



INVOICE

City of Hemet

445 E. Florida Ave.
Hemet, CA 92543

APPLICANT: VALLEY-WIDE
1801 ANGLER AVE

Permit No: B1805-049
Parcel No: 454-280-024

Fee Description		Fee Amount
ENG TECH ADMIN-ENCROACH	3273-120-0238	
815 ENG TECH	3273-120-0238	\$52.70
COMMERCIAL MISC BUILDING PERMITS	2221-120-0221	
COMMERCIAL INSPECTION FEE	2221-120-0221	\$537.00
	2895-120-2019	
BUILDING STANDARDS FEE	2895-120-2019	\$4.00
COMPUTER FEE	2291-120-0291	\$7.25
MICROFILM REPRODUCTION FEE	2636-120-0636	\$49.98
PLAN STORAGE	2635-120-0635	\$16.20
TRAINING FEE COMMERCIAL	2694-120-0223	\$6.28

Total Fees Due:

\$ 673.41

Date Printed: 05/10/2018
Assessed by: NORMA HARO

CUSTOMER



INVOICE

City of Hemet

445 E. Florida Ave.
Hemet, CA 92543

APPLICANT: VALLEY-WIDE
1801 ANGLER AVE

Permit No: B1805-050
Parcel No: 454-280-024

Fee Description		Fee Amount
LANDSCAPE PLANNING	2695-120-0224	
LANDSCAPE COMMERCIAL PLANNING PERMIT	2695-120-0224	\$51.60
LANDSCAPE PLANNING PLAN REVIEW MAJOR NEW CONST	2695-120-0224	\$329.96
COMMERCIAL BASIC BUILDING PLAN REVIEW	2630-120-0630	
LANDSCAPE BUILDING PLAN REVIEW MAJOR NEW CONST	2630-120-0630	\$102.17
	2895-120-2019	
BUILDING STANDARDS FEE	2895-120-2019	\$2.00
COMPUTER FEE	2291-120-0291	\$7.25
MICROFILM REPRODUCTION FEE	2636-120-0636	\$6.00
PLAN STORAGE	2635-120-0635	\$7.20
TRAINING FEE COMMERCIAL	2694-120-0223	\$4.46

W
A

ig

A

O

P

M

B

A

T

R

C

Total Fees Due:

\$ 510.64

Date Printed: 05/10/2018
Assessed by: NORMA HARO

CUSTOMER

VALLEY-WIDE
DIAMOND VALLEY LAKE COMMUNITY PARK
MONUMENT WALL AND PICKLEBALL COURT IMPROVEMENTS

SECTION P - CONTRACT DRAWINGS

P-01. General. The location of the work, its general nature and extent, the outline of the land owned or controlled by the District and the form and general dimensions of the facilities (ie. pipelines, appurtenances, etc.) are as shown on the drawings attached and made a part of this Specification as listed below.

P-02. Construction Drawings

MONUMENT WALL

<u>Drawing No.</u>	<u>Drawing Title</u>
R-1	Site Rendering Exhibit
S-1	Construction Site Plan
L-1	Irrigation and Planting Plan
D-1	Construction Details
D-2	Irrigation Details
D-3	Planting Details

PICKLEBALL COURT IMPROVEMENTS

<u>Drawing No.</u>	<u>Drawing Title</u>
S1	Preliminary Grading Plan
LC-01	Landscape Construction Plan
LC-02	Landscape Construction Plan
IR-01	Landscape Irrigation Plan
IR-02	Landscape Irrigation Plan
PL-01	Landscape Planting Plan
PL-01	Landscape Planting Plan

LANDSCAPE PLANS FOR: DIAMOND VALLEY LAKE PARK MEMORIAL

DISTRICT:

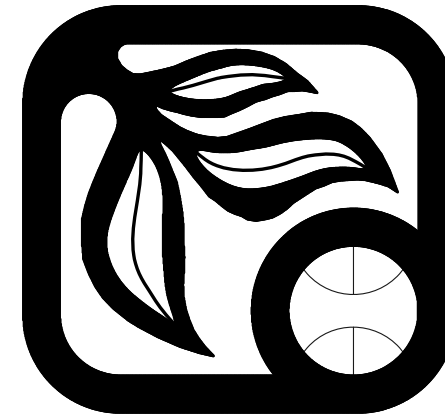

VALLEY WIDE RECREATION & PARK DISTRICT

P.O. BOX 907
901 ESPLANADE DRIVE
SAN JACINTO, CALIFORNIA 92581
TELEPHONE: (951) 654-1505

CITY:

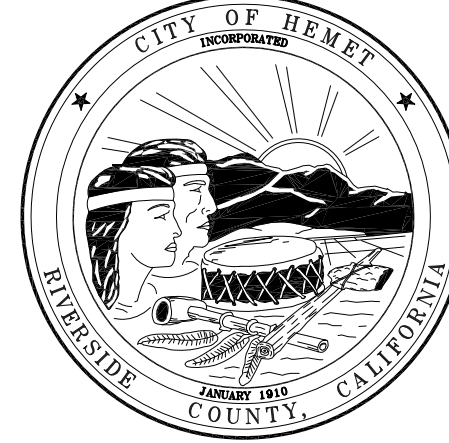

CITY OF HEMET

445 E. FLORIDA AVE.
HEMET CA 92543
SAN JACINTO, CALIFORNIA 92543
TELEPHONE: (951) 765-2300

PREPARED BY:

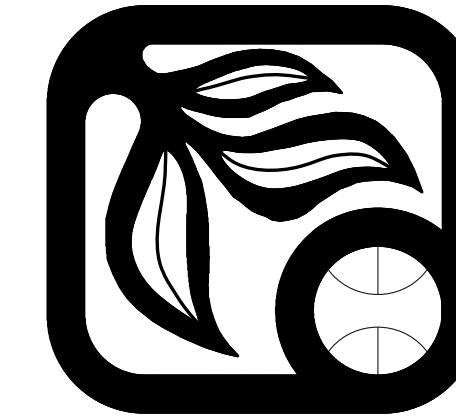

VALLEY WIDE RECREATION & PARK DISTRICT

P.O. BOX 907
901 ESPLANADE DRIVE
SAN JACINTO, CALIFORNIA 92581
TELEPHONE: (951) 654-1505

CONTACT INFO:

VALLEY-WIDE RECREATION
GENERAL MANAGER
DEAN WETTER
(951) 654-1505

VICINITY MAP:

N.T.S.

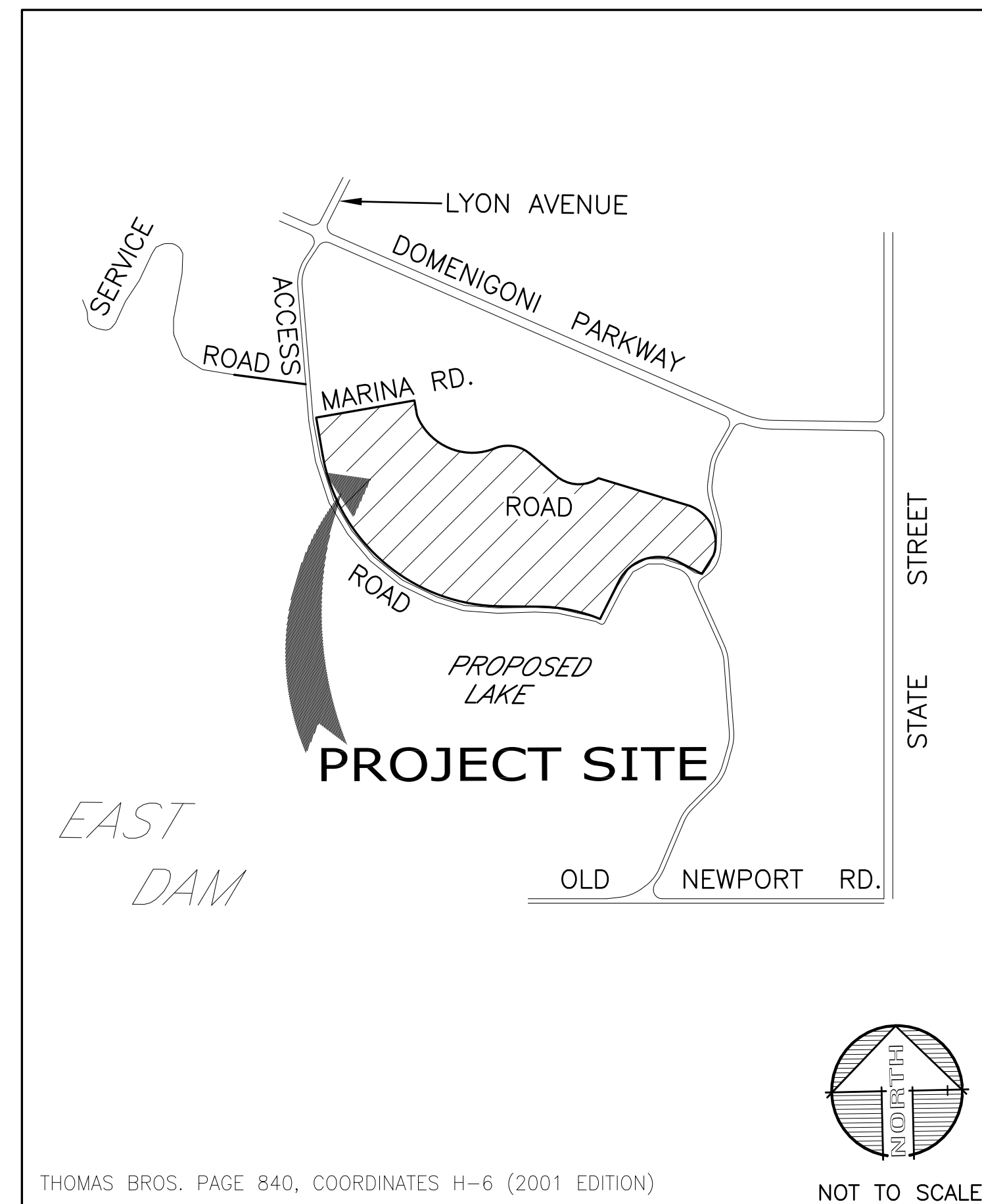

AREA MAP:

N.T.S.

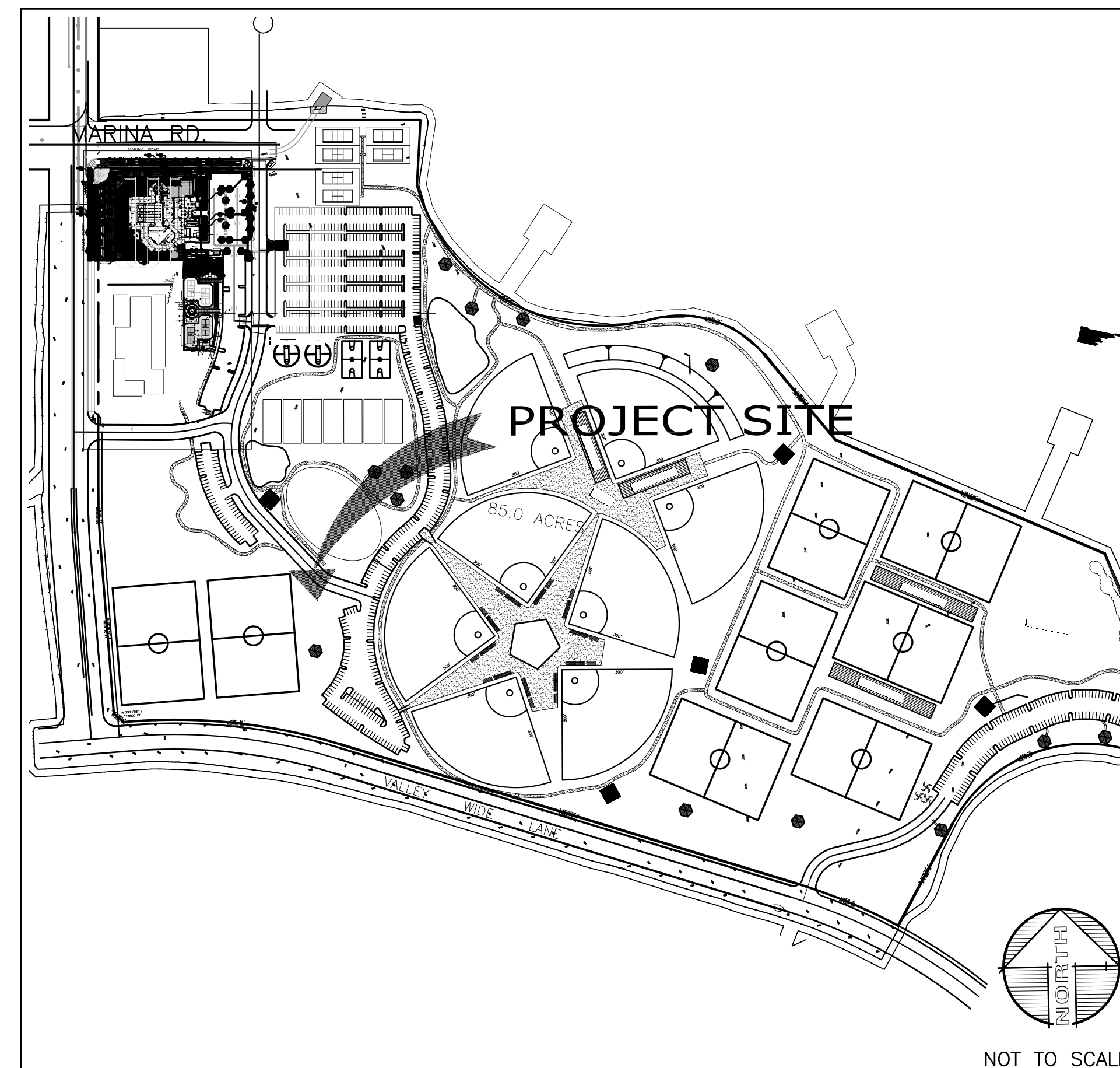

SHEET INDEX:

SHT. NO.	PAGE. NO.	DESCRIPTION
T-1	1	TITLE SHEET
R-1	2	SITE RENDERING EXHIBIT
S-1	3	CONSTRUCTION SITE PLAN
L-1	4	IRRIGATION & PLANTING PLAN
D-1	5	CONSTRUCTION DETAILS
D-2	6	IRRIGATION DETAILS
D-3	7	PLANTING DETAILS

LANDSCAPE INSPECTIONS:

PRE-CONSTRUCTION CONFERENCE	7 DAYS
CONCRETE FORMS	48 HOURS
FOOTINGS	48 HOURS
OPEN TRENCH PIPING	48 HOURS
PLANTING PITS AND MATERIAL	48 HOURS
IRRIGATION COVERAGE TEST	48 HOURS
PRE-MULCH	48 HOURS
FINAL	7 DAYS

INSPECTION LINE (951) 660-4700

ALL WORK MUST CONFORM TO VALLEY-WIDE'S CURRENT LANDSCAPE STANDARD SPECIFICATIONS AND DETAILS

AMERICANS WITH DISABILITIES NOTES

- ALL SLOPES SHOWN ON THIS PLAN WERE DESIGNED AT OR BELOW MAXIMUMS ALLOWED BY THE AMERICANS WITH DISABILITY ACT ACCESS GUIDE (A.D.A.A.G.) IN ORDER TO ALLOW FOR CONSTRUCTION TOLERANCES. IT IS THE CONTRACTOR'S RESPONSIBILITY TO FAMILIARIZE THEMSELVES WITH A.D.A.A.G. AND IN THE EVENT THAT A DESIGN QUESTION SHOULD ARISE, OR A FIELD CONDITION PRESENT ITSELF THAT IS DIFFERENT THAN SHOWN ON THESE PLANS, WORK SHOULD CEASE AND THE ENGINEER BE NOTIFIED SO THAT AN ACCEPTABLE SOLUTION CAN BE DETERMINED.
- THE CONTRACTOR IS ADVISED TO CAREFULLY CHECK ALL PHASES OF WORK RELATING TO A.D.A.A.G. ACCESS FOR THIS PROJECT. SINCE THE CODE DOES NOT ALLOW FOR A CONSTRUCTION TOLERANCE, ANY CONSTRUCTION THAT EXCEEDS MAXIMUM OR MINIMUM DIMENSIONS AND SLOPES AS CALLED OUT BY A.D.A.A.G. ARE SUBJECT TO REJECTION BY THE COUNTY AND MAY BE REQUIRED TO BE REMOVED AND REPLACED.
- SINCE THE CIVIL ENGINEER OR SURVEYOR CANNOT CONTROL THE EXACT METHODS OR MEANS USED BY THE GENERAL CONTRACTOR OR THEIR SUB-CONTRACTOR DURING GRADING AND CONSTRUCTION OF THE PROJECT, THE CIVIL ENGINEER OR SURVEYOR ASSUMES NO RESPONSIBILITY FOR FINAL ACCEPTANCE OF A.D.A.A.G. RELATED ITEMS OF THIS PROJECT BY THE COUNTY, ANY OTHER AUTHORITY OR OTHER AFFECTED PARTIES.

COMPLIANCE WITH A.D.A.A.G. CONSTRUCTION REQUIREMENTS WILL BE THE SOLE RESPONSIBILITY OF THE GENERAL CONTRACTOR AND THEIR SUB-CONTRACTORS.

HOLD HARMLESS & INDEMNIFICATION CLAUSE

CONTRACTOR AGREES TO ASSUME SOLE RESPONSIBILITY FOR JOB SITE CONDITIONS DURING THE COURSE OF CONSTRUCTION OF THIS PROJECT, INCLUDING SAFETY OF ALL PERSONS AND PROPERTY; THAT THIS REQUIREMENT SHALL APPLY CONTINUOUSLY AND NOT BE LIMITED TO NORMAL WORKING HOURS, AND THAT THE CONTRACTOR SHALL DEFEND, INDEMNIFY, AND HOLD THE OWNER/DEVELOPER, THE COUNTY OF LOCAL JURISDICTION AND THE LANDSCAPE DESIGNER HARMLESS FROM ANY AND ALL LIABILITY REAL OR ALLEGED, IN CONNECTION WITH THE PERFORMANCE OF WORK ON THIS PROJECT, EXCEPTING FOR LIABILITY ARISING FROM SOLE NEGLIGENCE OF THE OWNER/DEVELOPER, COUNTY OF LOCAL JURISDICTION AND THE LANDSCAPE DESIGNER.

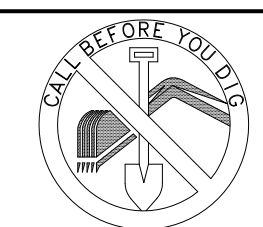

Underground Service Alert
Call: TOLL FREE
1-800-227-2600
TWO WORKING DAYS BEFORE YOU DIG

The private engineer signing these plans is responsible for assuring the accuracy and acceptability of the design hereon. In the event of discrepancies arising after city approval or during construction, the private engineer shall be responsible for determining an acceptable solution and revising the plans for approval by the City.

DATE	BY	MARK	REVISIONS	APPR.	DATE
DESIGNED BY	JP			CHECKED BY	RA
DRAWN BY	JP				

CITY OF HEMET DATE _____

R.C.E. NO. _____ EXP. DATE _____

APPROVED BY DATE _____

R.C.E. NO. _____ EXP. DATE _____



VALLEY WIDE RECREATION & PARK DISTRICT

SIGNATURE:

SAMUEL W. GOEPP

DATE

IN THE CITY OF HEMET

TITLE SHEET FOR:
**DIAMOND VALLEY LAKE
MEMORIAL WALL**

FOR VALLEY-WIDE

W.O.
0000

2-26-18

SHEET NO.

T-1

OF 7 SHTS.

FILE NO.

LESLEY ZEREBNY

FIRST RESPONDERS MEMORIAL

PROJECT AREA

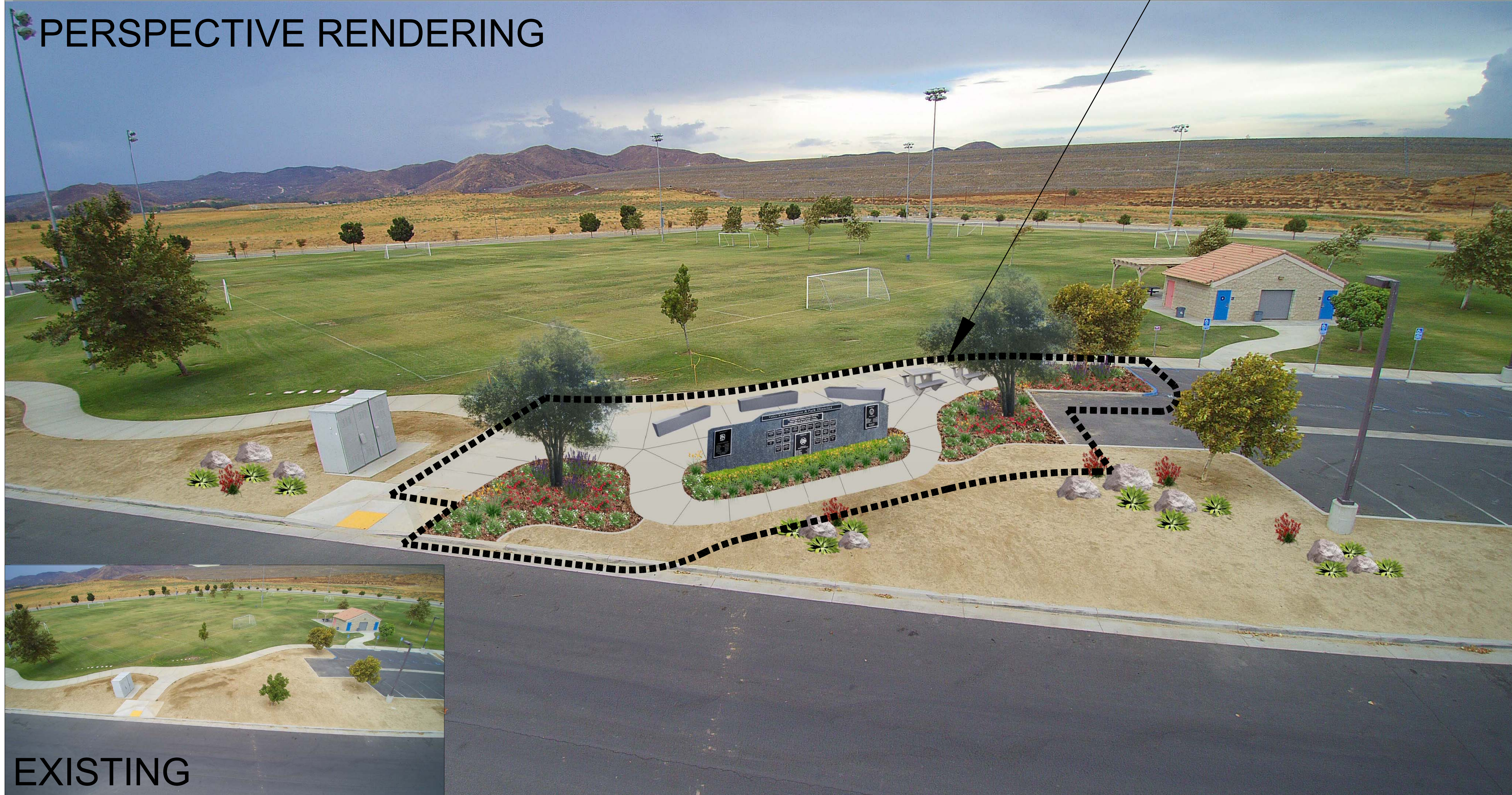

PERSPECTIVE RENDERING

EXISTING

2-26-18

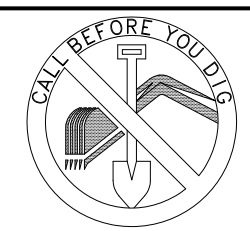

Underground Service Alert
Call: TOLL FREE
1-800-227-2600
TWO WORKING DAYS BEFORE YOU DIG

The private engineer signing these plans is responsible for assuring the accuracy and acceptability of the design hereon. In the event of discrepancies arising after city approval or during construction, the private engineer shall be responsible for determining an acceptable solution and revising the plans for approval by the City.

DATE	BY	MARK	REVISIONS	APPR.	DATE

DESIGNED BY JP DRAWN BY JP CHECKED BY RA

CITY OF HEMET DATE _____
 R.C.E. NO. _____ EXP. DATE _____
 APPROVED BY DATE _____
 RCE DATE _____
 R.C.E. NO. _____ EXP. DATE _____



VALLEY WIDE RECREATION & PARK DISTRICT
 901 W. Esplanade Ave.
 P.O. Box 907
 San Jacinto, CA 92581
 (951) 654-1505
 (951) 654-5279 FAX
 SIGNATURE: _____
 DEAN WETTER DATE _____

IN THE CITY OF HEMET
 SITE RENDERING EXHIBIT
**DIAMOND VALLEY LAKE
 MEMORIAL WALL**
 1801 MARINA DR., HEMET, CA 92545
 FOR VALLEY-WIDE W.O. 0000

SHEET NO. **R-1**
 OF 7 SHTS.
 FILE NO. _____

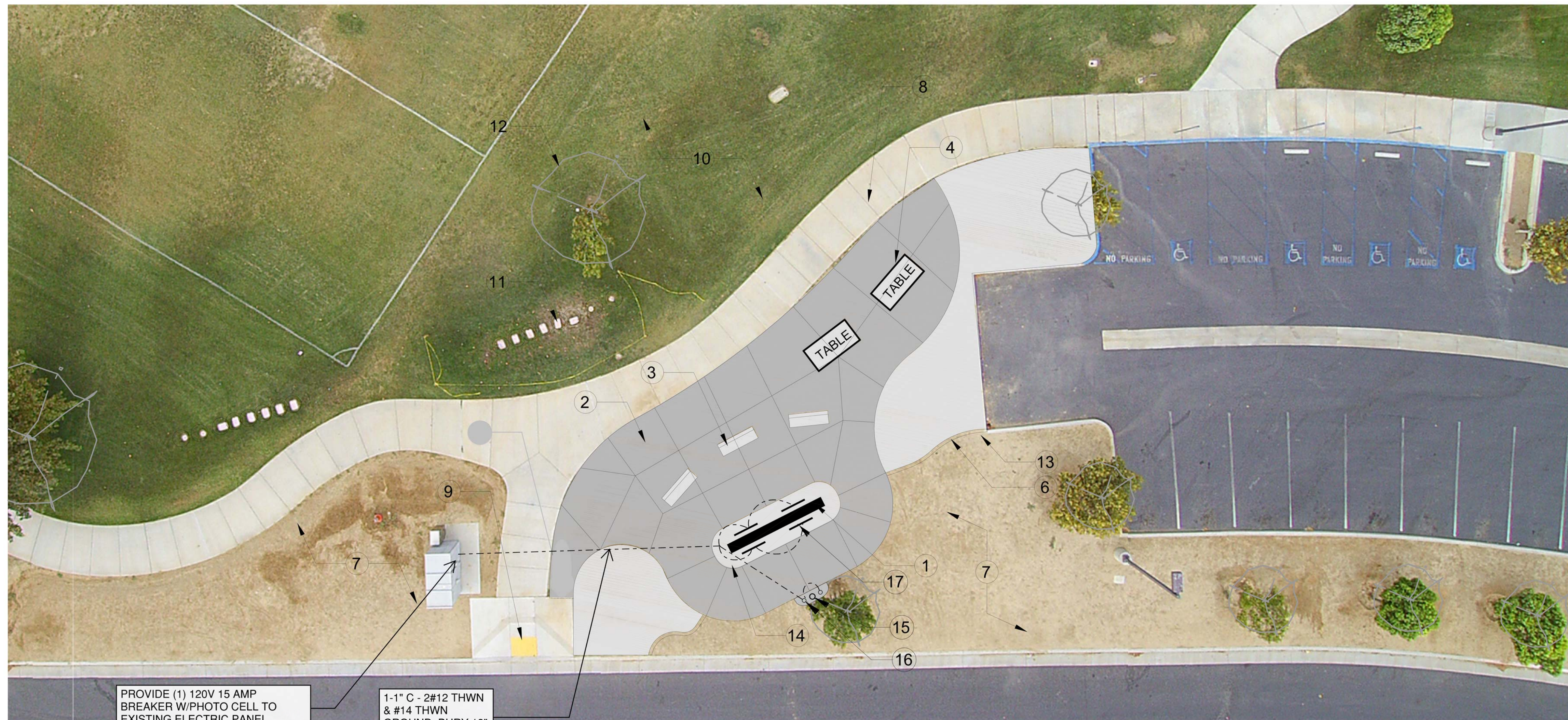

PROVIDE (1) 120V 15 AMP BREAKER W/PHOTO CELL TO EXISTING ELECTRIC PANEL

1-1" C - 2#12 THWN & #14 THWN GROUND. BURY 18" BELOW GRADE.

LEGEND

SYB	QTY.	DESCRIPTION	DETAIL # / NOTES
1	1 EA	MEMORIAL WALL, CMU WITH GRANITE OVERLAY FINAL DESIGN T.B.D.	---
2	---	NEW 4" THICK 2500 PSI CONCRETE OVER 3" THICK CLASS II BASE WITH #4 REBAR AT 4' O.C. AND DOWELS AT 4' O.C.	LC-02 & LC-03
3	3 EA	QUICKCRETE SHEAR BENCH WITHOUT BACK MODEL NO. Q2-SHR-96B-L (SLATE GRAY)	WISKATE DETERRENTS @ 5' O.C.
4	2 EA	QUICKCRETE LBT TABLE MODEL NO. QLBT102PTADA	---
5	---	NOT USED	LC-27
6	---	6X6 CONCRETE MOWCURB WITH #3 REBAR	LC-33
7	---	EXISTING DECOMPOSED GRANITE TO REMAIN IN PLACE	---
8	---	EXISTING CONCRETE SIDEWALK TO REMAIN IN PLACE	---
9	---	EXISTING ADA RAMP TO REMAIN IN PLACE	---
10	---	EXISTING GRASS TO REMAIN IN PLACE	---
11	---	EXISTING IRRIGATION VALVE TYP.	---
12	---	EXISTING TREE TO REMAIN IN PLACE	---
13	2 EA	NEW TREE T.B.D.	---
14	---	NEW PLANTER WITH PLANTS AND MULCH T.B.D.	---
15	1 EA	AH835 FLAG POLE 30' INTERNAL HALYARD EXCELL SATIN FINISH ALUMINUM WITH 6X10' AA250 NYLON US AND CALIFORNIA FLAG	PER MANUFACTURER DETAIL
16	2 EA	VISTA LIGHTING 1185-B-MF-30-A-MV-CX-ND FLAG POLE WELL LIGHT 120 VAC 14.50W EA.	PER MANUFACTURER DETAIL
17	4 EA	DABNAR LIGHTING DF-LED9410 LED LINEAR FLOOD SIGN LIGHT 120 VAC 16W EA.	PER MANUFACTURER DETAIL

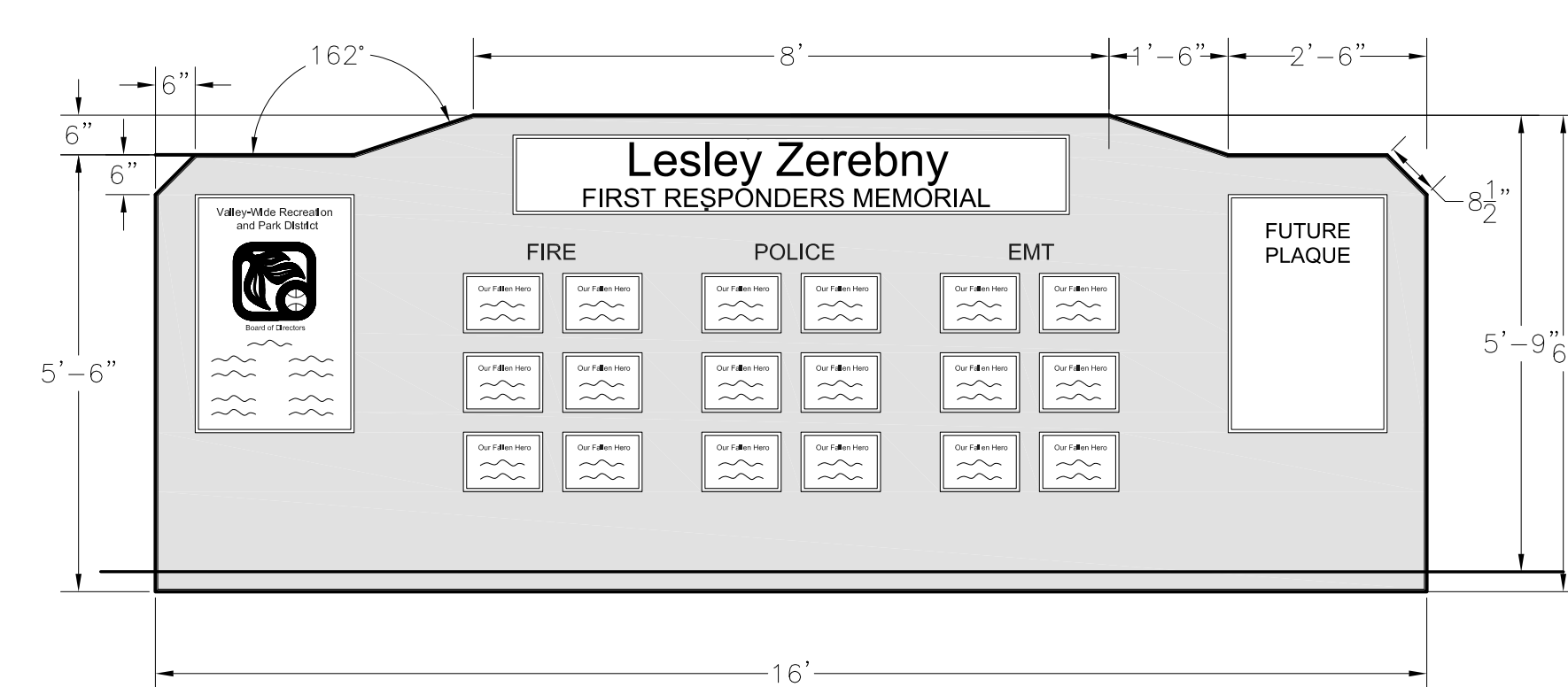
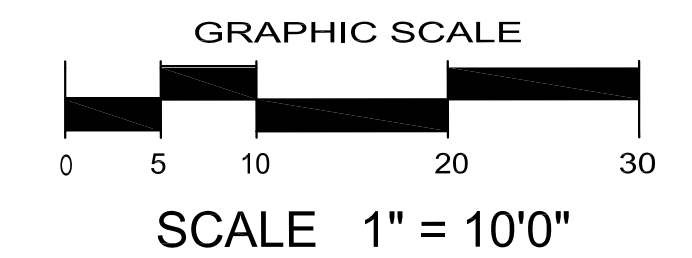
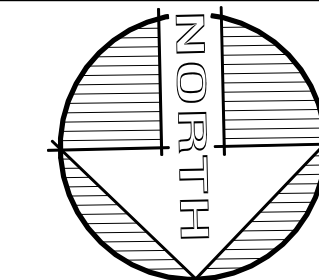

FRONT VIEW

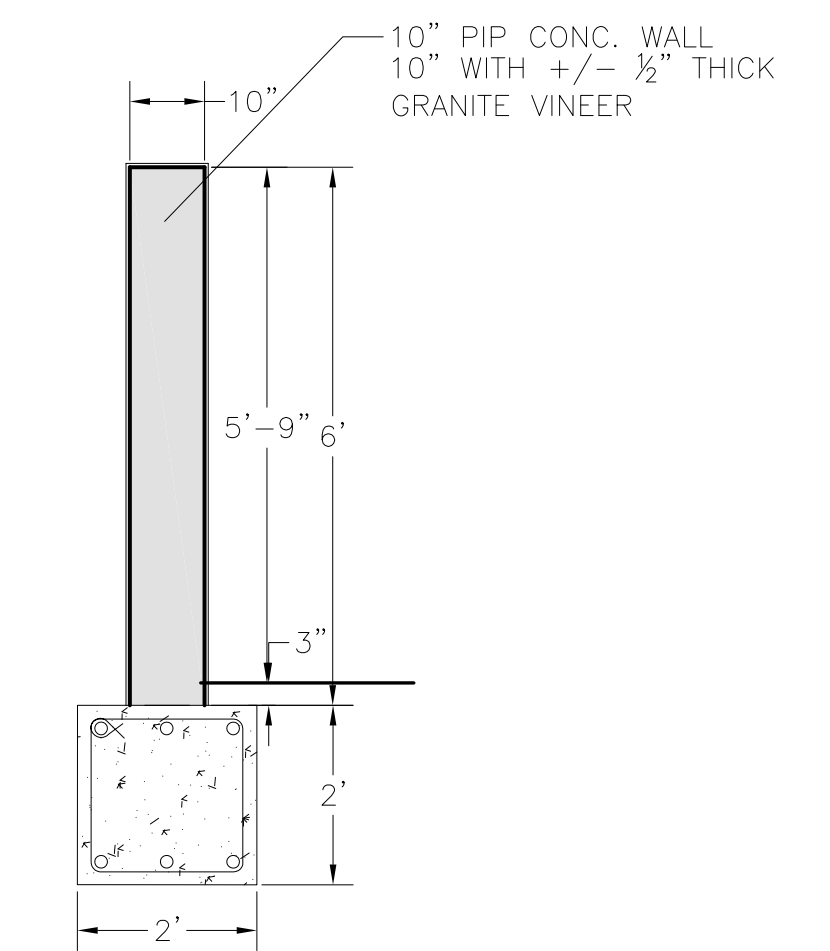

SECTION VIEW



PLAN VIEW

2-26-18

Underground Service Alert
Call: TOLL FREE
1-800-227-2600
TWO WORKING DAYS BEFORE YOU DIG

The private engineer signing these plans is responsible for assuring the accuracy and acceptability of the design hereon. In the event of discrepancies arising after city approval or during construction, the private engineer shall be responsible for determining an acceptable solution and revising the plans for approval by the City.

DATE	BY	MARK	REVISIONS	APPR.	DATE	
DESIGNED BY	JP		DRAWN BY	JP	CHECKED BY	RA

11-6-17

CITY OF HEMET DATE _____
R.C.E. NO. _____ EXP. DATE _____
APPROVED BY _____ DATE _____
R.C.E. NO. _____ EXP. DATE _____



VALLEY WIDE RECREATION & PARK DISTRICT
901 W. Esplanade Ave.
P.O. Box 907
San Jacinto, CA 92581
(951) 654-1505
(951) 654-5279 FAX

SIGNATURE: _____
DEAN WETTER DATE _____

IN THE CITY OF HEMET
CONCEPT PLAN FOR:
**DIAMOND VALLEY LAKE
MEMORIAL WALL**
1801 MARINA DR., HEMET, CA 92545
FOR VALLEY-WIDE W.O. 0000

SHEET NO. **S-1**
OF 7 SHTS.
FILE NO.

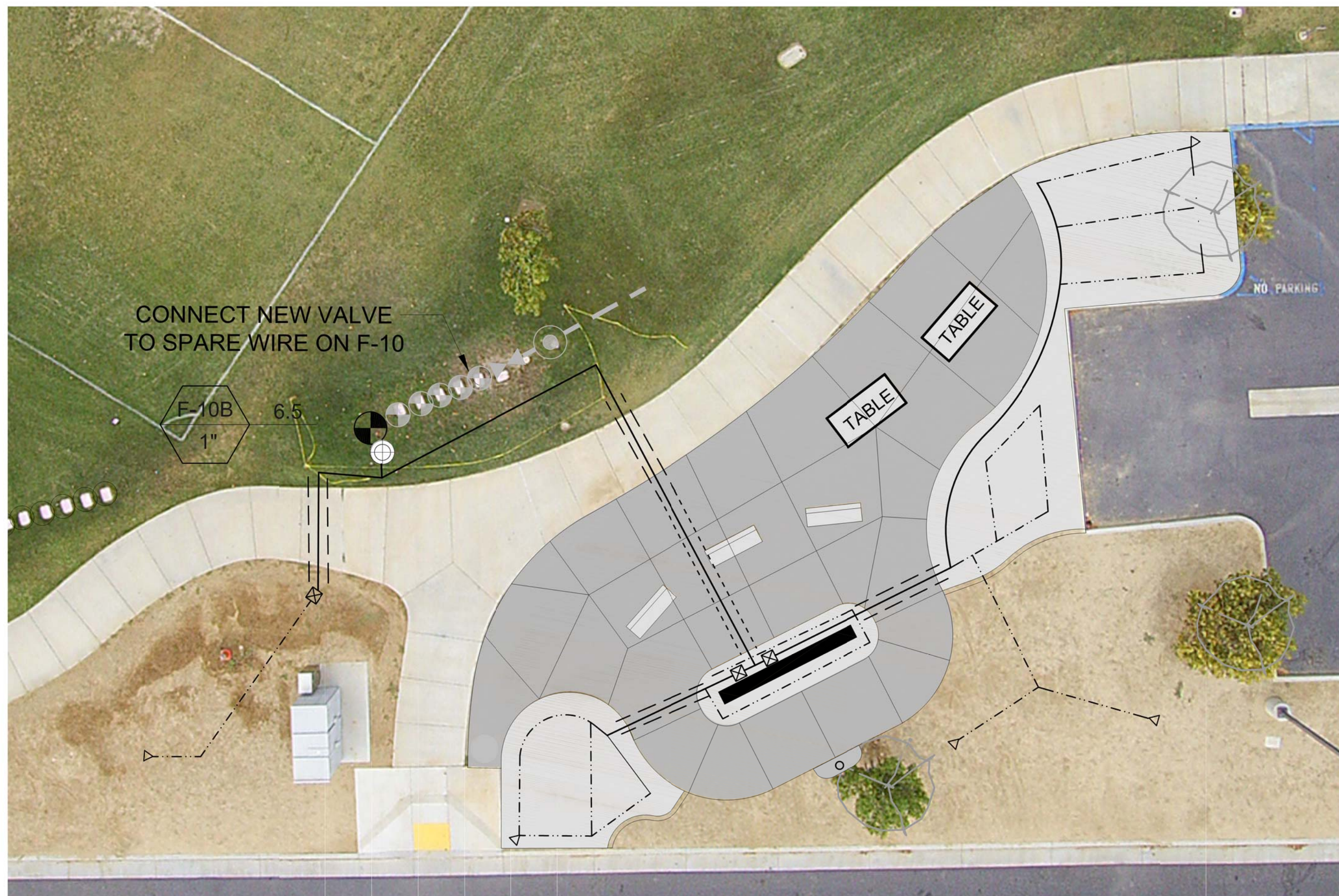
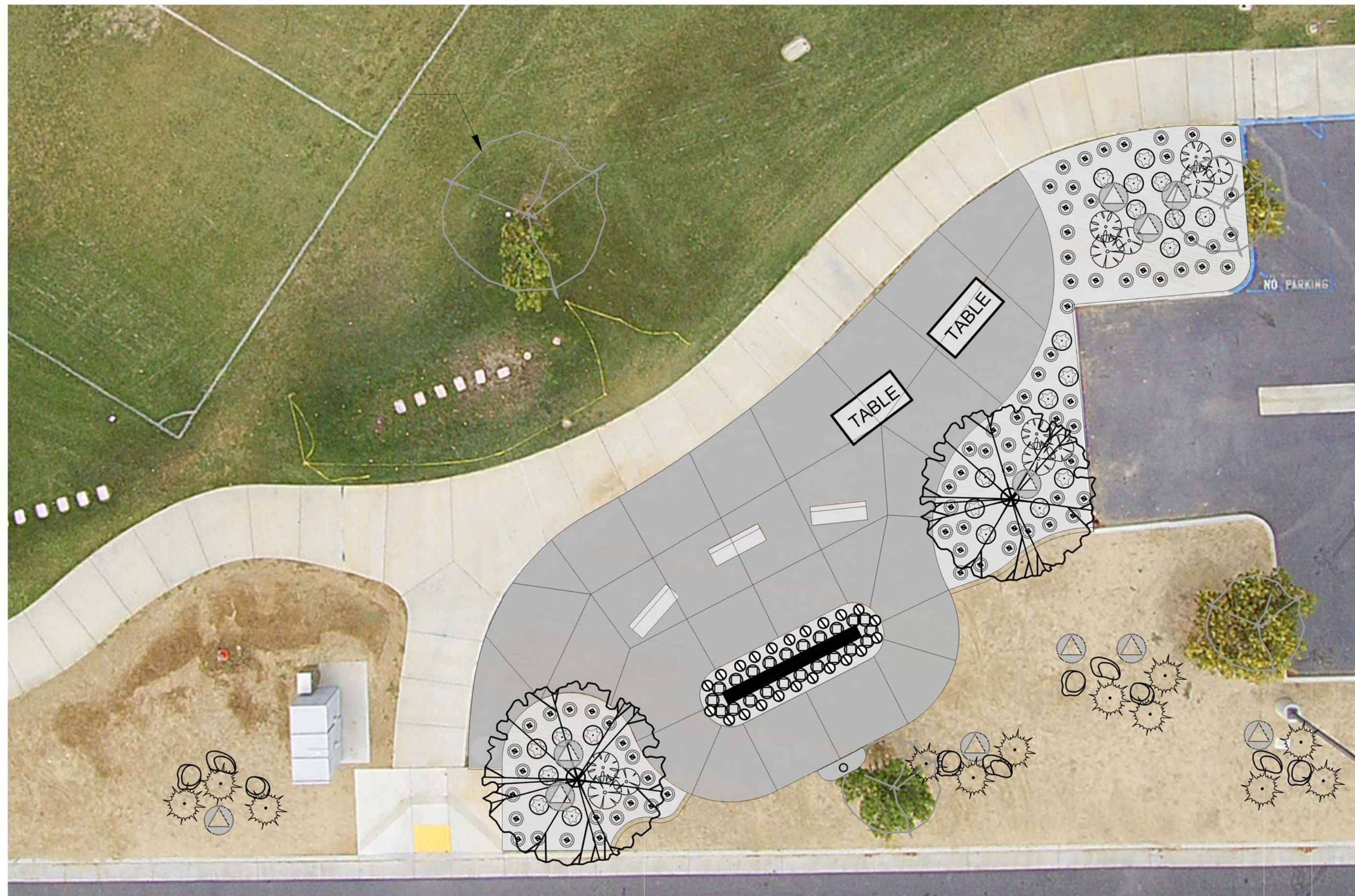

IRRIGATION LEGEND (POTABLE SYSTEM)			
SYMBOL	MAKER	MODEL NUMBER AND DESCRIPTION	DETAIL
◀	EXISTING	ISOLATION VALVE PER MAINLINE SIZE. INSTALL PER DETAILS AND REFER FOR MODEL AND TYPE AS FOLLOWS: - BRASS BALL VALVE - MODEL T-580 FOR MAINLINE 2" AND SMALLER.	IR-03 IR-04
⊙	EXISTING	QUICK COUPLING VALVE - 44DLRC W/ KEY LOCKING COVER. REFER TO IRRIGATION DETAIL AND SPECIFICATIONS.	IR-03
⊙	RAINBIRD	DRIP REMOTE CONTROL VALVE - PESB. SEE PLAN FOR SIZE. INSTALL WITH 1" RAINBIRD QUICK CHECK BASKET FILTER MODEL QK-CHK-100 W/ 200 MESH STAINLESS STEEL SCREEN. RCV'S WITH FLOWS GREATER THAN 20.1 GPM. CONTRAFCOR TO INSTALL TWO 1" FILTERS PER IRRIGATION DETAILS.	IR-02 IR-07 IR-08
⊙	EXISTING	REMOTE CONTROL VALVE, QUICK COUPLER VALVE AND ISOLATION VALVE	IR-30 IR-35
⊙	SENNINGER	PRESSURE REGULATOR - CONTRACTOR SHALL USE THE FOLLOWING MODEL NUMBERS IN CORRELATION TO DRIP RCV FLOW. SEE DETAIL. - FOR RCV'S W/ FLOW OF 0.5 TO 8 GPM CONTRACTOR SHALL INSTALL A SENNINGER PMR-30LF - FOR RCV'S W/ FLOW OF 9 TO 20 GPM CONTRACTOR SHALL INSTALL A SENNINGER PMR-30MIF - FOR RCV'S W/ FLOW OF 31 TO 32 GPM CONTRACTOR SHALL INSTALL A SENNINGER PMR-30HF	IR-30 IR-35
▶	APPROVED	DRIP FLUSH VALVE LOCATION. EACH FLUSH VALVE SHALL BE LABELED WITH ITS CORRESPONDING VALVE NUMBER FOR I.D. SEE DETAILS FOR FURTHER INFORMATION.	IR-34

IRRIGATION PIPING			
---	EXISTING	IRRIGATION MAINLINE. SLEEVE MAINLINE PER NOTES AND IRRIGATION DETAILS. FOR SIZES 1" - 1 1/2" USE POTABLE SCH. 40 PVC. SOLVENT WELD. FOR SIZES 2" - 3" USE POTABLE CLASS 315. SOLVENT WELD.	IR-23 IR-24
---	APPROVED	LATERAL PIPE - SLEEVE LATERALS PER NOTES AND IRRIGATION DETAILS. SIZE PER PLAN. - PVC SCH 40 IPS FOR LATERALS SIZES 3/4" TO 1 1/2". - PVC CLASS 315 IPS FOR LATERALS SIZES 2" AND LARGER.	IR-23
---	APPROVED	SHRUB DRIP LATERAL PIPE ON GRADE - UVR PROTECTED PIPE WITH UVR PROTECTED PVC SCH.40 FITTINGS. MINIMUM PIPE SIZE SHALL BE 3/4". PVC SCH 40 IPS LATERALS SIZES 3/4" TO 1 1/2". INSTALL WITH GPH IRRIGATION EMITTER MODEL #GSL220 PER VALLEY WIDE IRRIGATION DETAILS. CONTRACTOR SHALL INSTALL HEADER 3" OFF THE MAIN LATERAL FROM REMOTE CONTROL VALVE WITH SCH. 40 IPS PVC BURIED TO PREVENT TRIP HAZARDOUS. SIZE LATERALS PER PLAN. BURY ALL PIPE WITHIN 8" OF HARDSCAPE.	IR-30 IR-31 IR-32
---	APPROVED	TREE DRIP LATERAL PIPE ON GRADE - UVR PROTECTED PIPE WITH UVR PROTECTED PVC SCH.40 FITTINGS. MINIMUM PIPE SIZE SHALL BE 3/4". PVC SCH 40 IPS LATERALS SIZES 3/4" TO 1 1/2". INSTALL WITH GPH IRRIGATION EMITTER MODEL #GSL240 PER VALLEY WIDE IRRIGATION DETAILS. CONTRACTOR SHALL INSTALL HEADER 3" OFF THE MAIN LATERAL FROM REMOTE CONTROL VALVE WITH SCH. 40 IPS PVC BURIED TO PREVENT TRIP HAZARDOUS. SIZE LATERALS PER PLAN. BURY ALL PIPE WITHIN 8" OF HARDSCAPE.	IR-30 IR-31 IR-32 IR-33

IRRIGATION MISCELLANEOUS EQUIPMENT			
NO SYMBOL	AS APPROVED	CONTRACTOR SHALL INSTALL IRRIGATION CONTROL PILOT WIRES & EXTRA WIRES #14UF AWG DIRECT BURIAL (U.L. APPROVED). CONTRACTOR SHALL INSTALL COMMON WIRE #12UF AWG DIRECT BURIAL (U.L. APPROVED).	IR-23
NO SYMBOL	3M	DB7Y-6 DIRECT BURIAL WATER-PROOF WIRE CONNECTORS FOR USE ON ALL WIRE CONNECTIONS.	IR-28
NO SYMBOL	AS APPROVED	INSTALL THRUST BLOCK ON ALL CHANGE OF DIRECTION OF MAINLINE.	IR-24

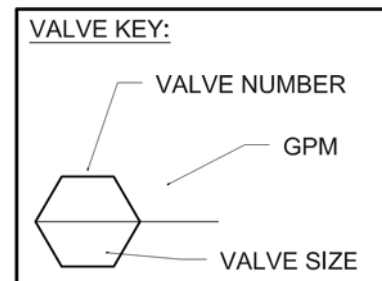

SUPPLY LATERAL PIPE SIZING:	
ZONE FLOW	PIPE SIZE
5 - 8 GPM	3/4" PVC
8.1 - 13 GPM	1" PVC
13.1 - 22 GPM	1 1/4" PVC
22.1 - 30 GPM	1 1/2" PVC

IRRIGATION POINT-OF-CONNECTION NOTES:

CONNECT NEW VALVE TO EXISTING 4" RECYCLED WATER MAINLINE, PROVIDED AND INSTALLED BY OTHERS.

VERIFY EXISTING IRRIGATION CONTROLLER CAN HOUSE ALL EXISTING EXTRA WIRES BEFORE COMMENCEMENT OF THE PROJECT. OTHERWISE IMMEDIATELY CONTACT THE LANDSCAPE DESIGNER FOR ADDITIONAL DIRECTIVE.

OBSERVATION SCHEDULE

THE LANDSCAPE CONTRACTOR SHALL BE RESPONSIBLE TO SCHEDULE AN IRRIGATION OBSERVATION REVIEW BY VALLEY WIDE FOR THE FOLLOWING ITEMS:

- * PRE-JOB
- * MAINLINE LAYOUT, FILTER/BASKET STRAINER, QUICK COUPLERS, REMOTE CONTROL VALVES AND WIRES PRIOR TO BACKFILLING TRENCHES, AND MAINLINE PRESSURE TEST.

IRRIGATION MAINLINE

THE IRRIGATION MAINLINE IS SHOWN DIAGRAMMATIC FOR CLARITY PURPOSE ONLY. ALL IRRIGATION MAINLINE SHALL BE STAKED/ CHALKED IN THE FIELD FOR REVIEW AND APPROVAL BY THE OWNER'S REPRESENTATIVE PRIOR TO INSTALLATION.

INSTALLATION NOTE

THE CONTRACTOR SHALL REFER TO THE LATEST EDITION OF THE VALLEY-WIDE RECREATION AND PARK DISTRICT STANDARDS MANUAL AND DESIGN GUIDELINES. REFER TO IRRIGATION DETAILS AND NOTES FOR ADDITIONAL INFORMATION.

PLANTING LEGEND					
SYMBOL	QTY.	SIZE	BOTANICAL NAME	COMMON NAME	WATER
⊙	2	36" BOX	QUERCUS VIRGINIANA	SOUTHERN OAK	LOW
⊙	12	15 GAL.	AGAVE ATTENUATA	FOX TAIL AGAVE	MED
⊙	12	5 GAL.	WESTRINGIA FRUTICOSA	COASTAL ROSEMARY	MED
⊙	22	5 GAL.	SALVIA LEUCANTHA	MEXICAN SAGE	MED
⊙	11	5 GAL.	HESPERALOE PARVIFLORA	RED YUCCA	LOW
⊙	87	1 GAL.	ROSMARINUS OFFICINALIS	TRAILING ROSEMARY	LOW
⊙	22	1 GAL.	TULHBAGIA VIOLACEA	SOCIETY GARLIC	MED
⊙	24	5 GAL.	BUXUS JAPONICA	JAPANESE BOXWOOD	MED
⊙	PER PLAN	4" THICK	BARK MULCH	APPROVED BY VWRPD	
⊙	PER PLAN	3'-4'	TAN LANDSCAPE BOULDER		

- NOTES**
- ALL WORK MUST CONFORM TO VALLEY-WIDE'S CURRENT LANDSCAPE STANDARDS.
 - CONTRACTOR SHALL VERIFY ALL QUANTITIES ON PLAN WITH LEGEND.
 - PROVIDE ROOT BARRIER FOR ALL TREES WITHIN 8' OF HARDSCAPE PER DETAIL PL-9.
 - MULCH SAMPLES MUST BE APPROVED BY VALLEY-WIDE PRIOR TO INSTALLATION.
 - CONTRACTOR SHALL CALL FOR THE FOLLOWING INSPECTIONS:
 - FINISH GRADE PRIOR TO PLANTING
 - SOIL PREPARATION
 - WEEDABATEMENT OBSERVATION
 - TREE & SHRUB LAYOUT
 - GRADE PRIOR TO HYDROSEEDING
 - COMPLETION (MAINT. START)
 - MONTHLY MAINT. WALK
 - FINAL WALK
- VALLEY-WIDE INSPECTION DEPT.
CALL (951) 660-4700
- 48 HOUR NOTICE FOR INSPECTIONS
7 DAY NOTICE FOR FINAL WALK.



Underground Service Alert
Call: TOLL FREE
1-800-227-2600
TWO WORKING DAYS BEFORE YOU DIG

The private engineer signing these plans is responsible for assuring the accuracy and acceptability of the design hereon. In the event of discrepancies arising after city approval or during construction, the private engineer shall be responsible for determining an acceptable solution and revising the plans for approval by the City.

DATE	BY	MARK	REVISIONS	APPR.	DATE
DESIGNED BY	JP	DRAWN BY	JP	CHECKED BY	RA

CITY OF HEMET	DATE
R.C.E. NO.	EXP. DATE
APPROVED BY	DATE
R.C.E. NO.	EXP. DATE

VALLEY WIDE RECREATION & PARK DISTRICT
901 W. Esplanade Ave.
P.O. Box 907
San Jacinto, CA 92581
(951) 654-1505
(951) 654-5279 FAX

SIGNATURE: _____
DEAN WETTER

DATE: _____

IN THE CITY OF HEMET
IRRIGATION & PLANTING PLAN FOR:
**DIAMOND VALLEY LAKE
MEMORIAL WALL**
1801 MARINA DR., HEMET, CA 92545

FOR VALLEY-WIDE

SHEET NO. **L-1**
OF 7 SHTS.
FILE NO.

W.O. 0000

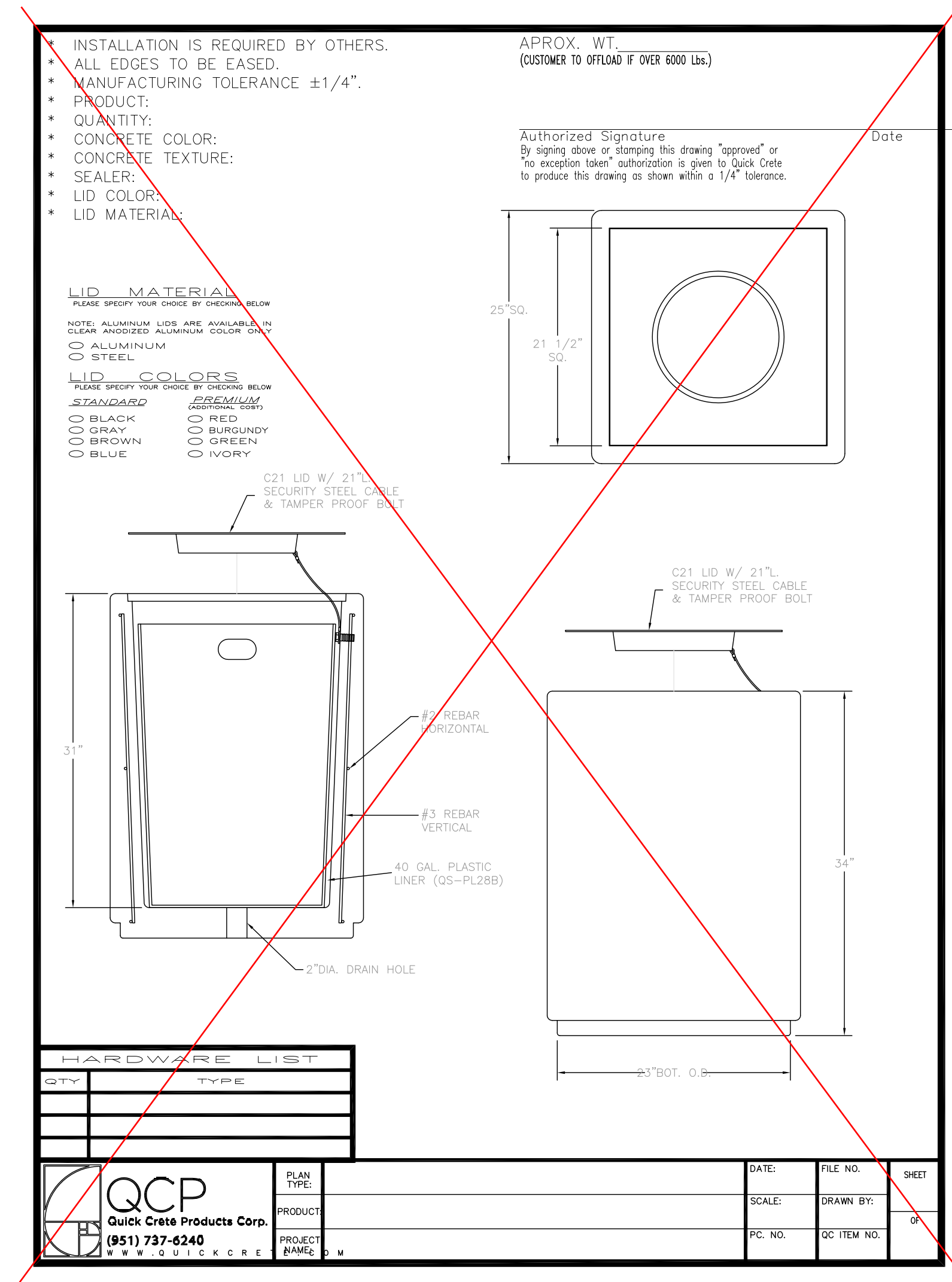
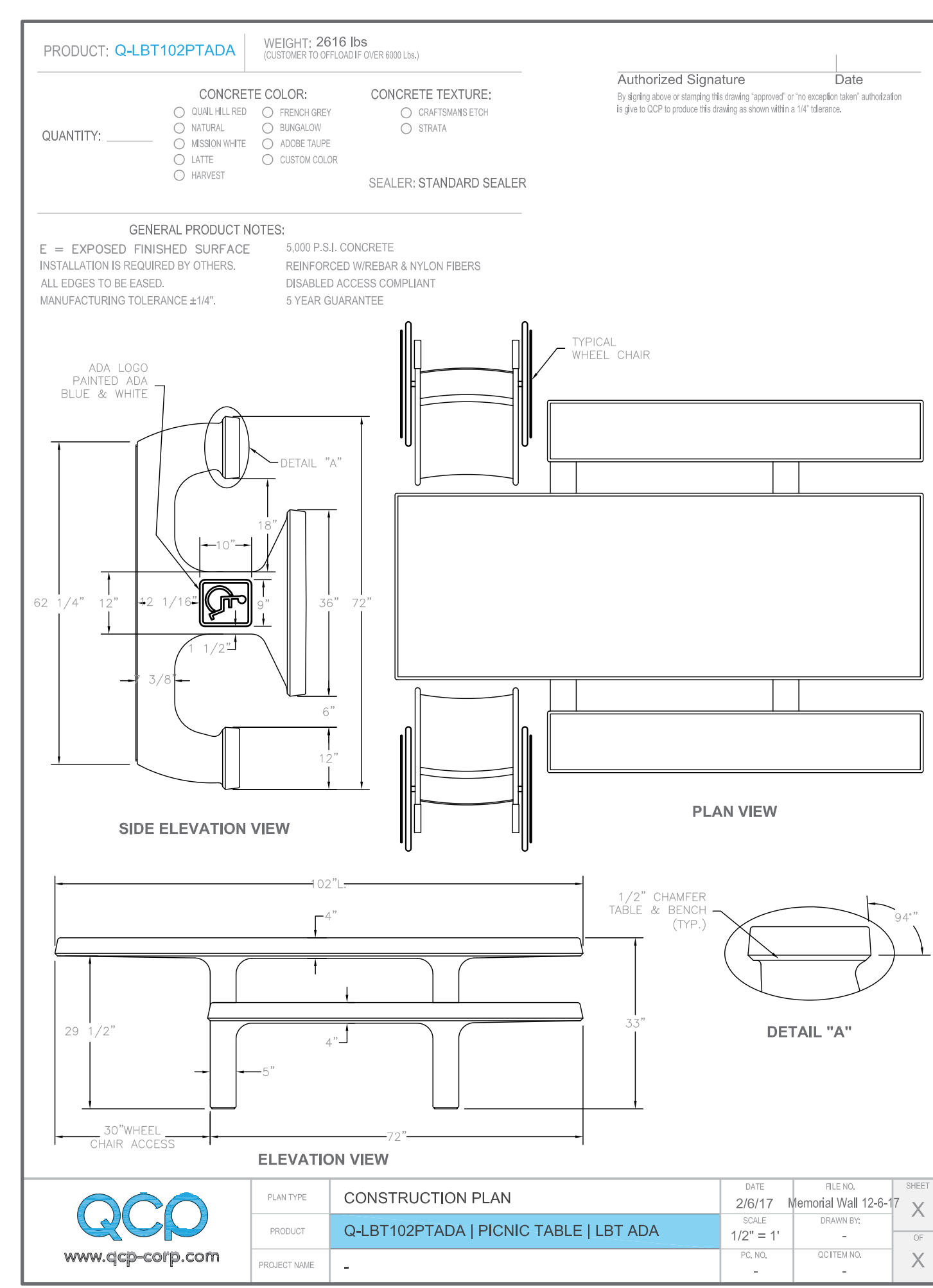
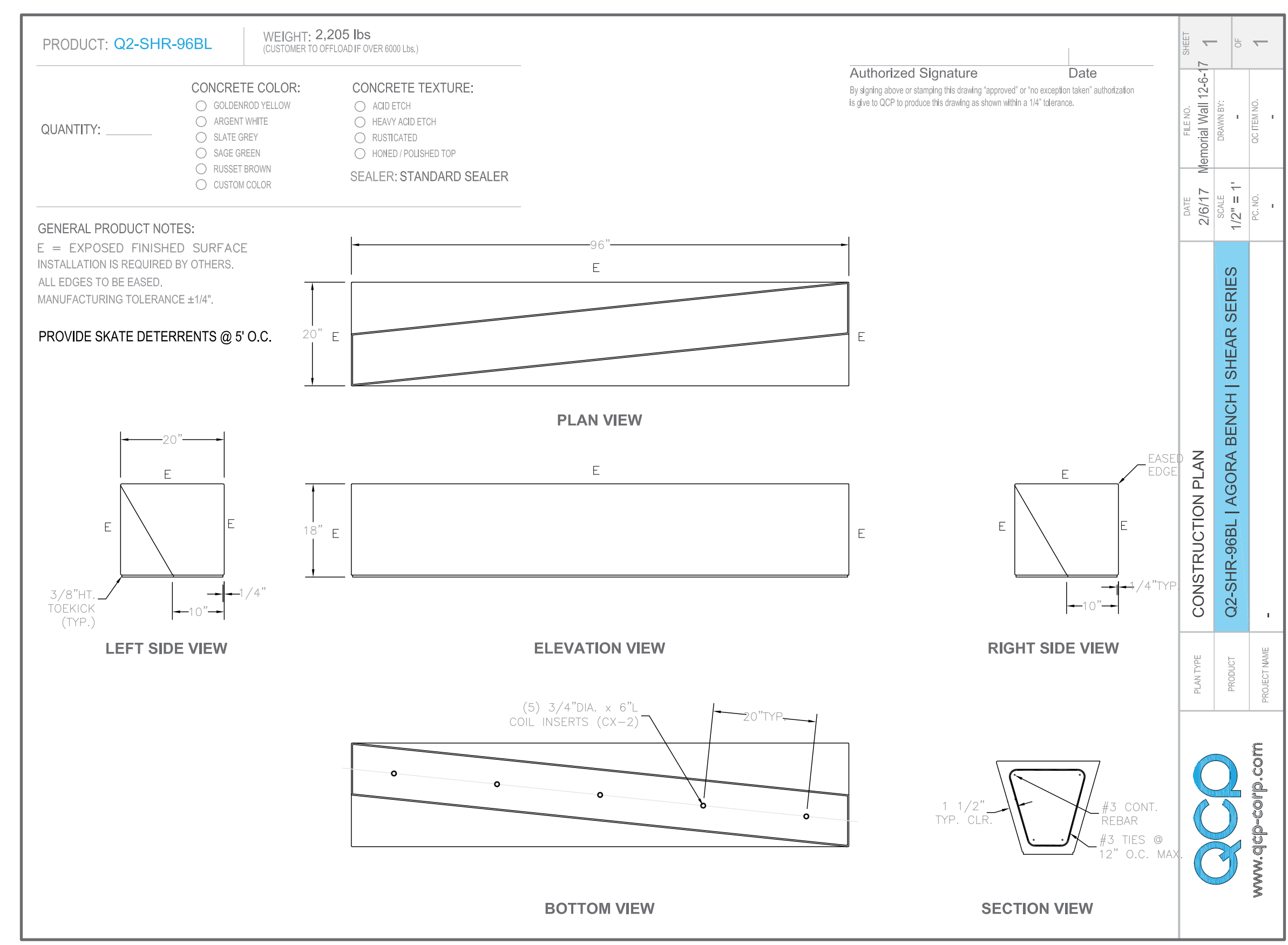
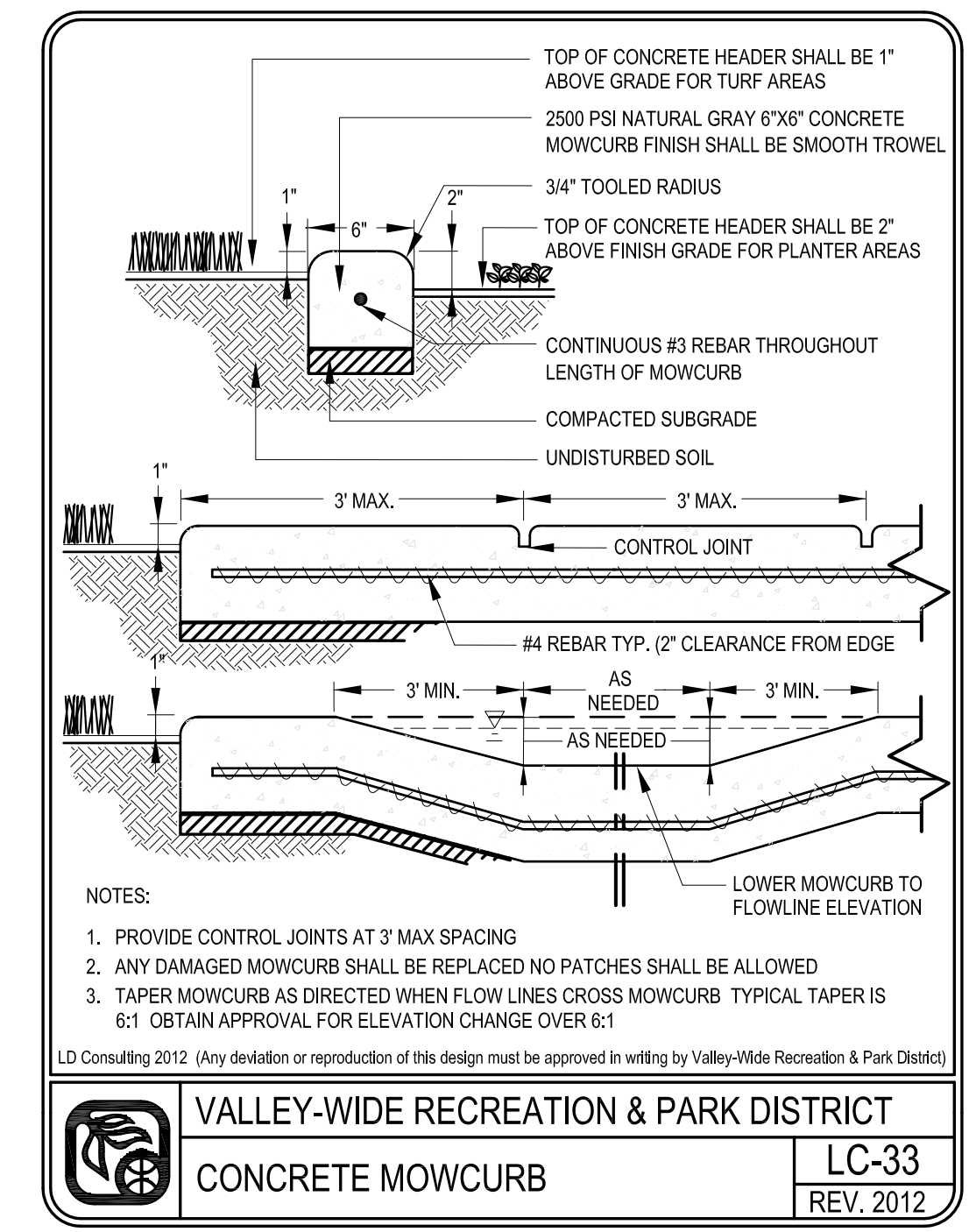
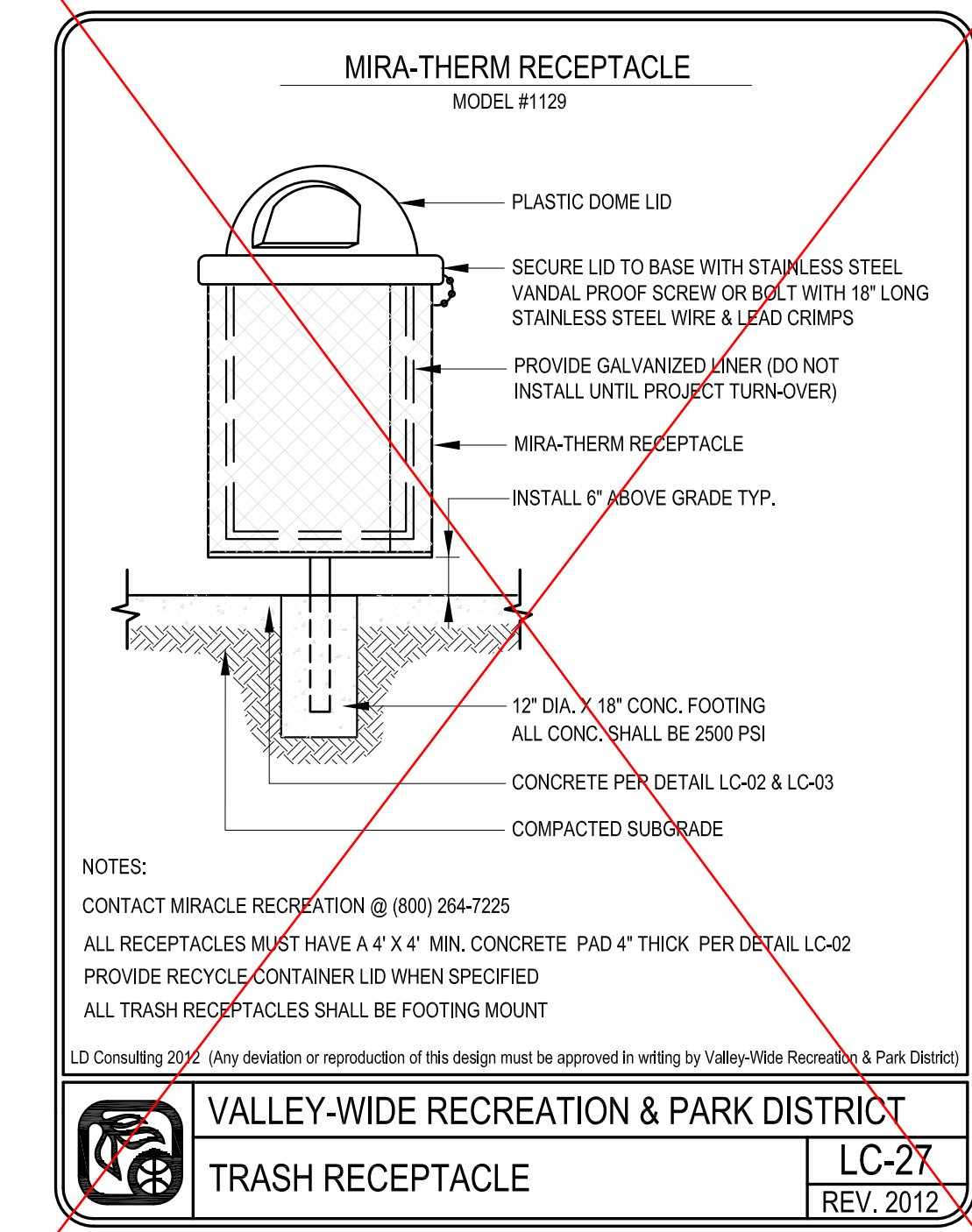
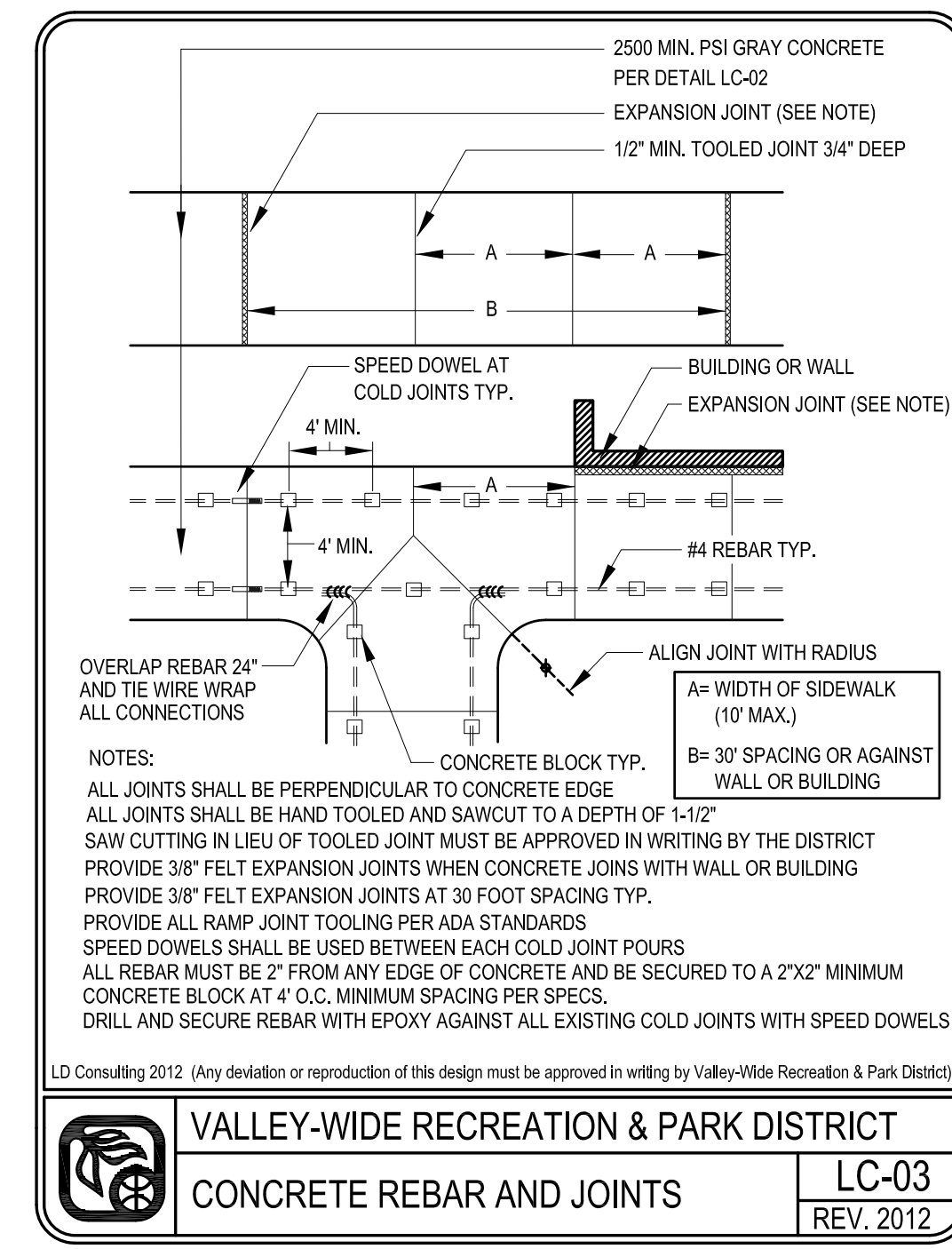
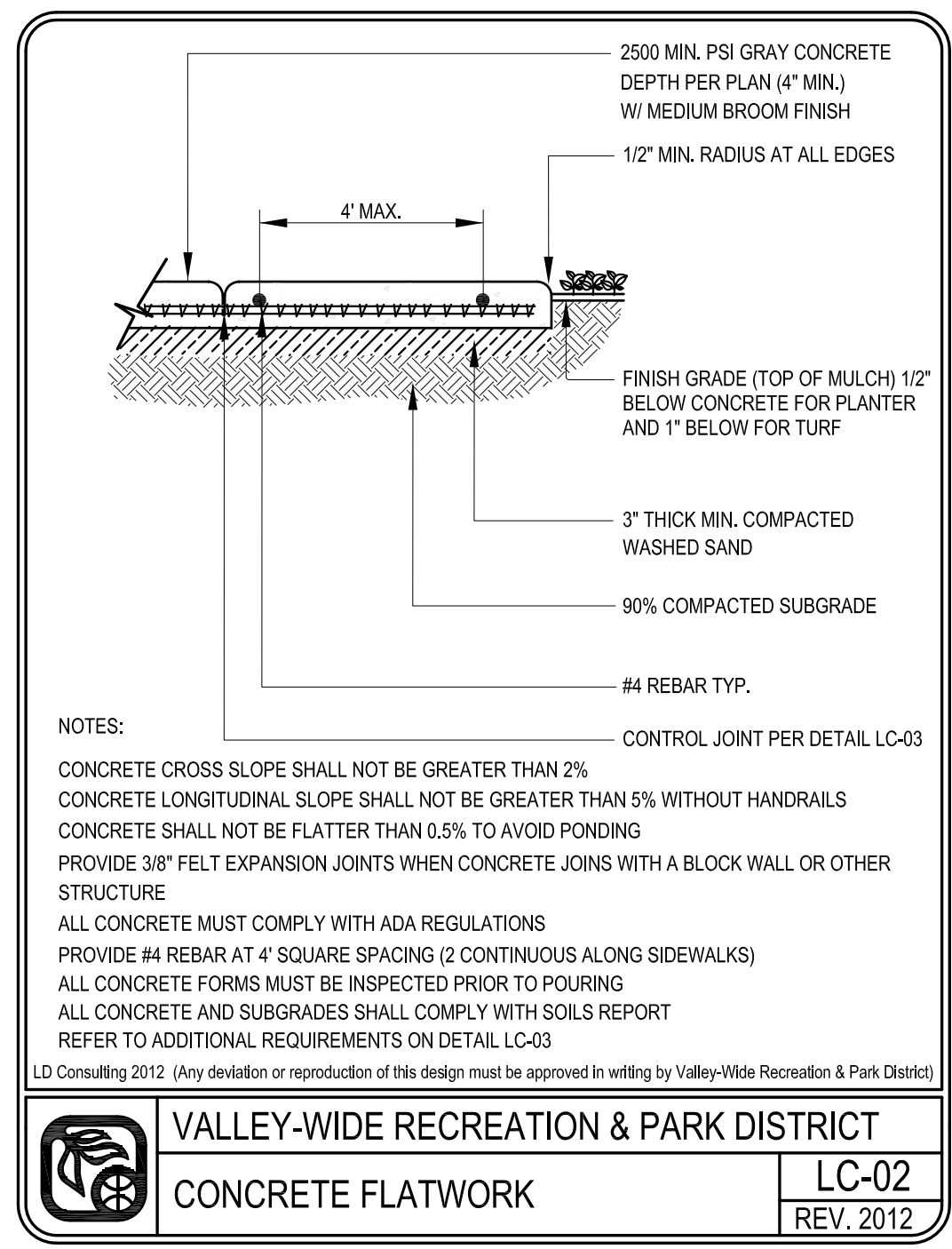

2-26-18

Underground Service Alert
Call: TOLL FREE
1-800-227-2600
TWO WORKING DAYS BEFORE YOU DIG

The private engineer signing these plans is responsible for assuring the accuracy and acceptability of the design hereon. In the event of discrepancies arising after city approval or during construction, the private engineer shall be responsible for determining an acceptable solution and revising the plans for approval by the City.

DATE	BY	MARK	REVISIONS	APPR.	DATE
DESIGNED BY	JP	DRAWN BY	JP	CHECKED BY	RA

CITY OF HEMET DATE _____

R.C.E. NO. _____ EXP. DATE _____

APPROVED BY _____ DATE _____

RCE _____

R.C.E. NO. _____ EXP. DATE _____

VALLEY WIDE RECREATION & PARK DISTRICT
901 W. Esplanade Ave.
P.O. Box 907
San Jacinto, CA 92581
(951) 654-1505
(951) 654-5279 FAX

SIGNATURE: _____ DATE _____
DEAN WETTER

IN THE CITY OF HEMET
CONSTRUCTION DETAILS
**DIAMOND VALLEY LAKE
MEMORIAL WALL**
1801 MARINA DR., HEMET, CA 92545

FOR VALLEY-WIDE W.O. 0000

SHEET NO. **D-1**
OF 7 SHTS.
FILE NO. _____

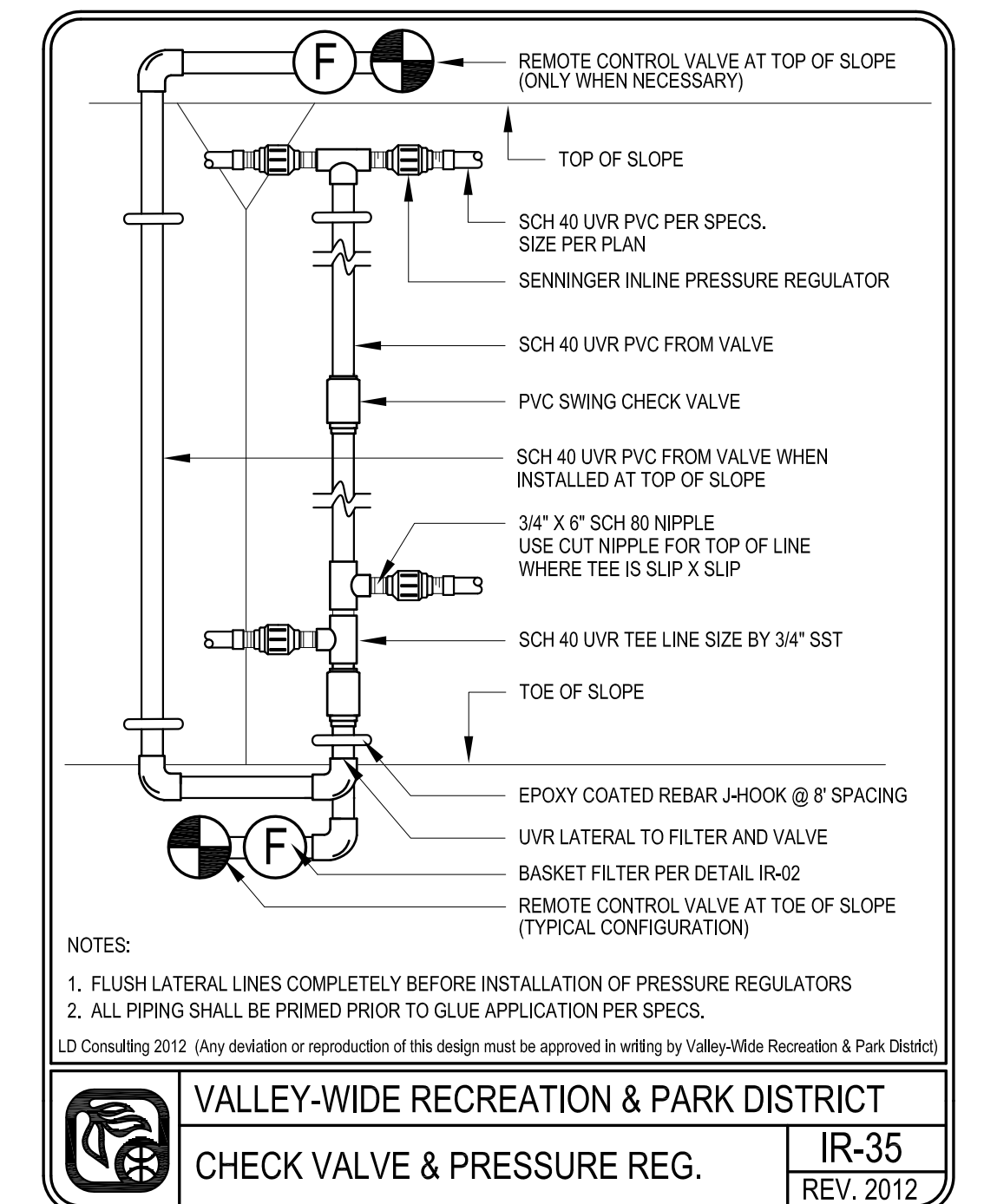
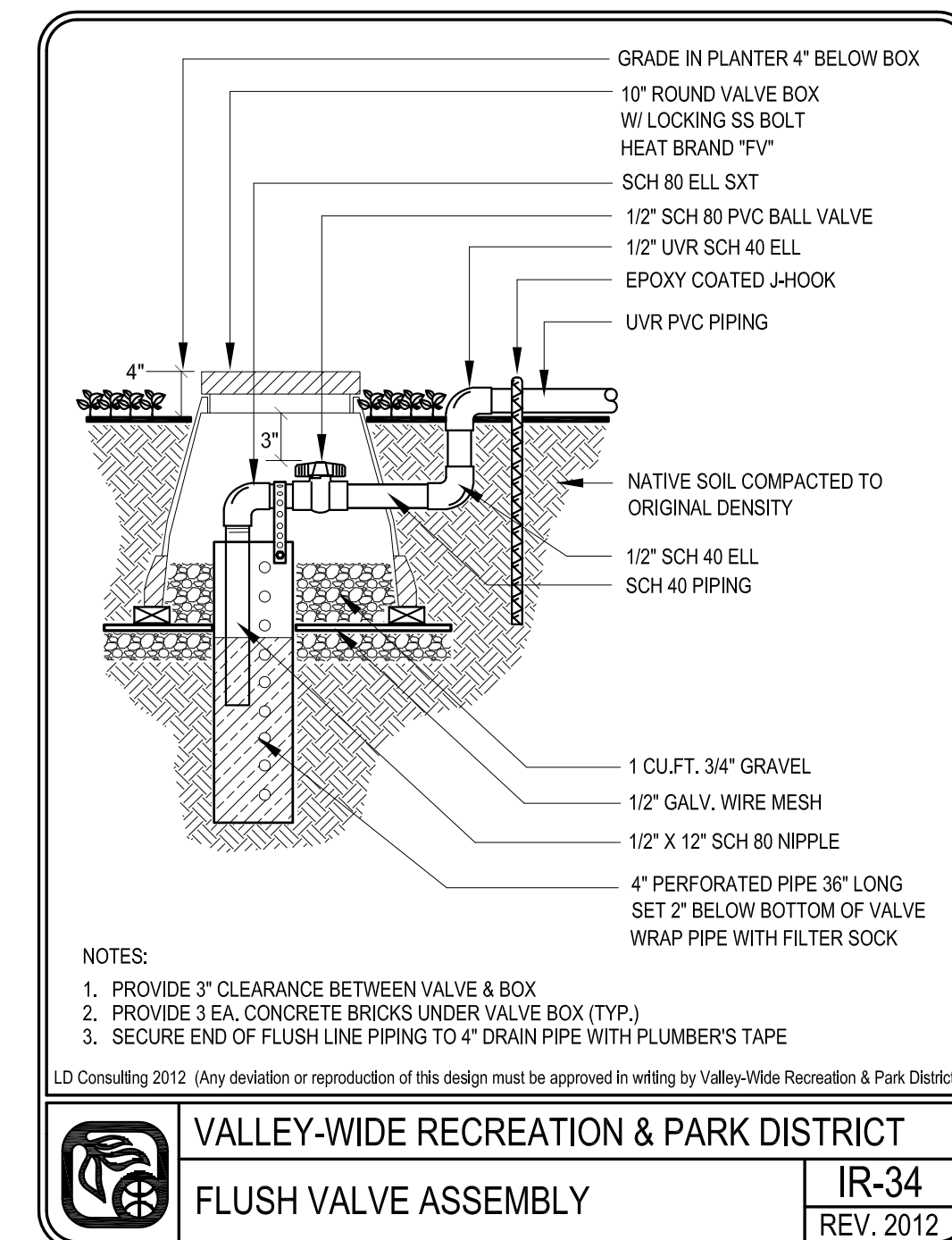
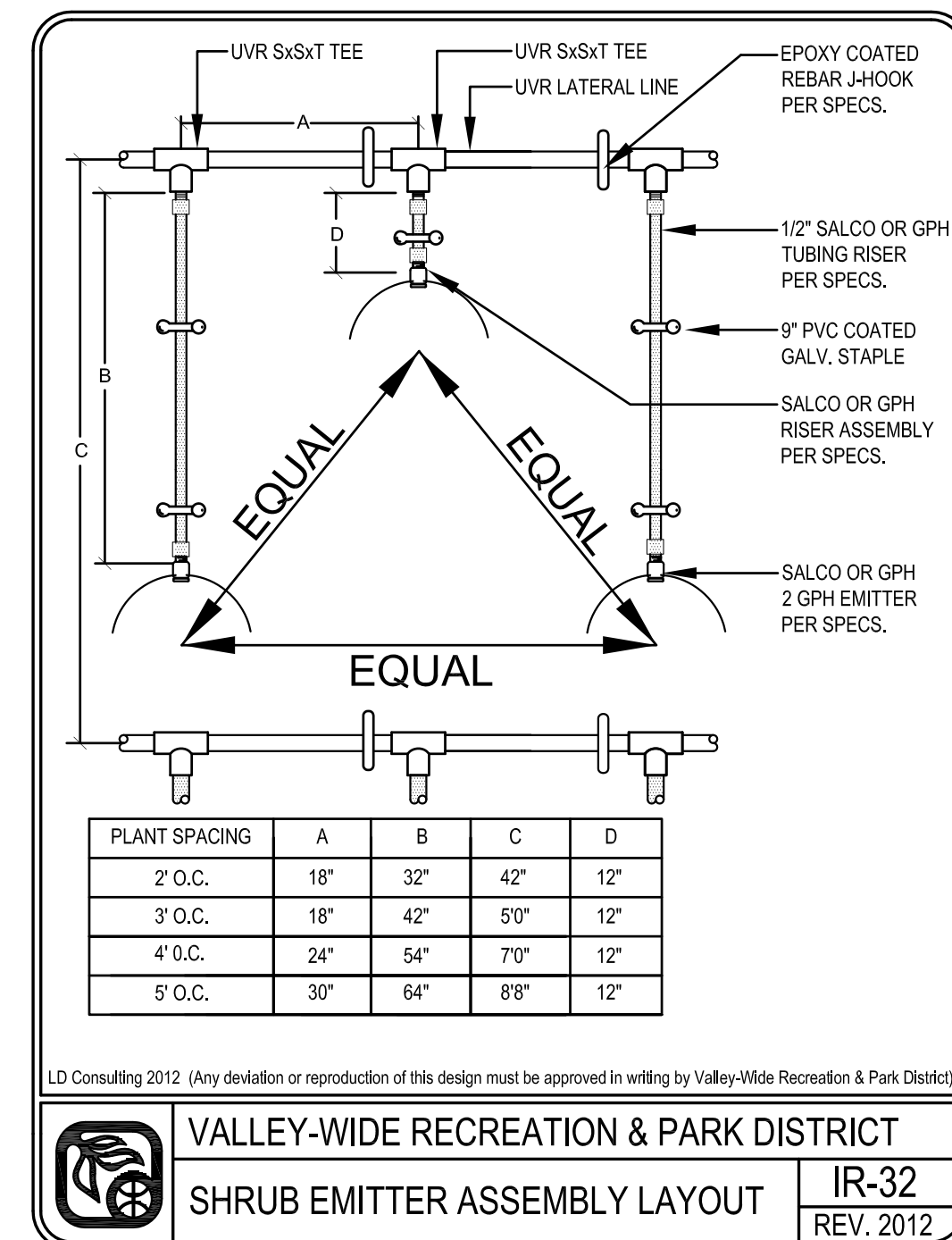
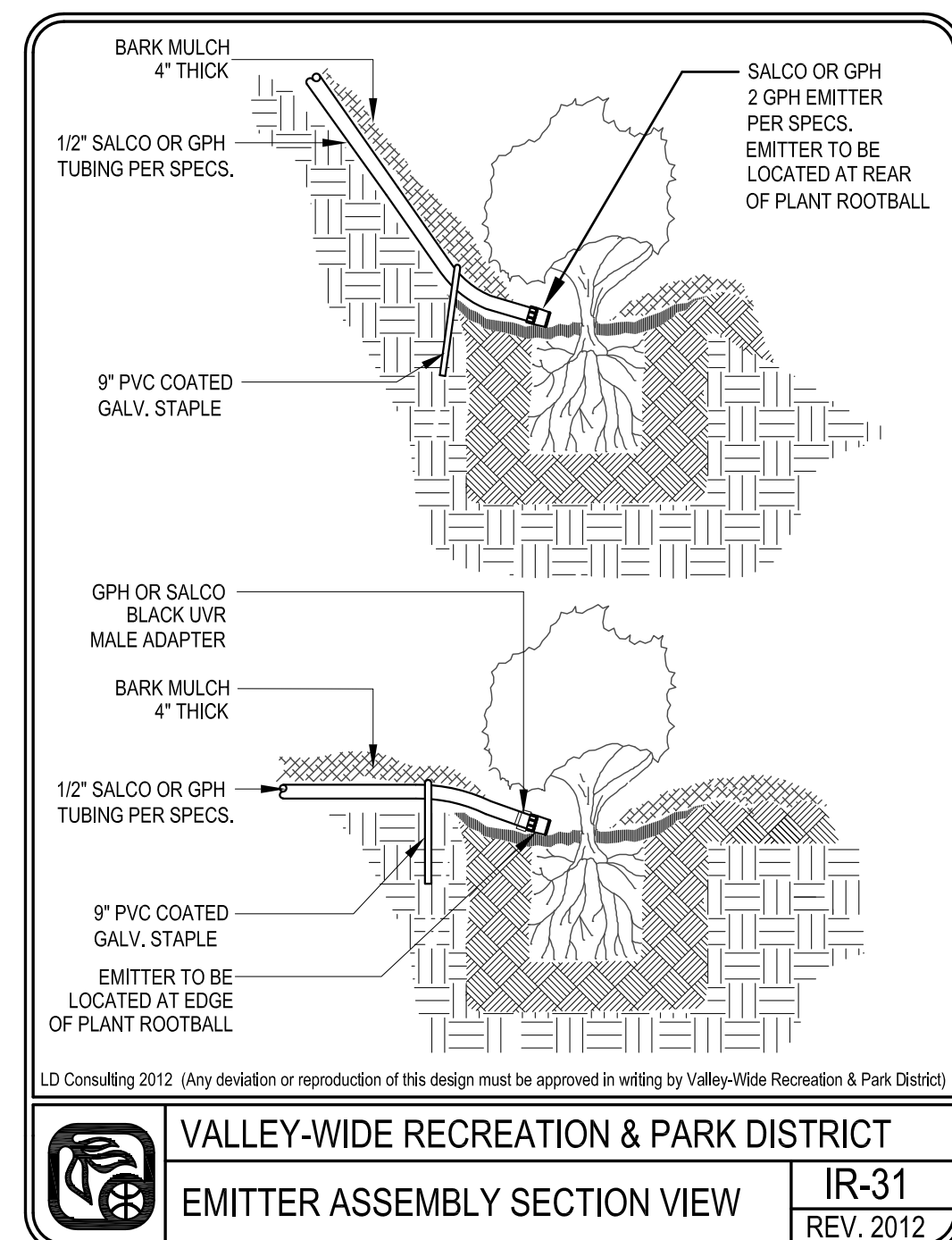
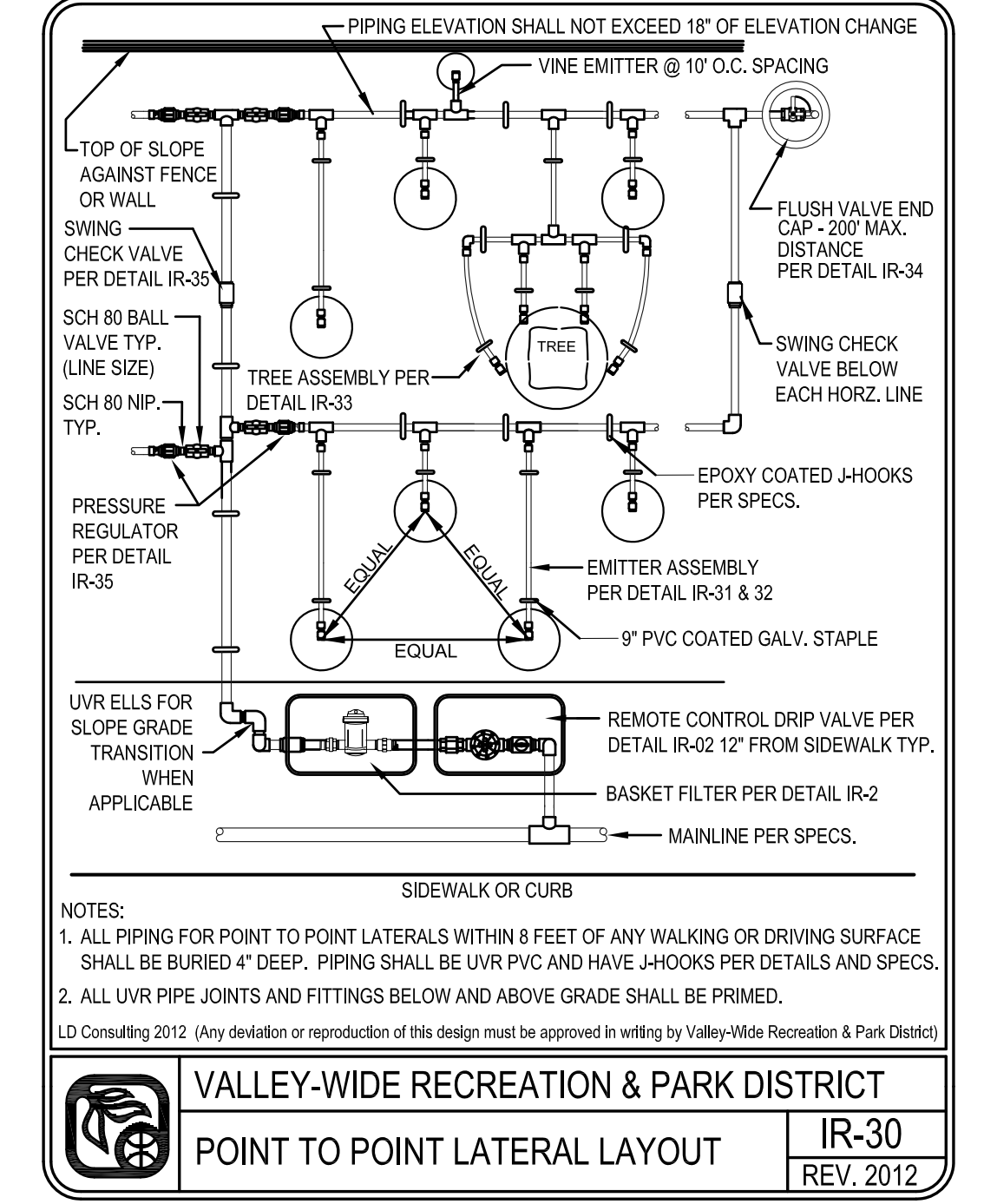
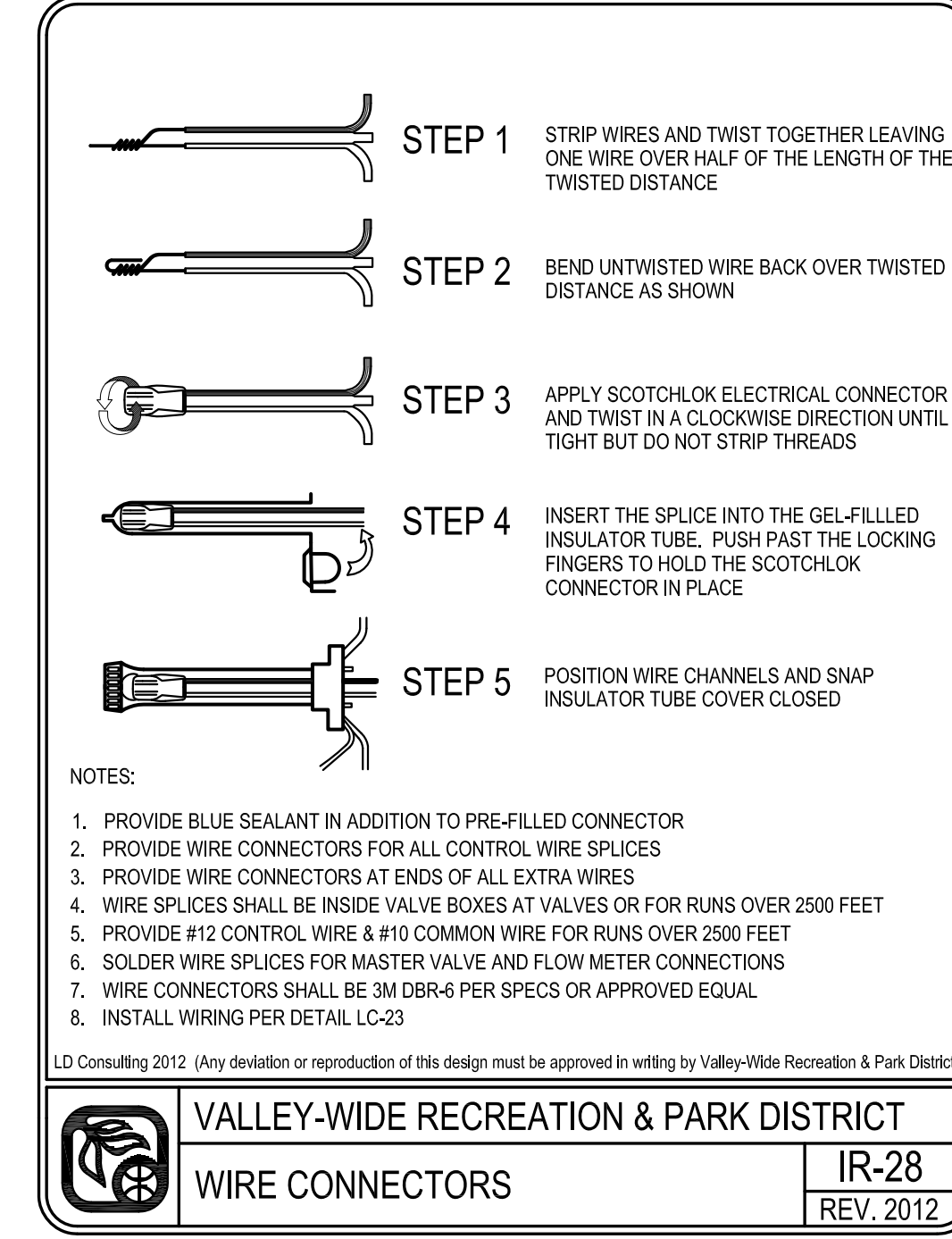
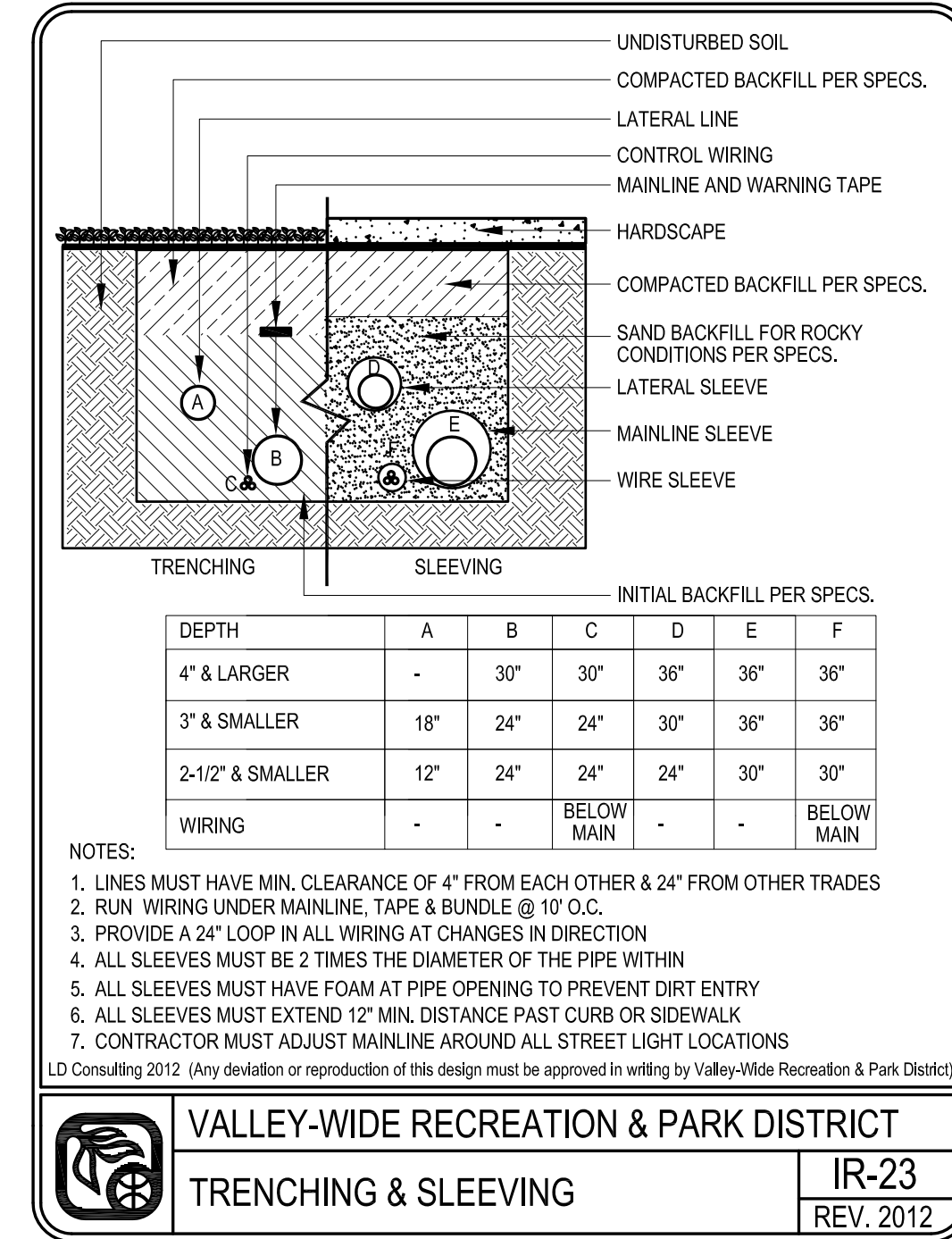
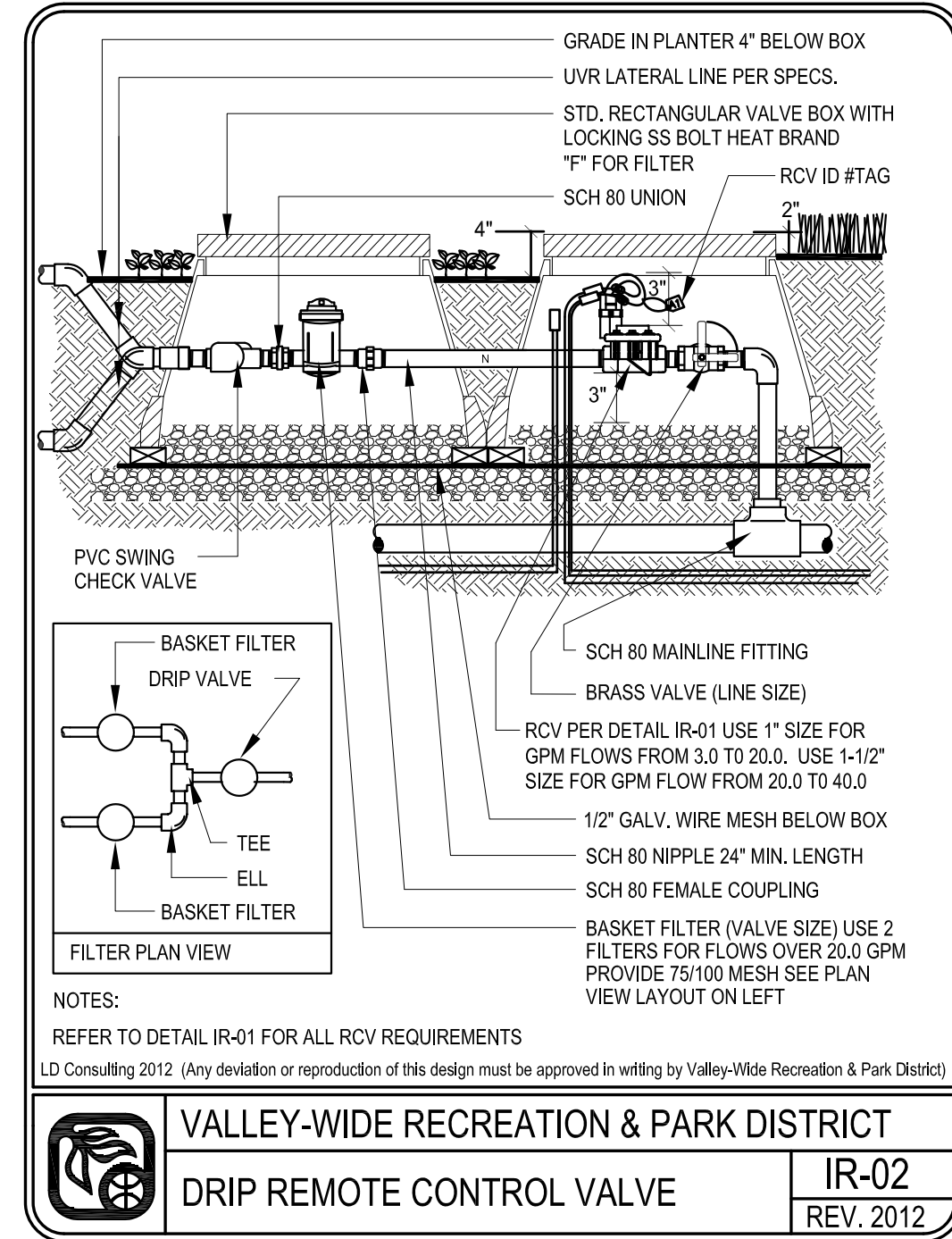

Underground Service Alert
Call: TOLL FREE
1-800-227-2600
TWO WORKING DAYS BEFORE YOU DIG

DATE BY MARK
ENGINEER REVISIONS CITY

DESIGNED BY JP DRAWN BY JP CHECKED BY RA

DATE	BY	MARK	REVISIONS	CITY

APPR.	DATE	CITY

CITY OF HEMET DATE _____

R.C.E. NO. _____ EXP. DATE _____

APPROVED BY DATE _____

RCE _____

R.C.E. NO. _____ EXP. DATE _____

VALLEY WIDE RECREATION & PARK DISTRICT
901 W. Esplanade Ave.
P.O. Box 907
San Jacinto, CA 92581
(951) 654-1505
(951) 654-5279 FAX

SIGNATURE: _____ DATE _____

DEAN WETTER

IN THE CITY OF HEMET
IRRIGATION DETAILS
**DIAMOND VALLEY LAKE
MEMORIAL WALL**
1801 MARINA DR., HEMET, CA 92545

FOR VALLEY-WIDE W.O. 0000

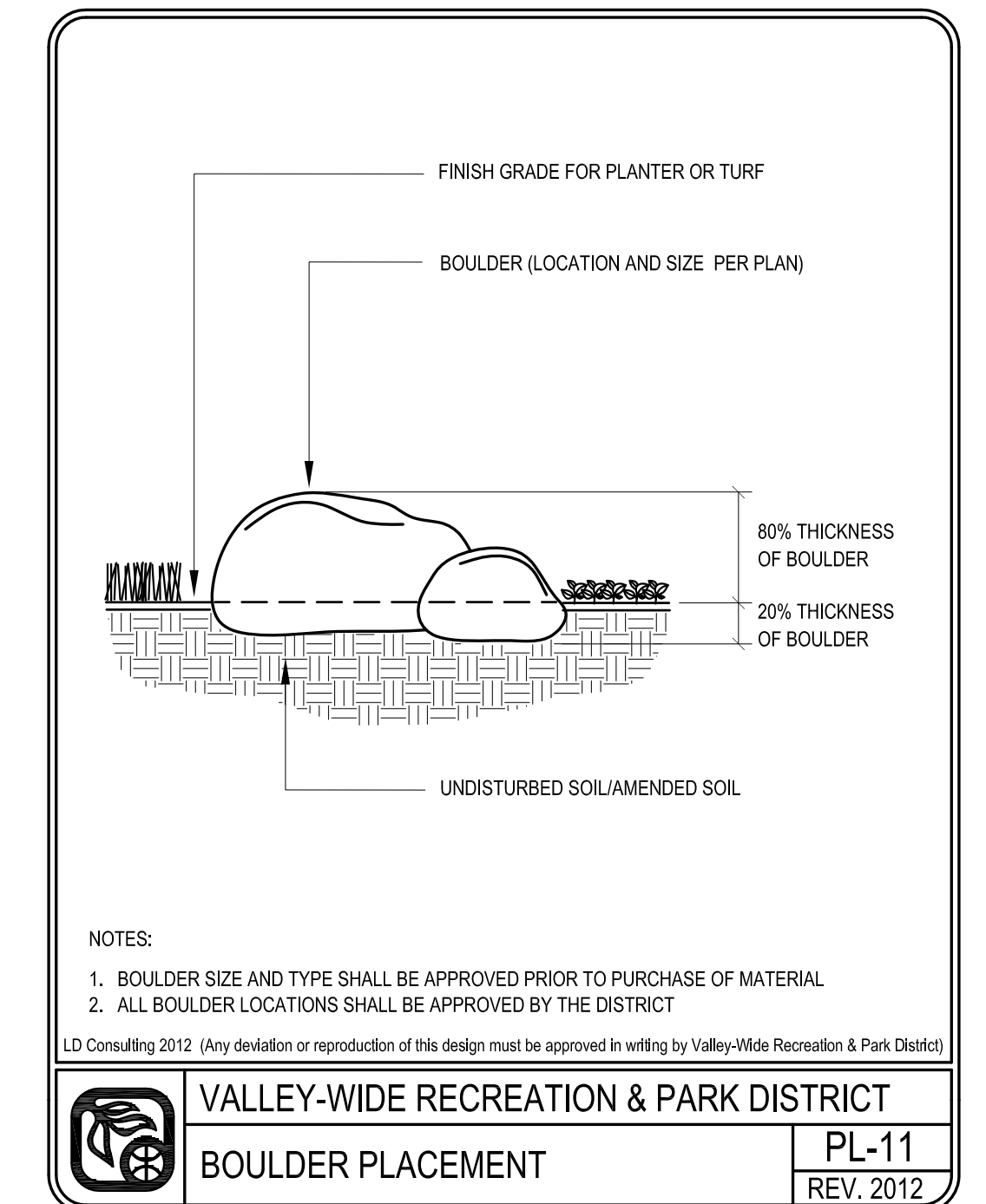
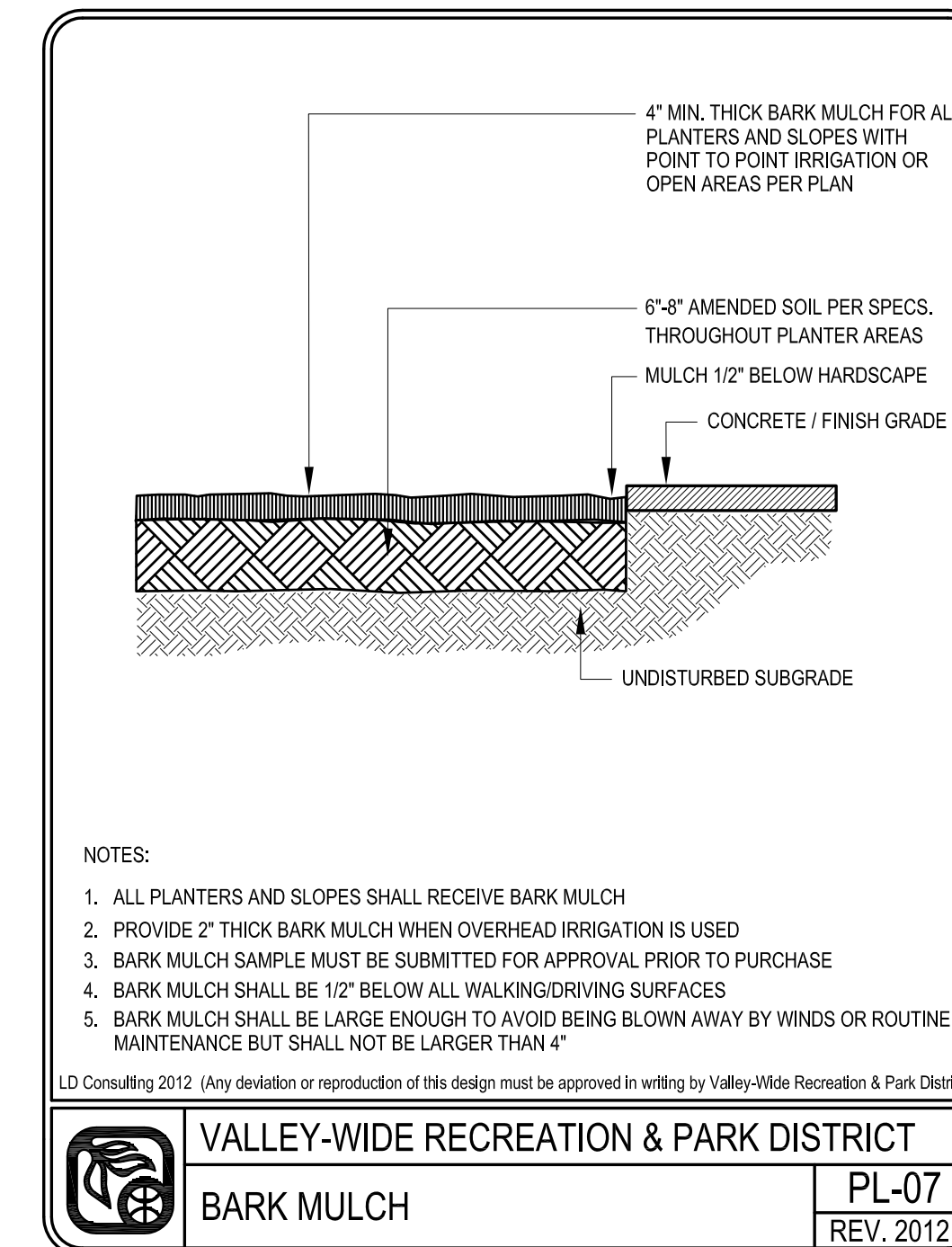
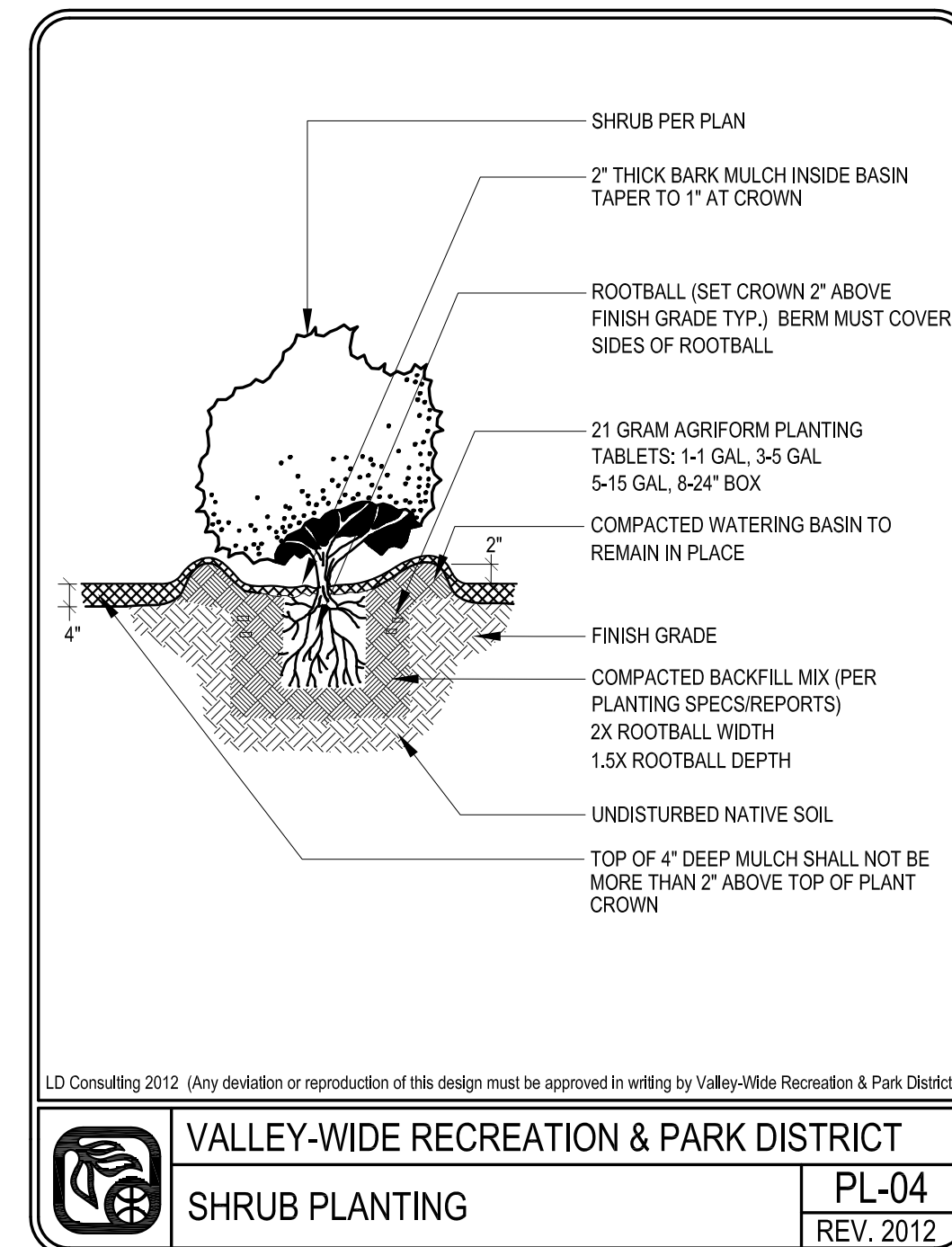
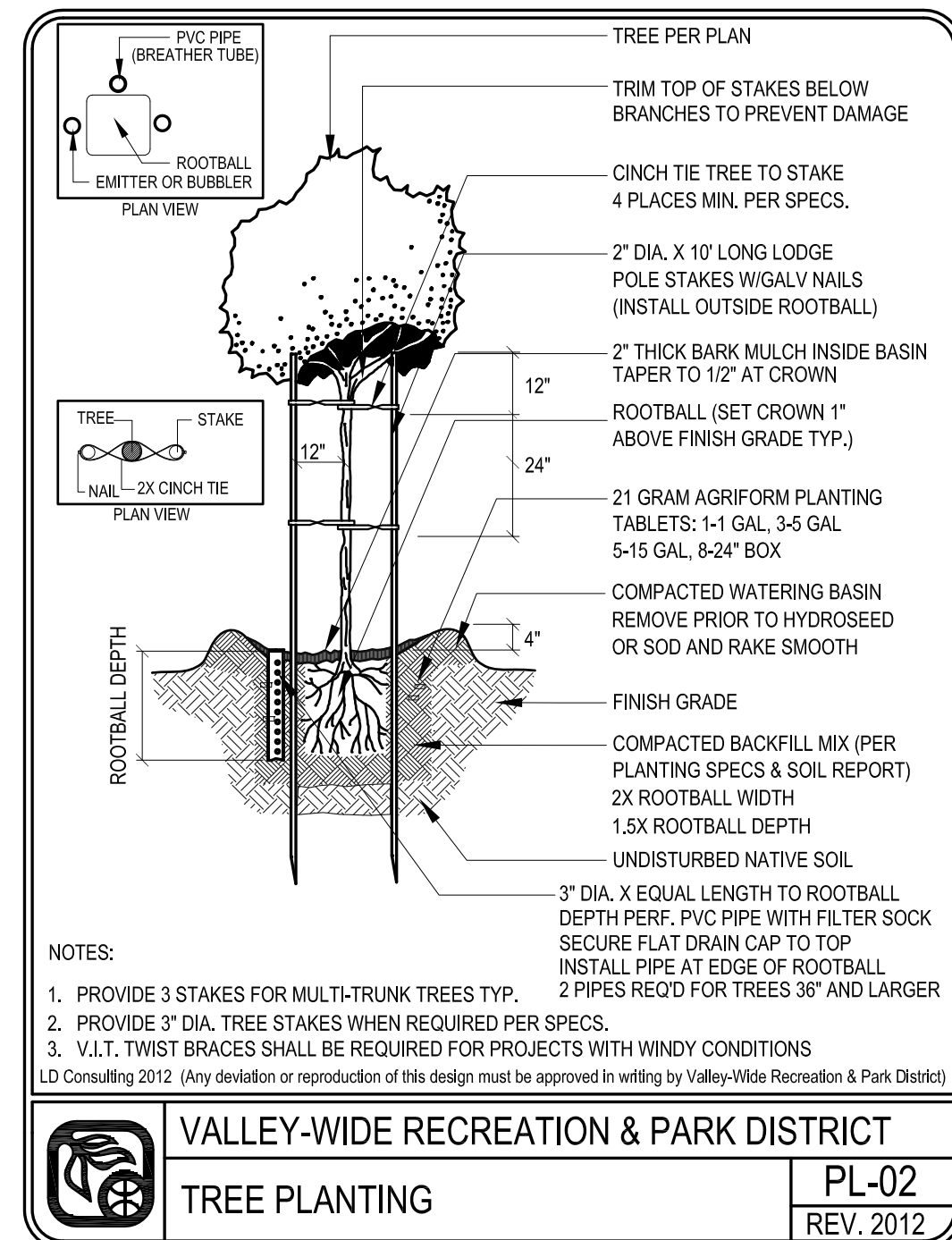

2-26-18

CALL BEFORE YOU DIG
Underground Service Alert
Call: TOLL FREE
1-800-227-2600
TWO WORKING DAYS BEFORE YOU DIG

The private engineer signing these plans is responsible for assuring the accuracy and acceptability of the design hereon. In the event of discrepancies arising after city approval or during construction, the private engineer shall be responsible for determining an acceptable solution and revising the plans for approval by the City.

DATE	BY	MARK	REVISIONS	APPR.	DATE

DESIGNED BY JP DRAWN BY JP CHECKED BY RA

CITY OF HEMET DATE _____

R.C.E. NO. _____ EXP. DATE _____

APPROVED BY DATE _____

RCE _____

R.C.E. NO. _____ EXP. DATE _____

VALLEY WIDE RECREATION & PARK DISTRICT
901 W. Esplanade Ave.
P.O. Box 907
San Jacinto, CA 92581
(951) 654-1505
(951) 654-5279 FAX

SIGNATURE: _____

DEAN WETTER DATE _____

IN THE CITY OF HEMET
PLANTING DETAILS
**DIAMOND VALLEY LAKE
MEMORIAL WALL**
1801 MARINA DR., HEMET, CA 92545

FOR VALLEY-WIDE W.O. 0000

SHEET NO. **D-3**
OF 7 SHTS.
FILE NO.

PRELIMINARY PICKLEBALL COURT GRADING PLAN

GRADING PLAN IS PRELIMINARY FOR BIDDING PURPOSES ONLY.

CONTRACTOR SHALL VERIFY ALL ELEVATIONS AND MAKE ADJUSTMENTS AS NECESSARY FOR COURTS TO HAVE A MINIMUM SLOPE OF 1% AND PLANTERS AND OPEN SPACE AREAS WITHIN THE LIMITS OF GRADING TO HAVE A MINIMUM SLOPE OF 0.50%.

ALL EXISTING GRADES AND FLOW LINES MUST DAYLIGHT TO EXISTING LOW POINT IN COBBLE AND FLOW TO PARKING LOT GUTTER AS SHOWN ON PLANS. EXACT ELEVATIONS MAY VARY AND IS THE CONTRACTOR'S RESPONSIBILITY TO ENSURE POSITIVE FLOW PRIOR TO START OF WORK.

CONTRACTOR SHALL BE RESPONSIBLE FOR OBTAINING GRADING PERMITS IF REQUIRED BY THE CITY OF HEMET.

ALL FLAT WORK MUST BE COMPACTED AND TESTED TO OBTAIN 95% COMPACTION AT THE CONTRACTOR'S EXPENSE.

FUTURE BUILDING

FUTURE BUILDING PAD

PROPOSED NEW PICKLEBALL COURTS

(E) IRR. VALVE TYP.

GRADING LIMIT OF WORK

UNDER SIDEWALK DRAIN

EXIST. PICKLEBALL COURT

NEW SIDEWALK TO BE UNDER 4.8% SLOPE. ALIGN CONCRETE WITH EXISTING SLAB.

CATCH BASIN

UNDERSIDEWALK DRAIN

EXTEND CONC. GUTTER

EXISTING ADA ACCESSIBLE RAMPS AND PARKING STALLS.

EXISTING SIDEWALKS TO REMAIN IN PLACE.

EXISTING ADA ACCESSIBLE RAMPS AND PARKING STALLS.

HOLD HARMLESS & INDEMNIFICATION CLAUSE

CONTRACTOR AGREES TO ASSUME SOLE RESPONSIBILITY FOR JOB SITE CONDITIONS DURING THE COURSE OF CONSTRUCTION OF THIS PROJECT, INCLUDING SAFETY OF ALL PERSONS AND PROPERTY; THAT THIS REQUIREMENT SHALL APPLY CONTINUOUSLY AND NOT BE LIMITED TO NORMAL WORKING HOURS, AND THAT THE CONTRACTOR SHALL DEFEND, INDEMNIFY, AND HOLD THE OWNER/DEVELOPER, THE COUNTY OF LOCAL JURISDICTION AND THE LANDSCAPE DESIGNER HARMLESS FROM ANY AND ALL LIABILITY REAL OR ALLEGED, IN CONNECTION WITH THE PERFORMANCE OF WORK ON THIS PROJECT, EXCEPTING FOR LIABILITY ARISING FROM SOLE NEGLIGENCE OF THE OWNER/DEVELOPER, COUNTY OF LOCAL JURISDICTION AND THE LANDSCAPE DESIGNER.

Underground Service Alert
Call: TOLL FREE
1-800-227-2600
TWO WORKING DAYS BEFORE YOU DIG

The private engineer signing these plans is responsible for assuring the accuracy and acceptability of the design hereon. In the event of discrepancies arising after city approval or during construction, the private engineer shall be responsible for determining an acceptable solution and revising the plans for approval by the City.

DATE	BY	MARK	REVISIONS	APPR.	DATE
	ENGINEER				CITY
DESIGNED BY	JP	DRAWN BY	JP	CHECKED BY	RA

CITY OF HEMET

DATE _____

R.C.E. NO. _____ EXP. DATE _____

APPROVED BY _____ DATE _____

RCE _____

R.C.E. NO. _____ EXP. DATE _____

VALLEY WIDE RECREATION & PARK DISTRICT

901 W. Esplanade Ave.
P.O. Box 907
San Jacinto, CA 92581
(951) 654-1505
(951) 654-5279 FAX

SIGNATURE: _____

DEAN WETTER

DATE _____

IN THE CITY OF HEMET
PRELIMINARY GRADING PLAN FOR DIAMOND VALLEY LAKE PICKLEBALL COURTS
1801 MARINA DR., HEMET, CA 92545

FOR VALLEY-WIDE W.O. 0000

SHEET NO. **S1**
OF 7 SHTS.
FILE NO. _____

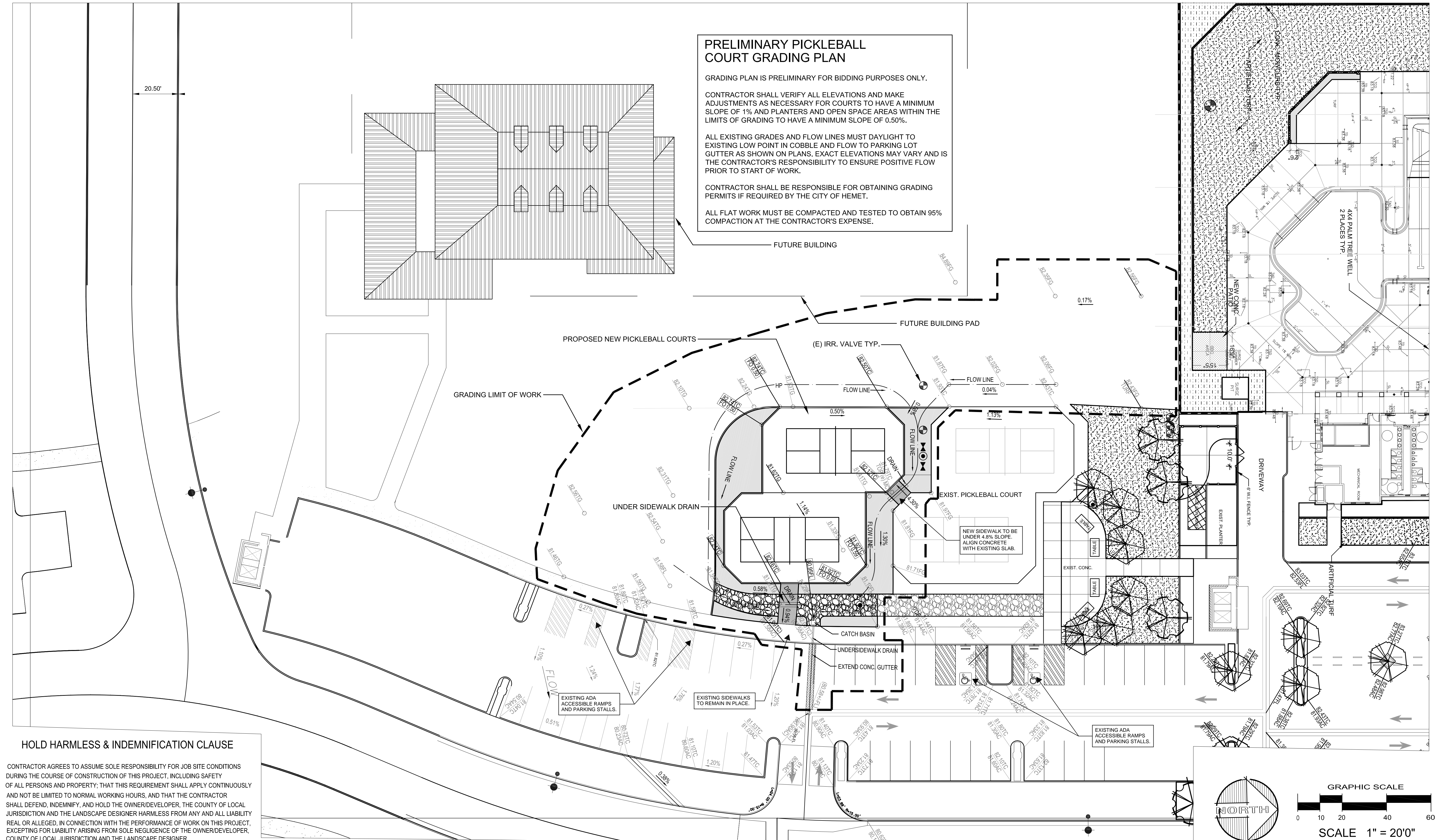
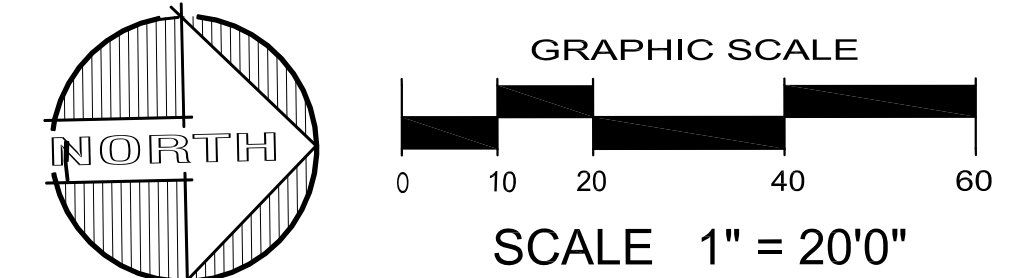

CONSTRUCTION LEGEND

SYB.	QTY.	DESCRIPTION	DETAIL # / NOTES
①	PER PLAN	3250 PSI CONCRETE 6" THICK OVER 3" CL II BASE WITH #4 BARS AT 36" SPACING. SCARIFY 12" DEEP PRIOR TO POURING.	LC-02 & LC-03
②	PER PLAN	4' HIGH CHAIN LINK FENCE TYP. WITH TOP AND BOTTOM RAIL POST TO BE INSTALLED WITHIN 3" OF CONCRETE EDGE TYP.	LC-10
③	2 EA	4' HIGH X 5' WIDE DOUBLE SWING CHAIN LINK GATE	LC-11
④	2 EA	COMMERCIAL PICKLEBALL POST. INSTALL PER MANUFACTURER'S SPECIFICATIONS. PROVIDE NET TO VWRPD.	- INSTALL PER MANUFACTURER
⑤	2 EA	PICKLEBALL COURT SURFACING AND STRIPING PER VWRPD SPECS. COLORS TO MATCH EXISTING COURTS.	LC-XX INSTALL PER MANUFACTURER
⑥	PER PLAN	4"-8" ARIZONA RIVER ROCK DRY RIVER BED	-
⑦	PER PLAN	6X6 CONCRETE MOWCURB WITH #3 REBAR	LC-6 & LC-33
⑧	PER PLAN	3250 PSI CONCRETE 4" THICK OVER 3" SAND BASE WITH #4 BARS AT 48" SPACING. SCARIFY 12" DEEP PRIOR TO POURING.	LC-02 & LC-03
⑨	1 EA	TRASH RECEPTACLE MIRACLE MODEL 1129	LC-27
⑩	1 EA	CATCH BASIN PER GRADING PLAN CATCH BASIN PER GRADING PLAN	
⑪	2 EA	UNDERSIDEWALK DRAIN PER GRADING PLAN	
⑫	PER PLAN	GRADED FLOW LINE PER GRADING PLAN	

CONSTRUCTION NOTES

- ALL WORK MUST CONFORM TO VALLEY-WIDE'S CURRENT LANDSCAPE STANDARDS.
- CONTRACTOR SHALL VERIFY ALL QUANTITIES ON PLAN WITH LEGEND.
- CONTRACTOR SHALL ADJUST ELEVATIONS AS NEEDED TO ENSURE 1%-1.5% CONCRETE SLOPE.
- CONTRACTOR SHALL FINISH GRADE ALL ADJACENT AREAS TO FLOW AWAY FROM CONCRETE AND TOWARDS FLOWLINES.
- ALL MOWCURBS WITHIN FLOWLINES SHALL BE LOWERED PER VWRPD DETAIL AS REQUIRED TO NOT RESTRICT FLOW.
- CONTRACTOR SHALL GROUT IN PLACE ARIZONA COBBLE AT UNDER SIDEWALK DRAIN PIPES.
- ALL COLD JOINTS SHALL HAVE DOWELS AT 24" SPACING TYP.
- CONTRACTOR SHALL CALL FOR THE FOLLOWING INSPECTIONS:
 SITE GRADING, INCLUDING NEW FLOW LINES
 CONCRETE FORMS, INCLUDING REBAR
 POST FOOTINGS
 FINAL FINISH OF CONCRETE
 VALLEY-WIDE INSPECTION DEPT.
 CALL (951) 660-4700
 48 HOUR NOTICE FOR INSPECTIONS
 7 DAY NOTICE FOR FINAL WALK.

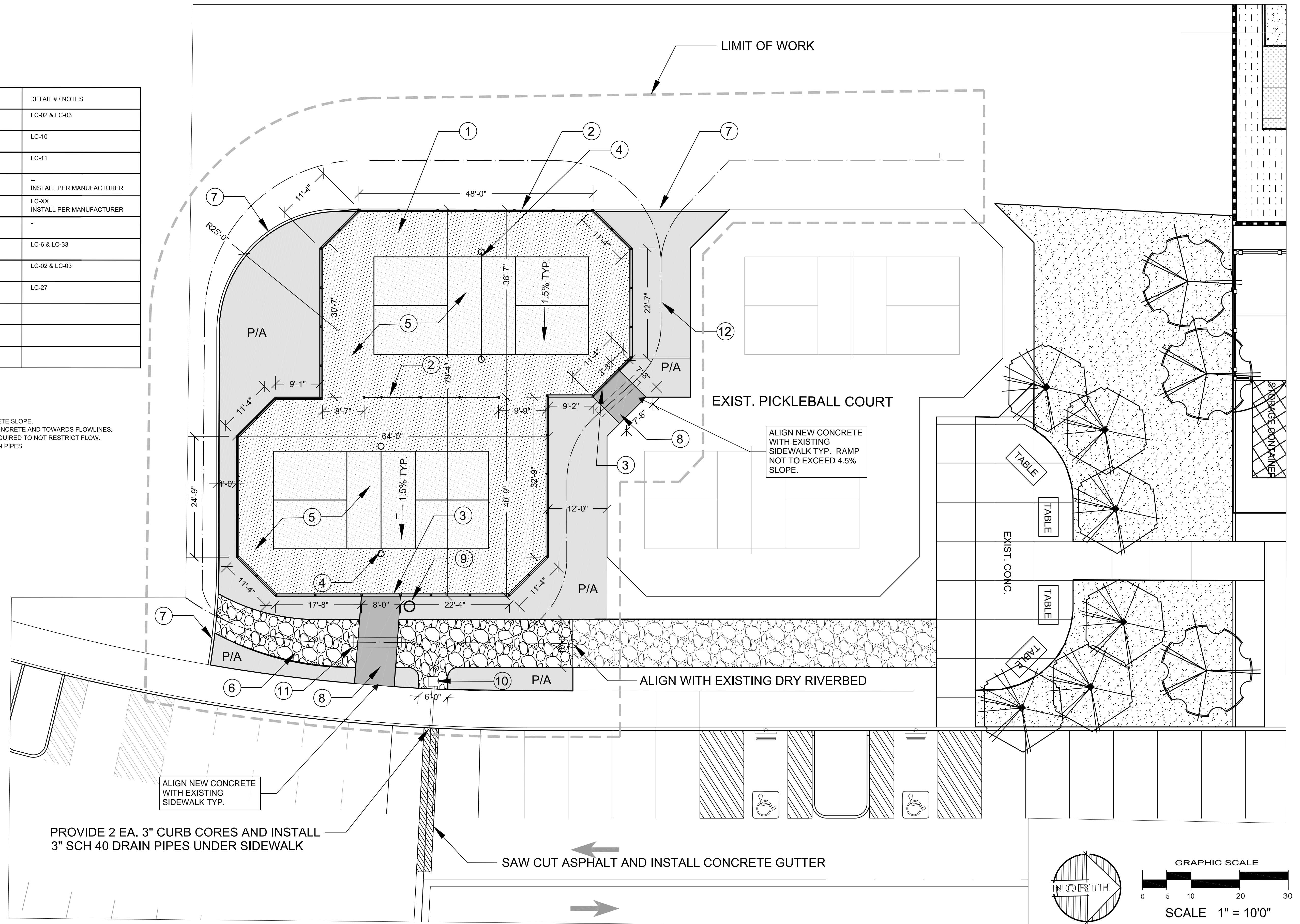

HOLD HARMLESS & INDEMNIFICATION CLAUSE

CONTRACTOR AGREES TO ASSUME SOLE RESPONSIBILITY FOR JOB SITE CONDITIONS DURING THE COURSE OF CONSTRUCTION OF THIS PROJECT, INCLUDING SAFETY OF ALL PERSONS AND PROPERTY; THAT THIS REQUIREMENT SHALL APPLY CONTINUOUSLY AND NOT BE LIMITED TO NORMAL WORKING HOURS, AND THAT THE CONTRACTOR SHALL DEFEND, INDEMNIFY, AND HOLD THE OWNER/DEVELOPER, THE COUNTY OF LOCAL JURISDICTION AND THE LANDSCAPE DESIGNER HARMLESS FROM ANY AND ALL LIABILITY REAL OR ALLEGED, IN CONNECTION WITH THE PERFORMANCE OF WORK ON THIS PROJECT, EXCEPTING FOR LIABILITY ARISING FROM SOLE NEGLIGENCE OF THE OWNER/DEVELOPER, COUNTY OF LOCAL JURISDICTION AND THE LANDSCAPE DESIGNER.

PROVIDE 2 EA. 3" CURB CORES AND INSTALL 3" SCH 40 DRAIN PIPES UNDER SIDEWALK

SAW CUT ASPHALT AND INSTALL CONCRETE GUTTER

Underground Service Alert
 Call: TOLL FREE
 1-800-227-2600
 TWO WORKING DAYS BEFORE YOU DIG

The private engineer signing these plans is responsible for assuring the accuracy and acceptability of the design hereon. In the event of discrepancies arising after city approval or during construction, the private engineer shall be responsible for determining an acceptable solution and revising the plans for approval by the City.

DATE	BY	MARK	REVISIONS	APPR.	DATE
DESIGNED BY	JP	DRAWN BY	JP	CHECKED BY	RA

CITY OF HEMET DATE _____
 R.C.E. NO. _____ EXP. DATE _____
 APPROVED BY DATE _____
 R.C.E. NO. _____ EXP. DATE _____

VALLEY WIDE RECREATION & PARK DISTRICT
 901 W. Esplanade Ave.
 P.O. Box 907
 San Jacinto, CA 92581
 (951) 654-1505
 (951) 654-5279 FAX

SIGNATURE: _____
 DEAN WETTER DATE _____

IN THE CITY OF HEMET
 LANDSCAPE CONSTRUCTION PLAN
DIAMOND VALLEY LAKE PICKLEBALL COURTS
 1801 MARINA DR., HEMET, CA 92545
 FOR VALLEY-WIDE W.O. 0000

SHEET NO. **LC-01**
 OF 7 SHTS.
 FILE NO.

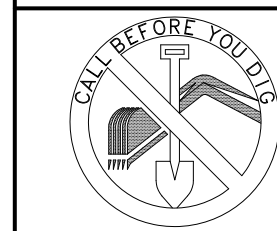
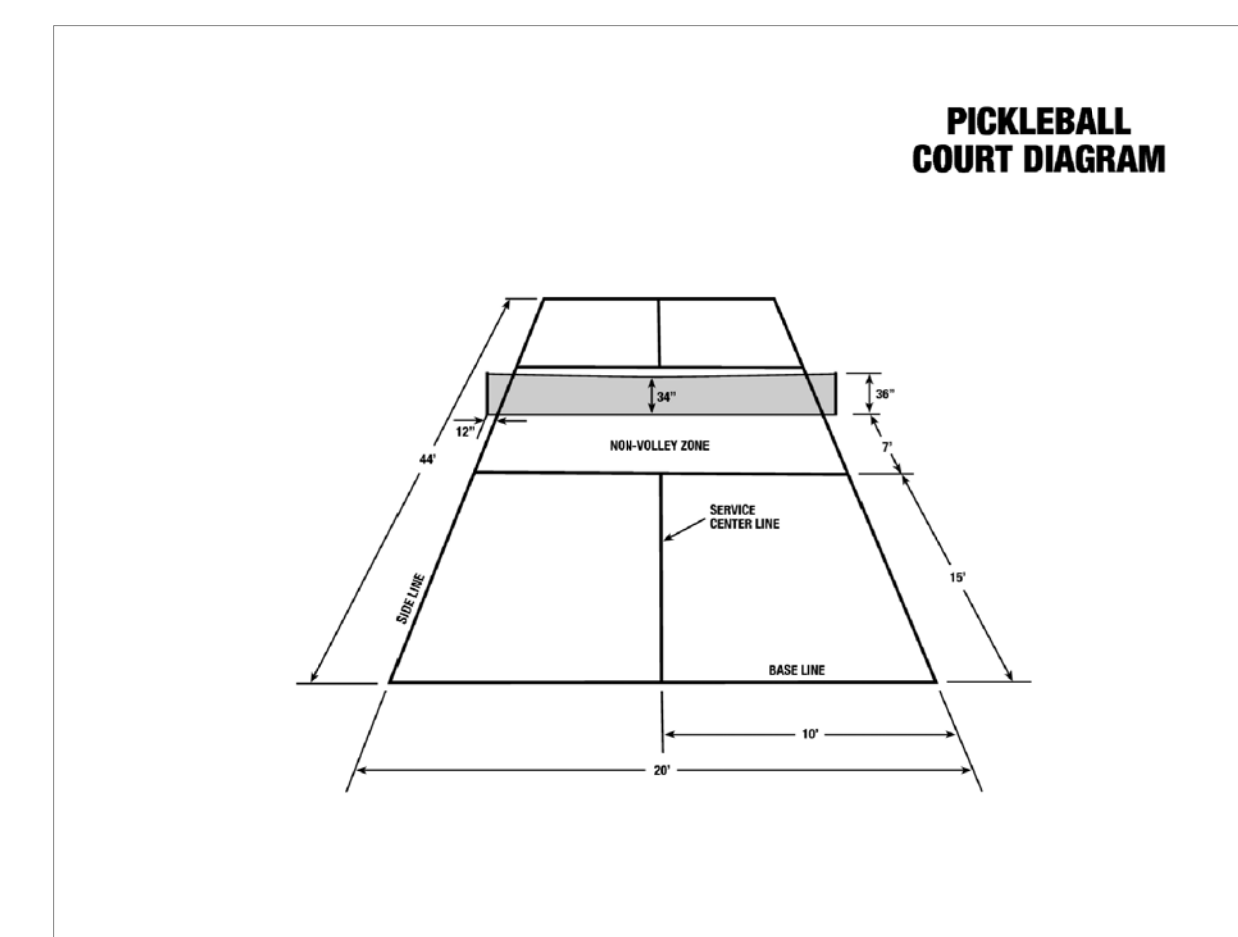
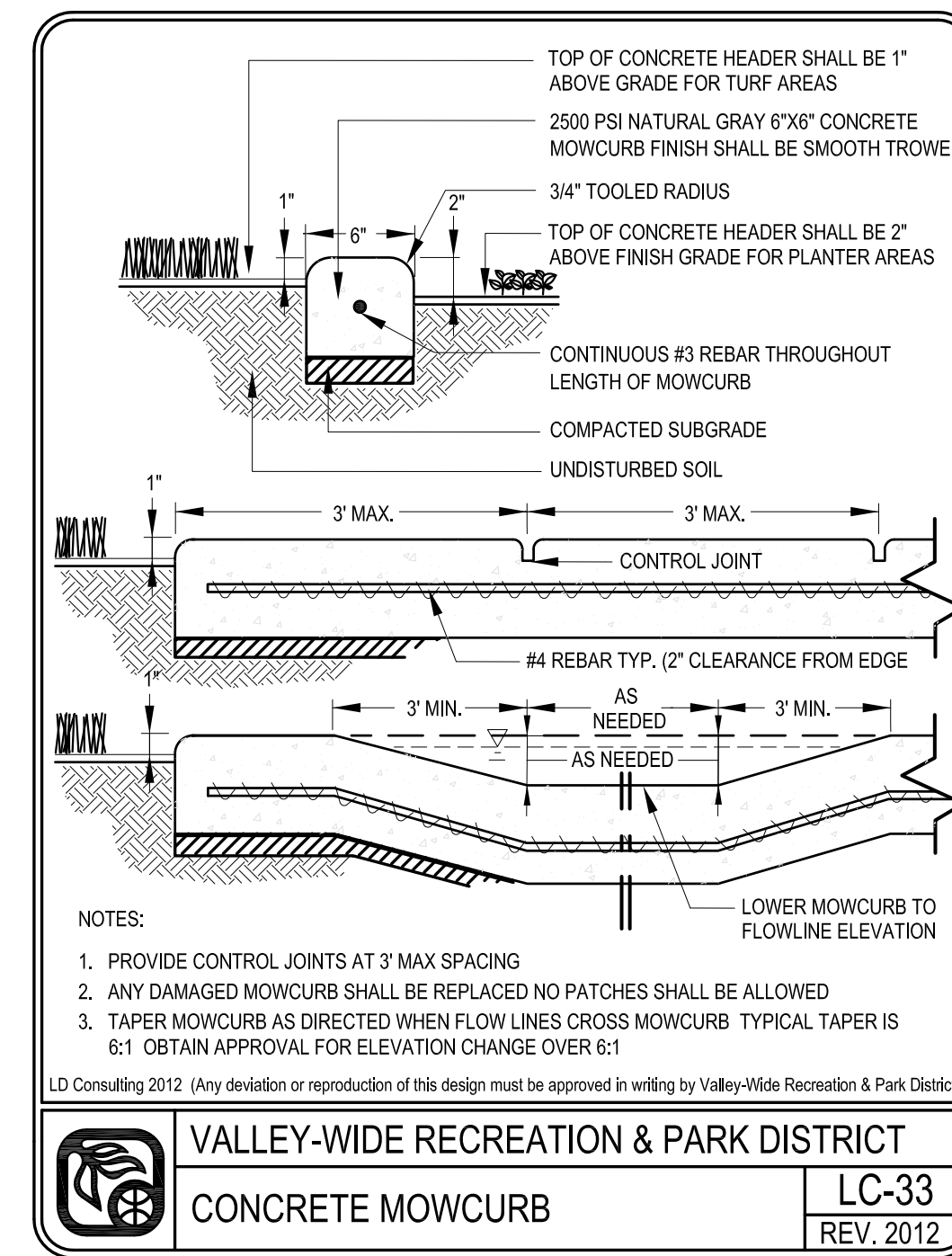
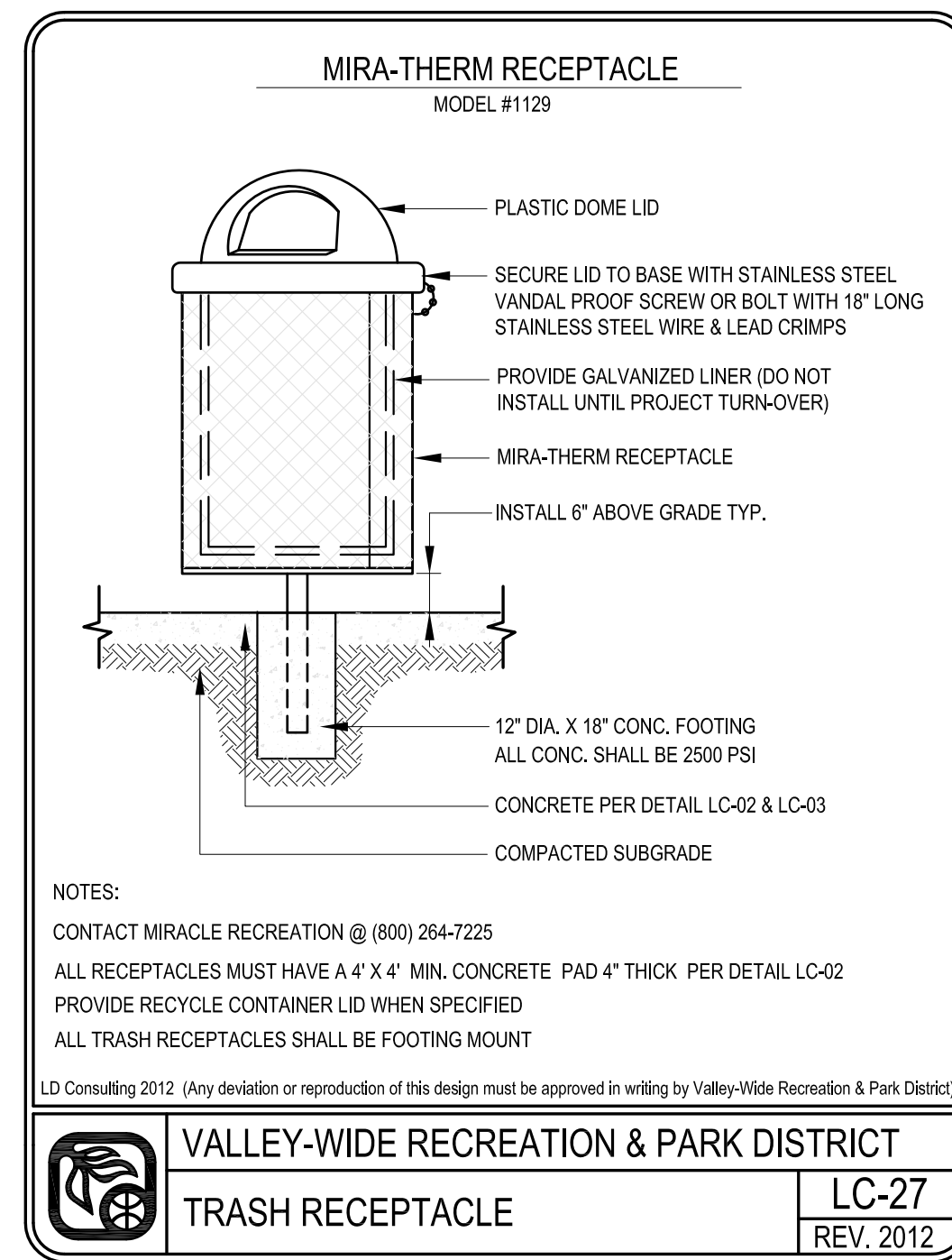
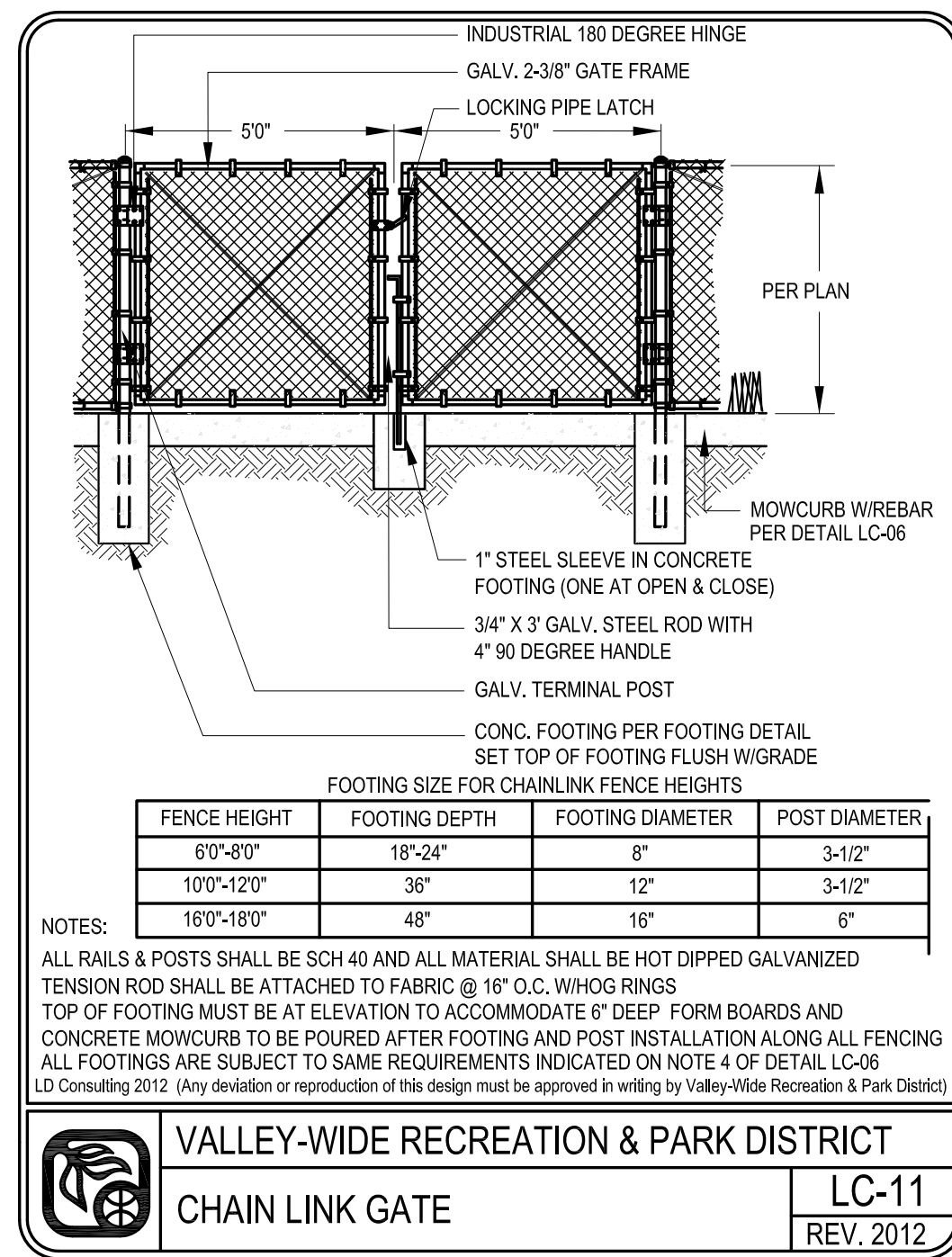
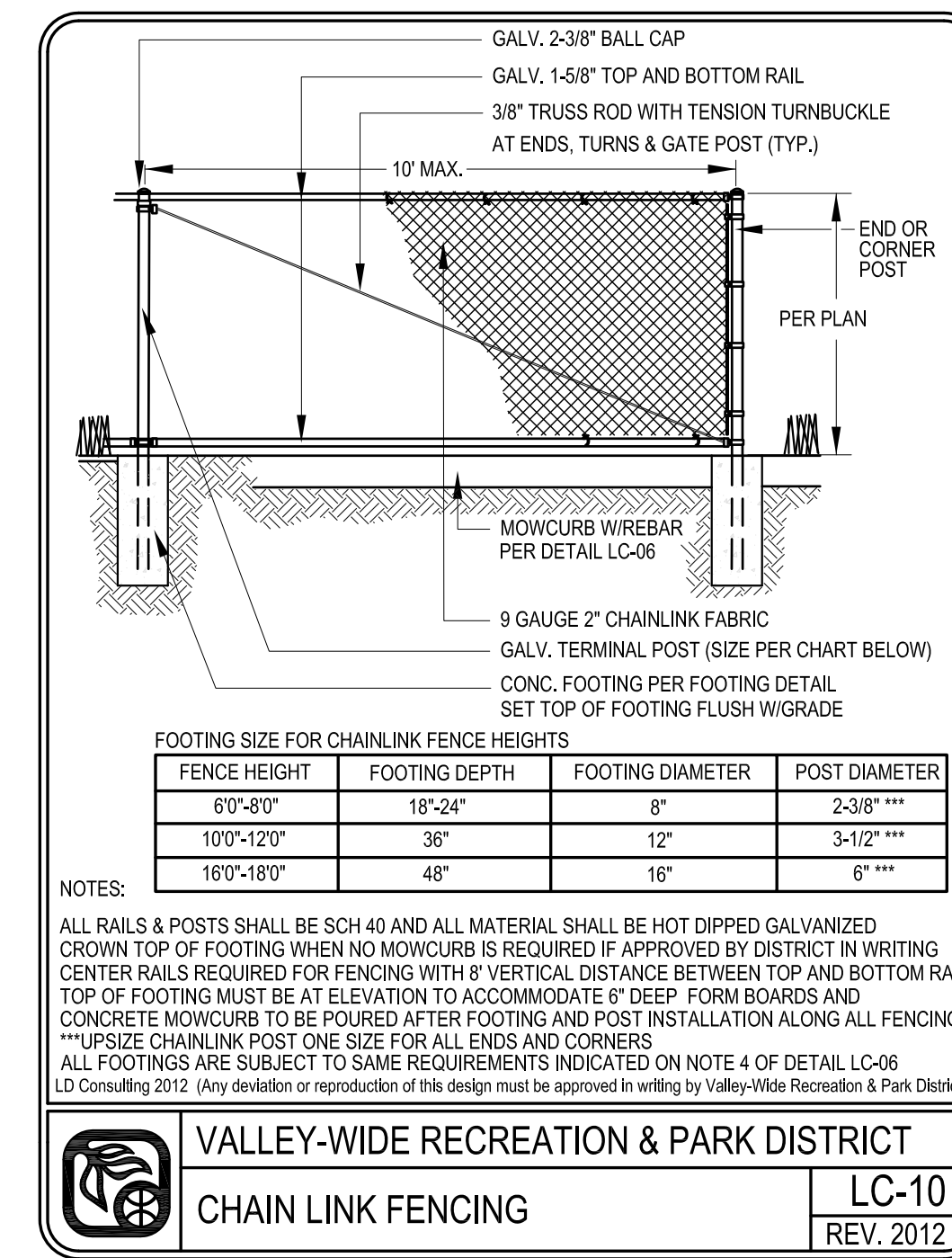
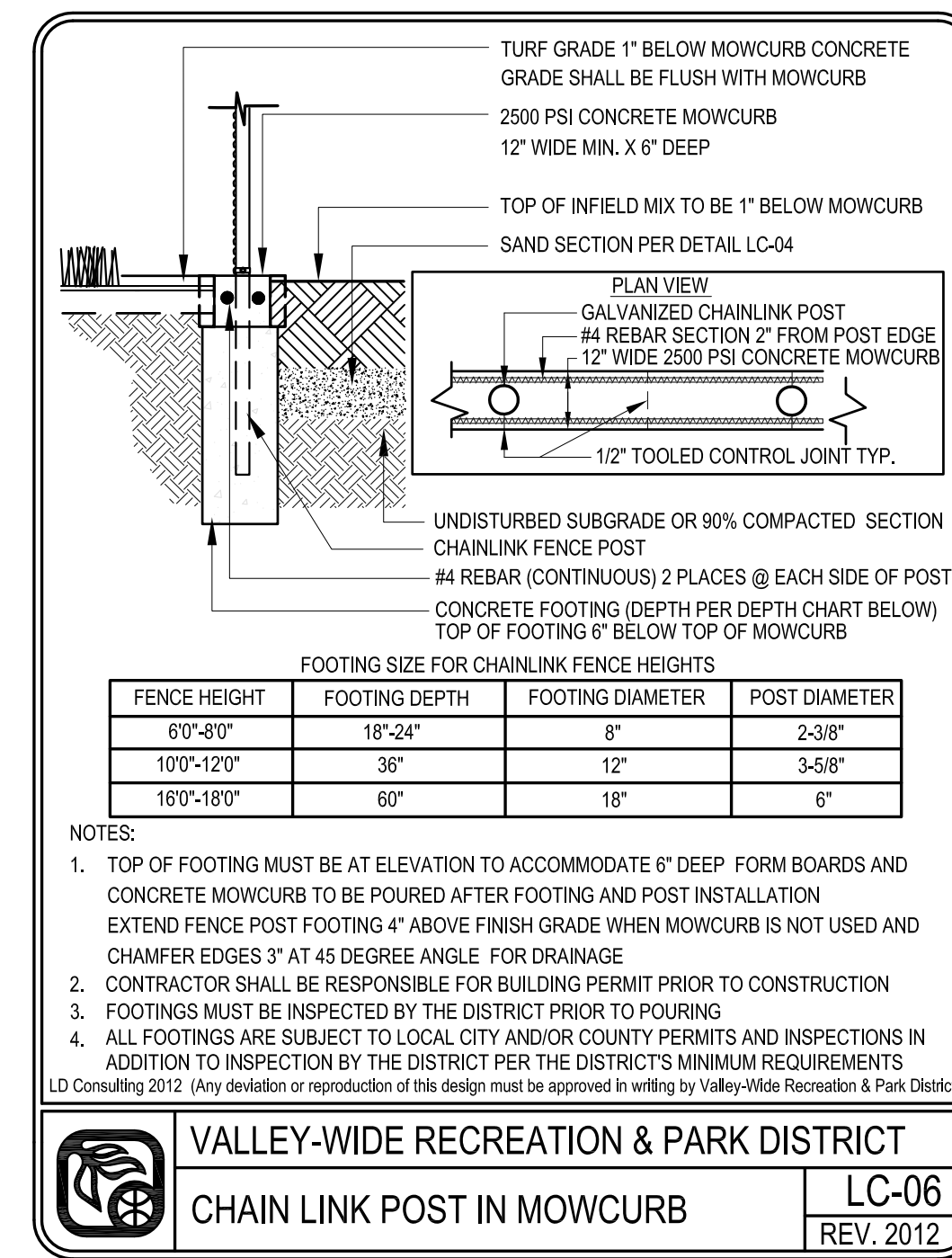
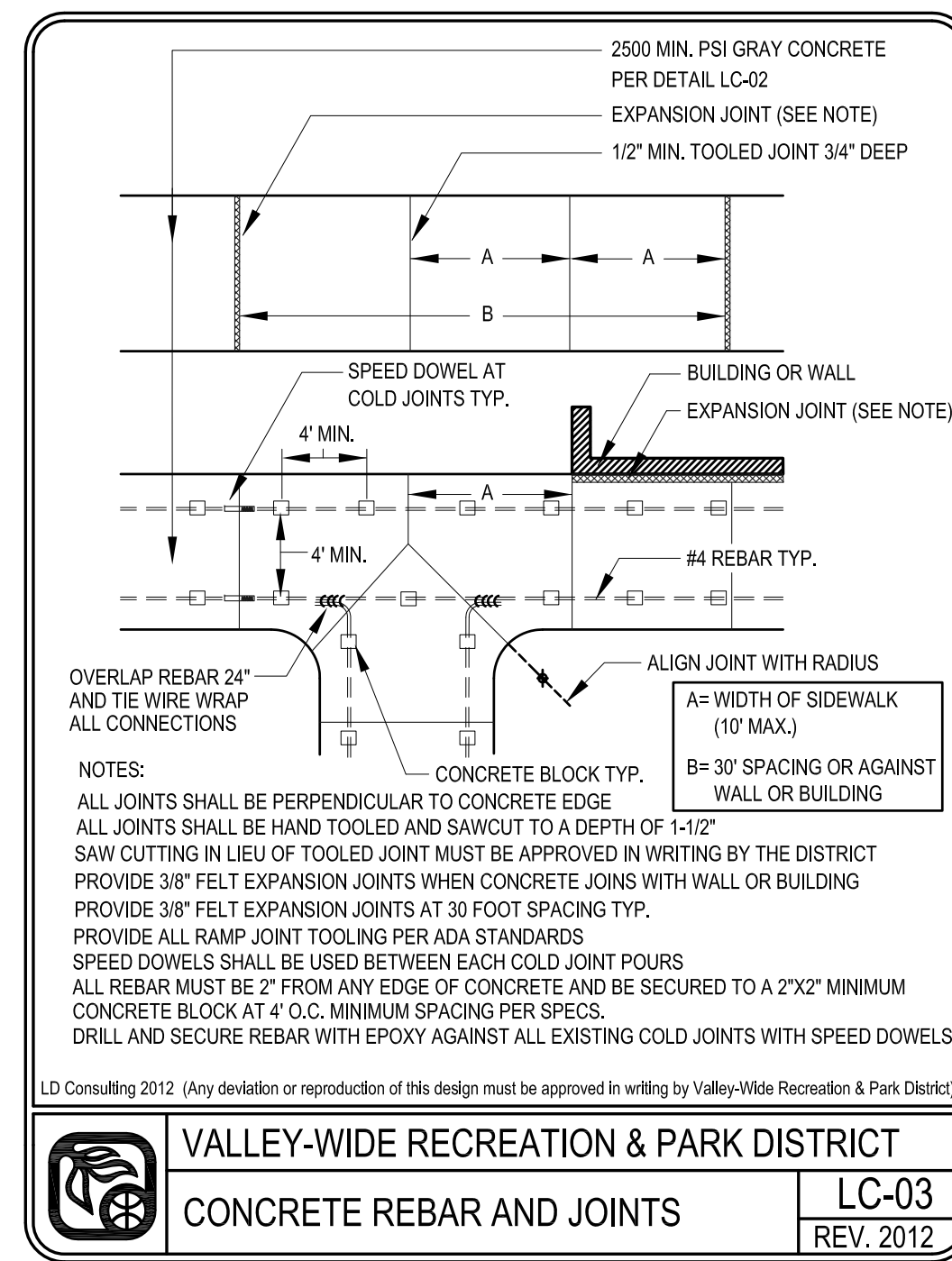
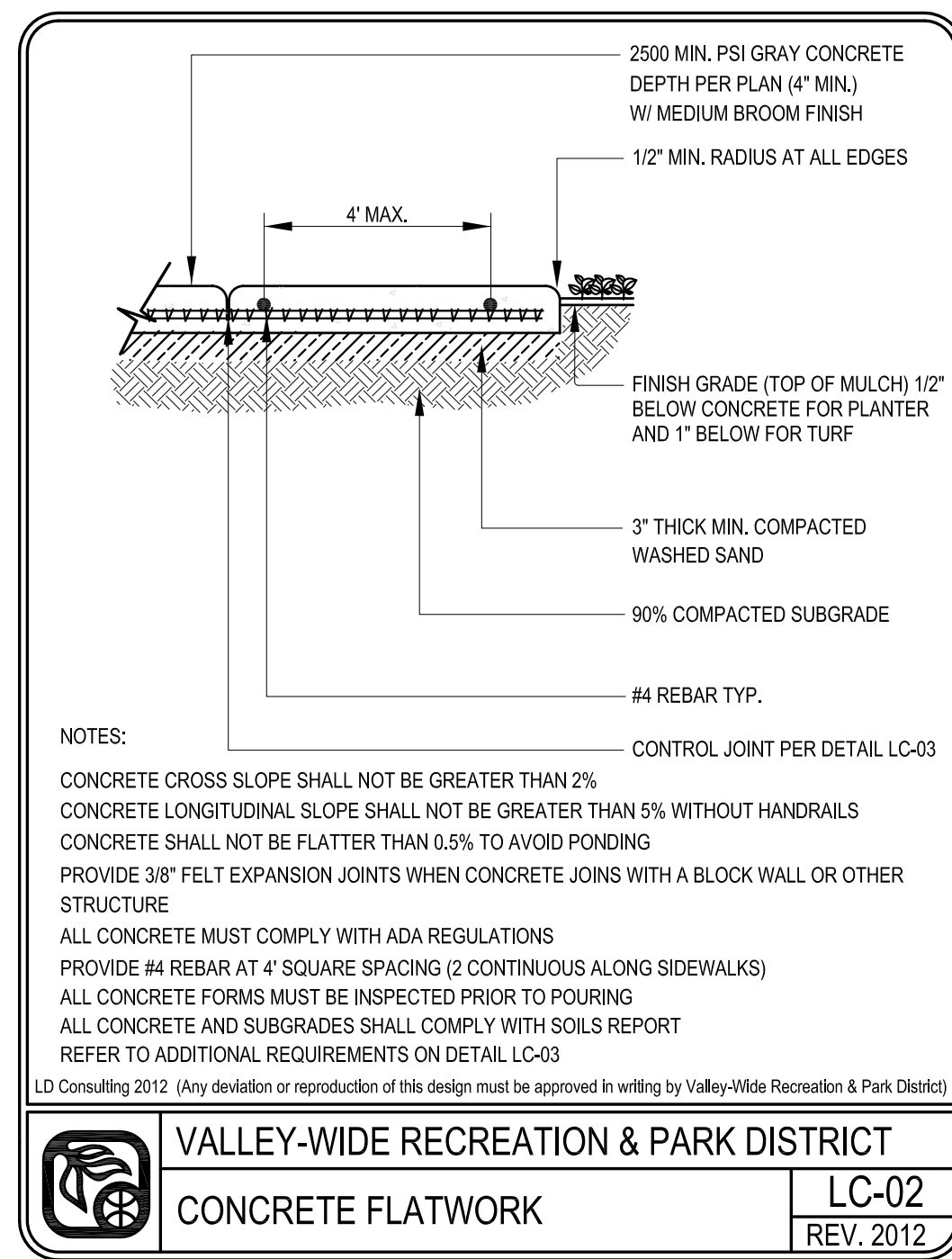

Underground Service Alert
Call: TOLL FREE
1-800-227-2600
TWO WORKING DAYS BEFORE YOU DIG

The private engineer signing these plans is responsible for assuring the accuracy and acceptability of the design hereon. In the event of discrepancies arising after city approval or during construction, the private engineer shall be responsible for determining an acceptable solution and revising the plans for approval by the City.

DATE	BY	MARK	REVISIONS	APPR.	DATE
DESIGNED BY	JP	DRAWN BY	JP	CHECKED BY	RA

CITY OF HEMET _____ DATE _____
R.C.E. NO. _____ EXP. DATE _____
APPROVED BY _____ DATE _____
RCE _____
R.C.E. NO. _____ EXP. DATE _____



VALLEY WIDE RECREATION & PARK DISTRICT
901 W. Esplanade Ave.
P.O. Box 907
San Jacinto, CA 92581
(951) 654-1505
(951) 654-5279 FAX

SIGNATURE: _____
DEAN WETTER _____ DATE _____

IN THE CITY OF HEMET
LANDSCAPE CONSTRUCTION PLAN
**DIAMOND VALLEY LAKE
PICKLEBALL COURTS**
1801 MARINA DR., HEMET, CA 92545
FOR VALLEY-WIDE W.O. 0000

SHEET NO. **LC-02**
OF 7 SHTS.
FILE NO.

IRRIGATION LEGEND

IRRIGATION LEGEND (POTABLE SYSTEM)			
SYMBOL	MAKER	MODEL NUMBER AND DESCRIPTION	DETAIL
◀	EXISTING	ISOLATION VALVE PER MAINLINE SIZE. INSTALL PER DETAILS AND REFER FOR MODEL AND TYPE AS FOLLOWS: - BRASS BALL VALVE - MODEL T-580 FOR MAINLINE 2" AND SMALLER.	IR-03 IR-04
⊙	EXISTING	QUICK COUPLING VALVE - 44DLRC W/ KEY LOCKING COVER. REFER TO IRRIGATION DETAIL AND SPECIFICATIONS.	IR-03
☼	RAINBIRD	DRIP REMOTE CONTROL VALVE - PESB. SEE PLAN FOR SIZE. INSTALL WITH 1" RAINBIRD QUICK CHECK BASKET FILTER MODEL OK-CHK-100 W/ 200 MESH STAINLESS STEEL SCREEN. RCVS WITH FLOWS GREATER THAN 20.1 GPM. CONTRACTOR TO INSTALL TWO 1" FILTERS PER IRRIGATION DETAILS.	IR-02 IR-07 IR-08
⊕	EXISTING	REMOTE CONTROL VALVE, QUICK COUPLER VALVE AND ISOLATION VALVE	IR-30 IR-35
⊞	SENNINGER	PRESSURE REGULATOR - CONTRACTOR SHALL USE THE FOLLOWING MODEL NUMBERS IN CORRELATION TO DRIP RCV FLOW. SEE DETAIL. - FOR RCVS W/ FLOW OF 0.5 TO 8 GPM CONTRACTOR SHALL INSTALL A SENNINGER PMR-30LF - FOR RCVS W/ FLOW OF 9 TO 20 GPM CONTRACTOR SHALL INSTALL A SENNINGER PMR-30MF - FOR RCVS W/ FLOW OF 31 TO 32 GPM CONTRACTOR SHALL INSTALL A SENNINGER PMR-30HF	IR-30 IR-35
▷	APPROVED	DRIP FLUSH VALVE. LOCATION, EACH FLUSH VALVE SHALL BE LABELED WITH ITS CORRESPONDING VALVE NUMBER FOR I.D. SEE DETAILS FOR FURTHER INFORMATION.	IR-34

IRRIGATION PIPING			
---	EXISTING	IRRIGATION MAINLINE - SLEEVE MAINLINE PER NOTES AND IRRIGATION DETAILS. FOR SIZES 1" - 1 1/2" USE POTABLE SCH. 40 PVC, SOLVENT WELD. FOR SIZES 2" - 3" USE POTABLE CLASS 315, SOLVENT WELD.	IR-23 IR-24
---	APPROVED	LATERAL PIPE - SLEEVE LATERALS PER NOTES AND IRRIGATION DETAILS. SIZE PER PLAN. - PVC SCH 40 IPS FOR LATERALS SIZES 3/4" TO 1 1/2". - PVC CLASS 315 IPS FOR LATERALS SIZES 2" AND LARGER.	IR-23
---	APPROVED	SHRUB DRIP LATERAL PIPE ON GRADE - UVR PROTECTED PIPE WITH UVR PROTECTED PVC SCH 40 FITTINGS. MINIMUM PIPE SIZE SHALL BE 7/8". PVC SCH 40 IPS LATERALS SIZES 3/4" TO 1 1/2". INSTALL WITH GPH IRRIGATION EMITTER MODEL #GSL220 PER VALLEY WIDE IRRIGATION DETAILS. CONTRACTOR SHALL INSTALL HEADER 3' OFF THE MAIN LATERAL FROM REMOTE CONTROL VALVE WITH SCH. 40 IPS PVC BURIED TO PREVENT TRIP HAZARDOUS. SIZE LATERALS PER PLAN. BURY ALL PIPE WITHIN 8" OF HARDSCAPE.	IR-30 IR-31 IR-32
---	APPROVED	TREE DRIP LATERAL PIPE ON GRADE - UVR PROTECTED PIPE WITH UVR PROTECTED PVC SCH 40 FITTINGS. MINIMUM PIPE SIZE SHALL BE 7/8". PVC SCH 40 IPS LATERALS SIZES 3/4" TO 1 1/2". INSTALL WITH GPH IRRIGATION EMITTER MODEL #GSL240 PER VALLEY WIDE IRRIGATION DETAILS. CONTRACTOR SHALL INSTALL HEADER 3' OFF THE MAIN LATERAL FROM REMOTE CONTROL VALVE WITH SCH. 40 IPS PVC BURIED TO PREVENT TRIP HAZARDOUS. SIZE LATERALS PER PLAN. BURY ALL PIPE WITHIN 8" OF HARDSCAPE.	IR-30 IR-31 IR-32 IR-33

IRRIGATION MISCELLANEOUS EQUIPMENT			
NO SYMBOL	AS APPROVED	CONTRACTOR SHALL INSTALL IRRIGATION CONTROL PILOT WIRES & EXTRA WIRES #14UF AWG DIRECT BURIAL (U.L. APPROVED). CONTRACTOR SHALL INSTALL COMMON WIRE #12UF AWG DIRECT BURIAL (U.L. APPROVED).	IR-23
NO SYMBOL	3M	DBVY-6 DIRECT BURIAL WATER-PROOF WIRE CONNECTORS FOR USE ON ALL WIRE CONNECTIONS.	IR-28
NO SYMBOL	AS APPROVED	INSTALL THRUST BLOCK ON ALL CHANGE OF DIRECTION OF MAINLINE.	IR-24

VALVE KEY:		
VALVE NUMBER	GPM	PIPE SIZE
5-9 GPM		3/4" PVC
8.1-13 GPM		1" PVC
13.1-22 GPM		1 1/4" PVC
22.1-30 GPM		1 1/2" PVC

IRRIGATION POINT-OF-CONNECTION NOTES:

CONNECT NEW VALVE TO EXISTING 2" POTABLE WATER MAINLINE, PROVIDED AND INSTALLED BY OTHERS. VERIFY EXISTING IRRIGATION CONTROLLER CAN HOUSE ALL EXISTING EXTRA WIRES BEFORE COMMENCEMENT OF THE PROJECT. OTHERWISE IMMEDIATELY CONTACT THE LANDSCAPE DESIGNER FOR ADDITIONAL DIRECTIVE.

OBSERVATION SCHEDULE

THE LANDSCAPE CONTRACTOR SHALL BE RESPONSIBLE TO SCHEDULE AN IRRIGATION OBSERVATION REVIEW BY VALLEY WIDE FOR THE FOLLOWING ITEMS:

- * PRE-JOB
- * MAINLINE LAYOUT, FILTER/BASKET STRAINER, QUICK COUPLERS, REMOTE CONTROL VALVES AND WIRES PRIOR TO BACKFILLING TRENCHES, AND MAINLINE PRESSURE TEST.

IRRIGATION MAINLINE

THE IRRIGATION MAINLINE IS SHOWN DIAGRAMMATIC FOR CLARITY PURPOSE ONLY. ALL IRRIGATION MAINLINE SHALL BE STAKED/ CHALKED IN THE FIELD FOR REVIEW AND APPROVAL BY THE OWNER'S REPRESENTATIVE PRIOR TO INSTALLATION.

INSTALLATION NOTE

THE CONTRACTOR SHALL REFER TO THE LATEST EDITION OF THE VALLEY-WIDE RECREATION AND PARK DISTRICT STANDARDS MANUAL AND DESIGN GUIDELINES. REFER TO IRRIGATION DETAILS AND NOTES FOR ADDITIONAL INFORMATION.

HOLD HARMLESS & INDEMNIFICATION CLAUSE

CONTRACTOR AGREES TO ASSUME SOLE RESPONSIBILITY FOR JOB SITE CONDITIONS DURING THE COURSE OF CONSTRUCTION OF THIS PROJECT, INCLUDING SAFETY OF ALL PERSONS AND PROPERTY; THAT THIS REQUIREMENT SHALL APPLY CONTINUOUSLY AND NOT BE LIMITED TO NORMAL WORKING HOURS, AND THAT THE CONTRACTOR SHALL DEFEND, INDEMNIFY, AND HOLD THE OWNER/DEVELOPER, THE COUNTY OF LOCAL JURISDICTION AND THE LANDSCAPE DESIGNER HARMLESS FROM ANY AND ALL LIABILITY REAL OR ALLEGED, IN CONNECTION WITH THE PERFORMANCE OF WORK ON THIS PROJECT, EXCEPTING FOR LIABILITY ARISING FROM SOLE NEGLIGENCE OF THE OWNER/DEVELOPER, COUNTY OF LOCAL JURISDICTION AND THE LANDSCAPE DESIGNER.

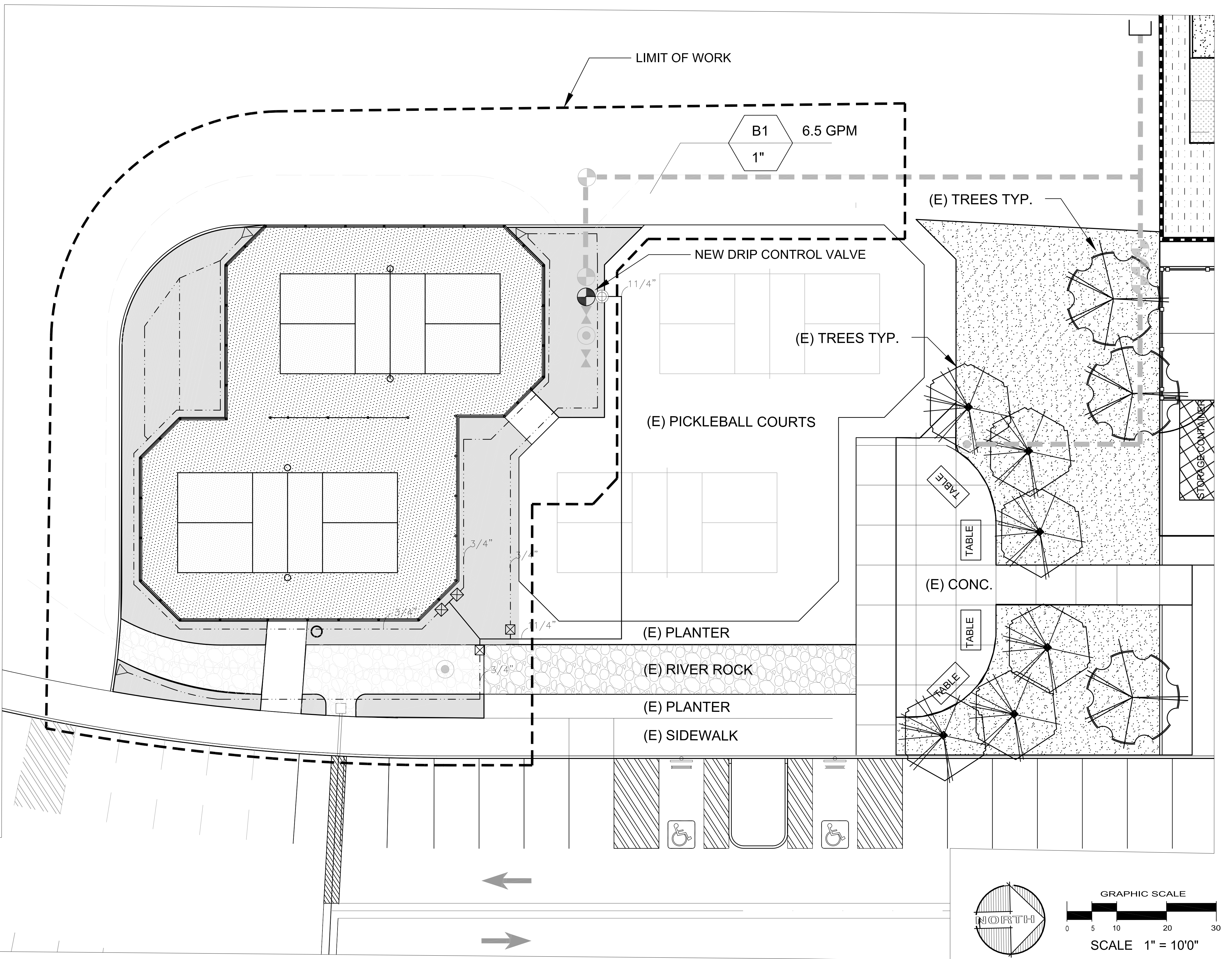

Underground Service Alert
 Call: TOLL FREE
 1-800-227-2600
 TWO WORKING DAYS BEFORE YOU DIG

DATE BY MARK APPR. DATE
 ENGINEER REVISIONS CITY
 DESIGNED BY JP DRAWN BY JP CHECKED BY RA

DATE	BY	MARK	APPR.	DATE

CITY OF HEMET DATE _____
 R.C.E. NO. _____ EXP. DATE _____

APPROVED BY DATE _____
 R.C.E. NO. _____ EXP. DATE _____

VALLEY WIDE RECREATION & PARK DISTRICT
 901 W. Esplanade Ave.
 P.O. Box 907
 San Jacinto, CA 92581
 (951) 654-1505
 (951) 654-5279 FAX

SIGNATURE: _____ DATE _____
 DEAN WETTER

IN THE CITY OF HEMET
 LANDSCAPE IRRIGATION PLAN
DIAMOND VALLEY LAKE PICKLEBALL COURTS
 1801 MARINA DR., HEMET, CA 92545

FOR VALLEY-WIDE W.O. 0000

SHEET NO. **IR-01**
 OF ____ SHTS.
 FILE NO. _____

2-19-18

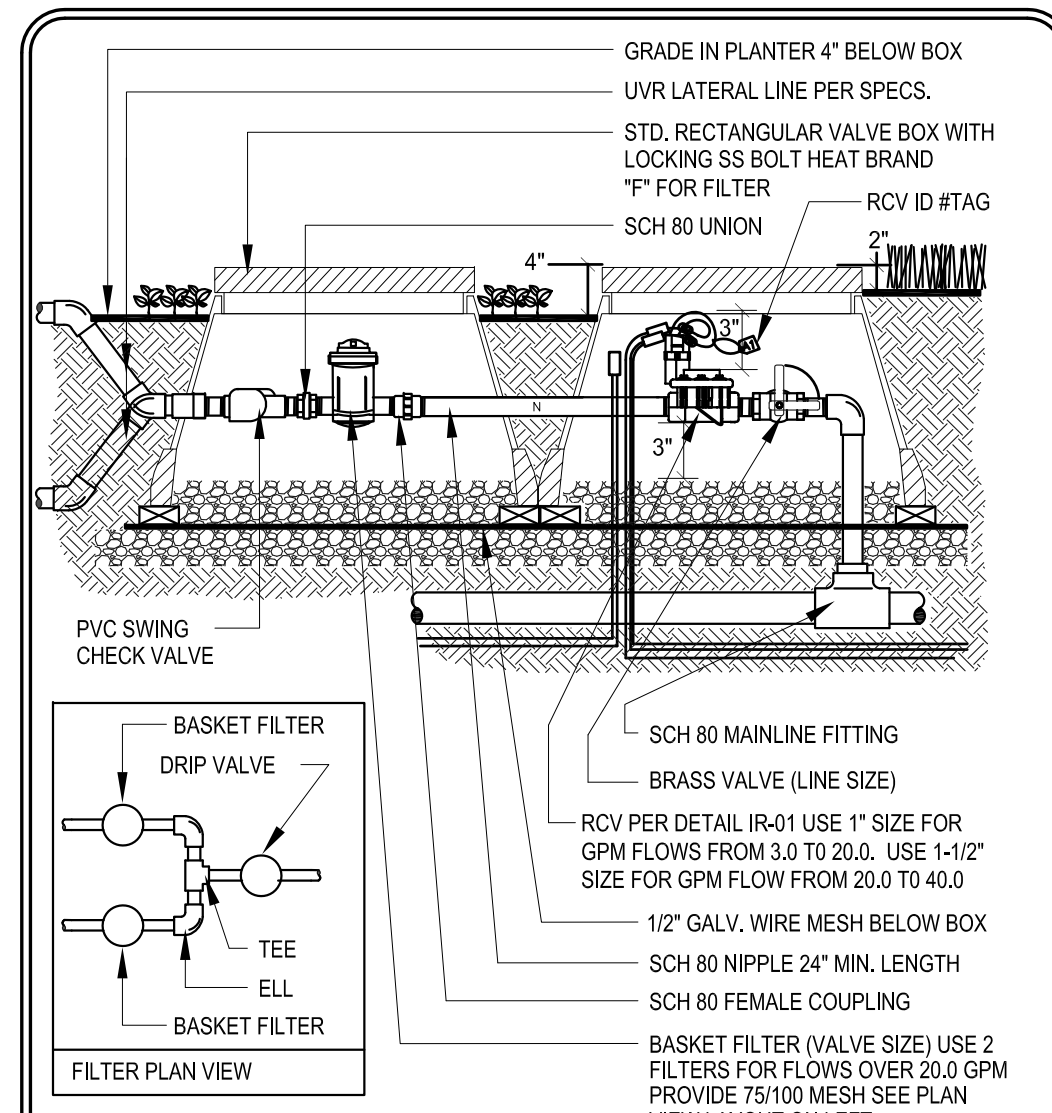

LD Consulting 2012 (Any deviation or reproduction of this design must be approved in writing by Valley-Wide Recreation & Park District)

VALLEY-WIDE RECREATION & PARK DISTRICT

DRIP REMOTE CONTROL VALVE

IR-02
REV. 2012

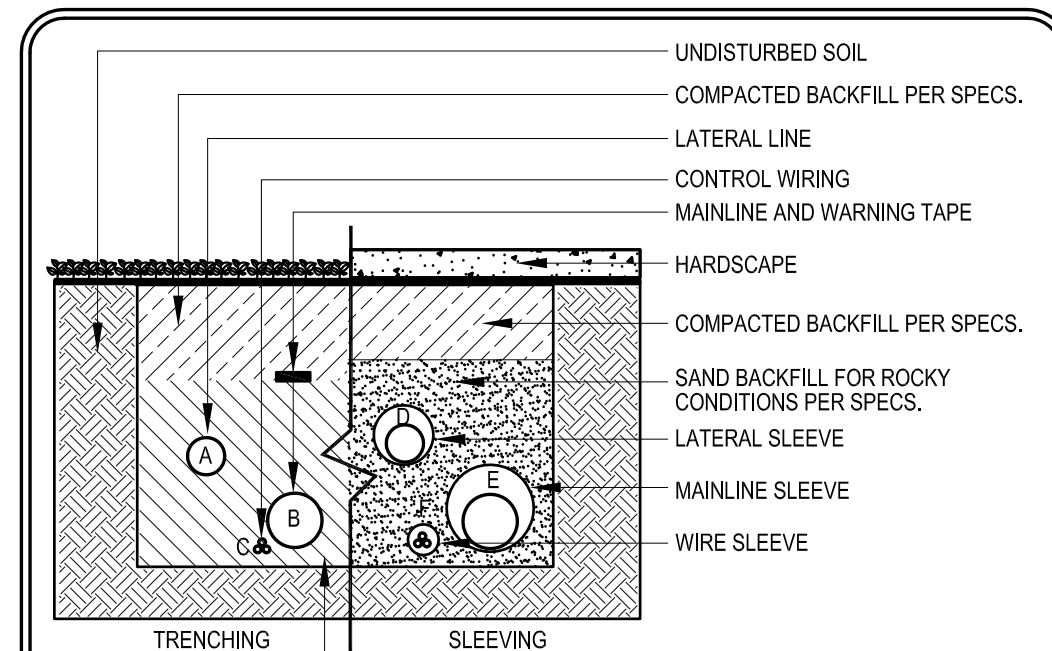

LD Consulting 2012 (Any deviation or reproduction of this design must be approved in writing by Valley-Wide Recreation & Park District)

VALLEY-WIDE RECREATION & PARK DISTRICT

TRENCHING & SLEEVING

IR-23
REV. 2012

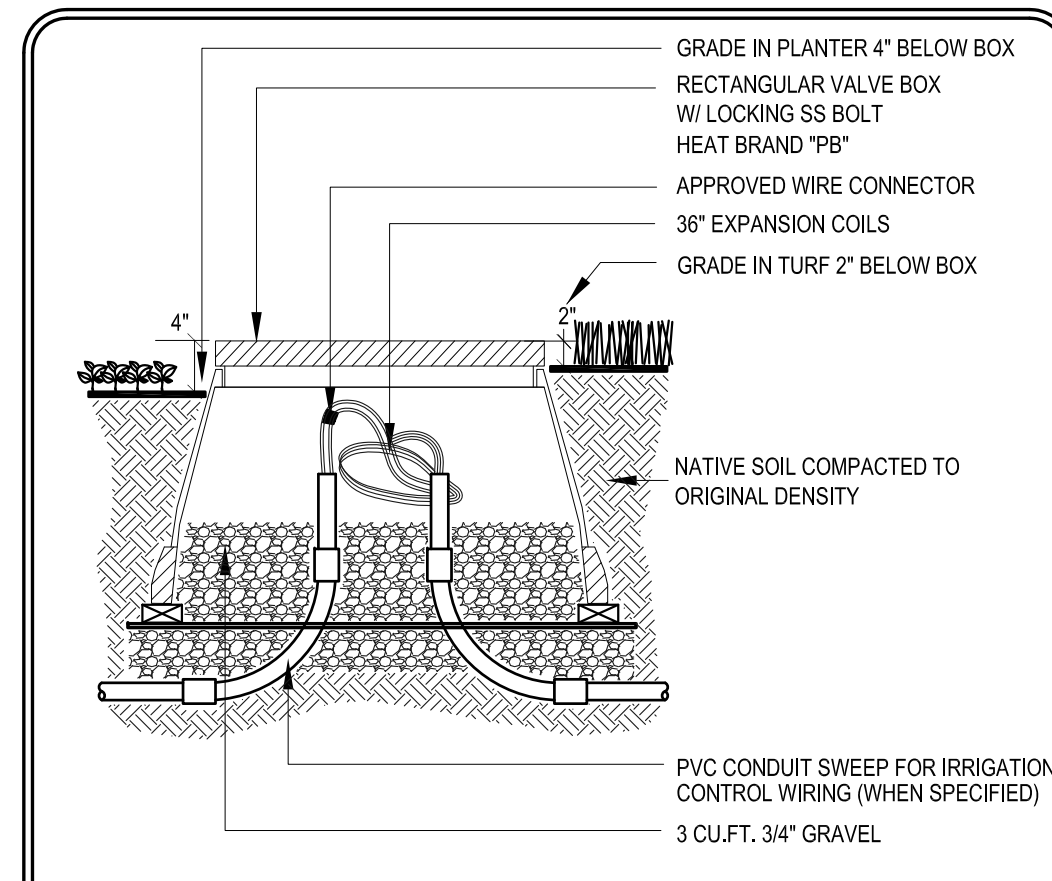

LD Consulting 2012 (Any deviation or reproduction of this design must be approved in writing by Valley-Wide Recreation & Park District)

VALLEY-WIDE RECREATION & PARK DISTRICT

PULL BOX

IR-27
REV. 2012

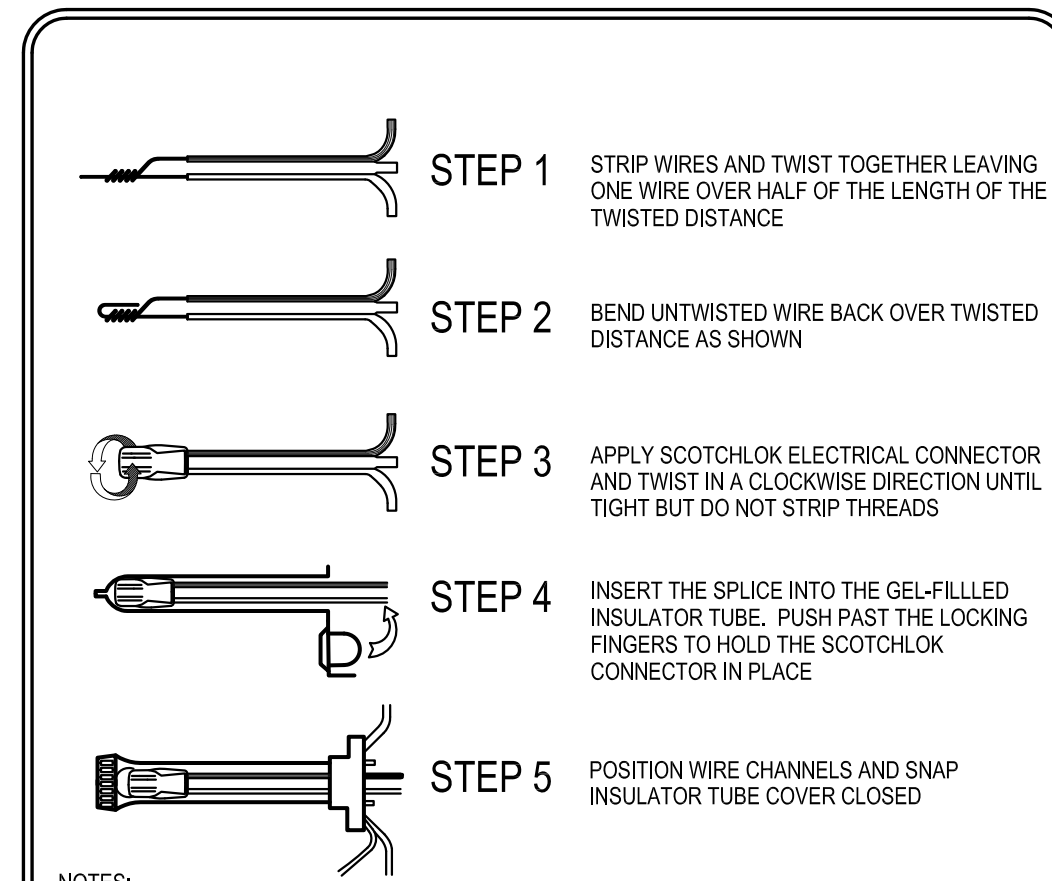

LD Consulting 2012 (Any deviation or reproduction of this design must be approved in writing by Valley-Wide Recreation & Park District)

VALLEY-WIDE RECREATION & PARK DISTRICT

WIRE CONNECTORS

IR-28
REV. 2012

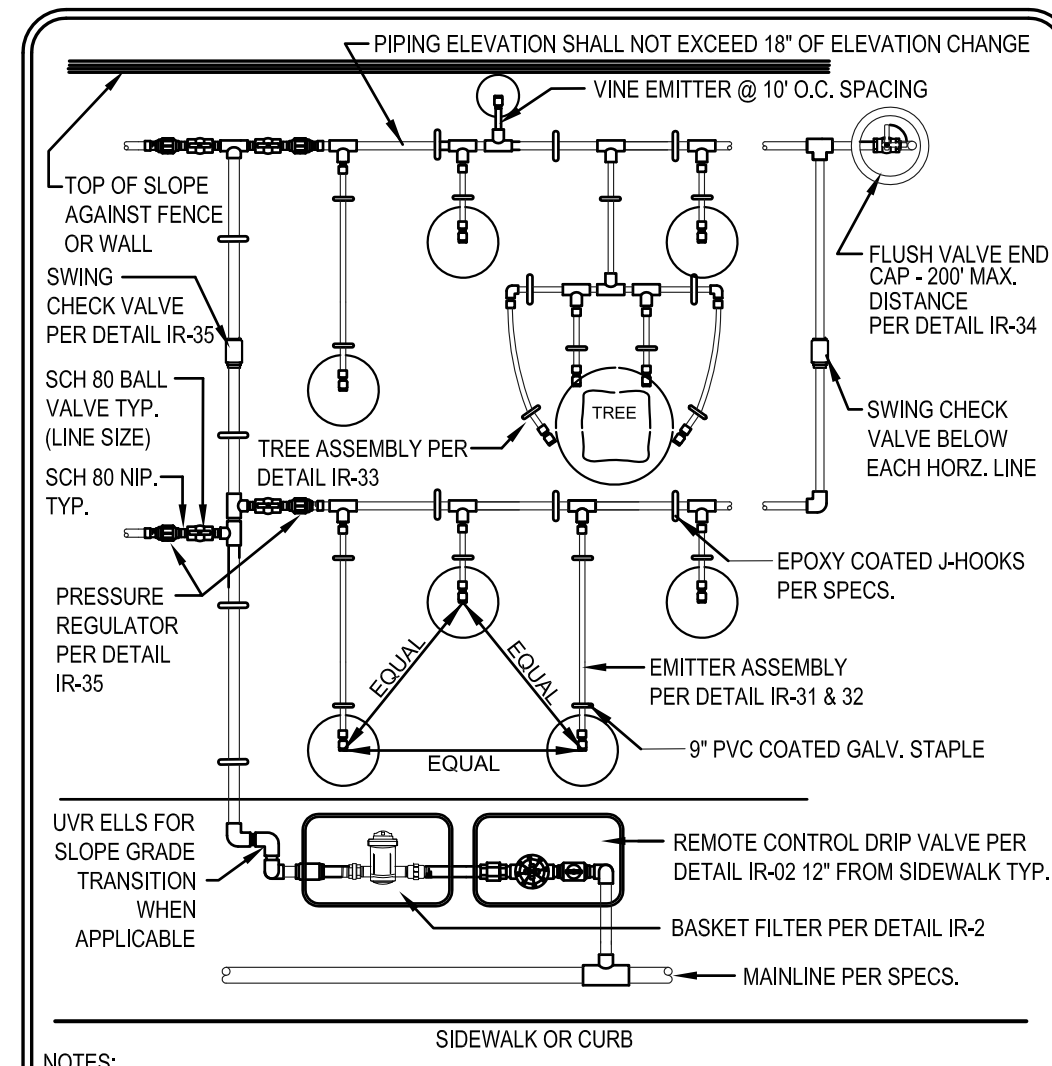

LD Consulting 2012 (Any deviation or reproduction of this design must be approved in writing by Valley-Wide Recreation & Park District)

VALLEY-WIDE RECREATION & PARK DISTRICT

POINT TO POINT LATERAL LAYOUT

IR-30
REV. 2012

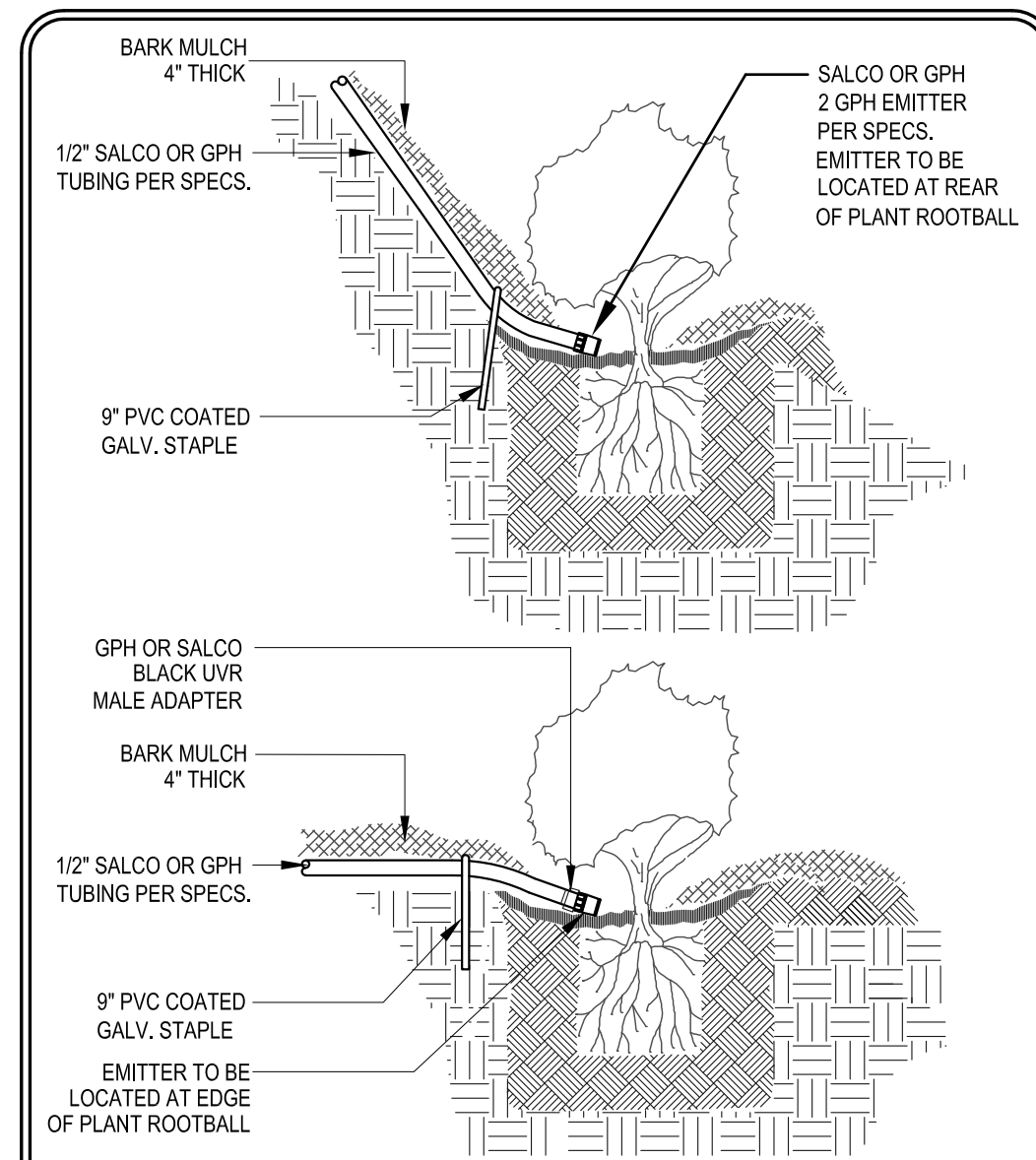

LD Consulting 2012 (Any deviation or reproduction of this design must be approved in writing by Valley-Wide Recreation & Park District)

VALLEY-WIDE RECREATION & PARK DISTRICT

EMITTER ASSEMBLY SECTION VIEW

IR-31
REV. 2012

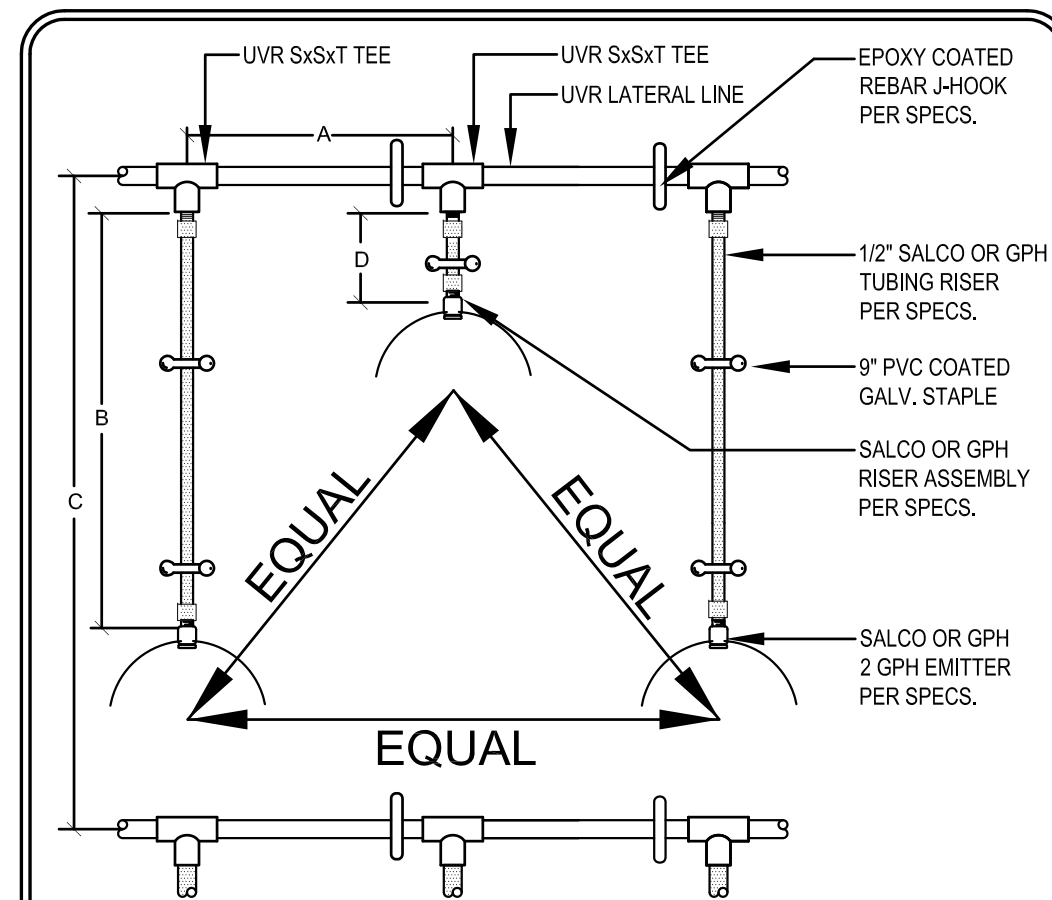

LD Consulting 2012 (Any deviation or reproduction of this design must be approved in writing by Valley-Wide Recreation & Park District)

VALLEY-WIDE RECREATION & PARK DISTRICT

SHRUB EMITTER ASSEMBLY LAYOUT

IR-32
REV. 2012

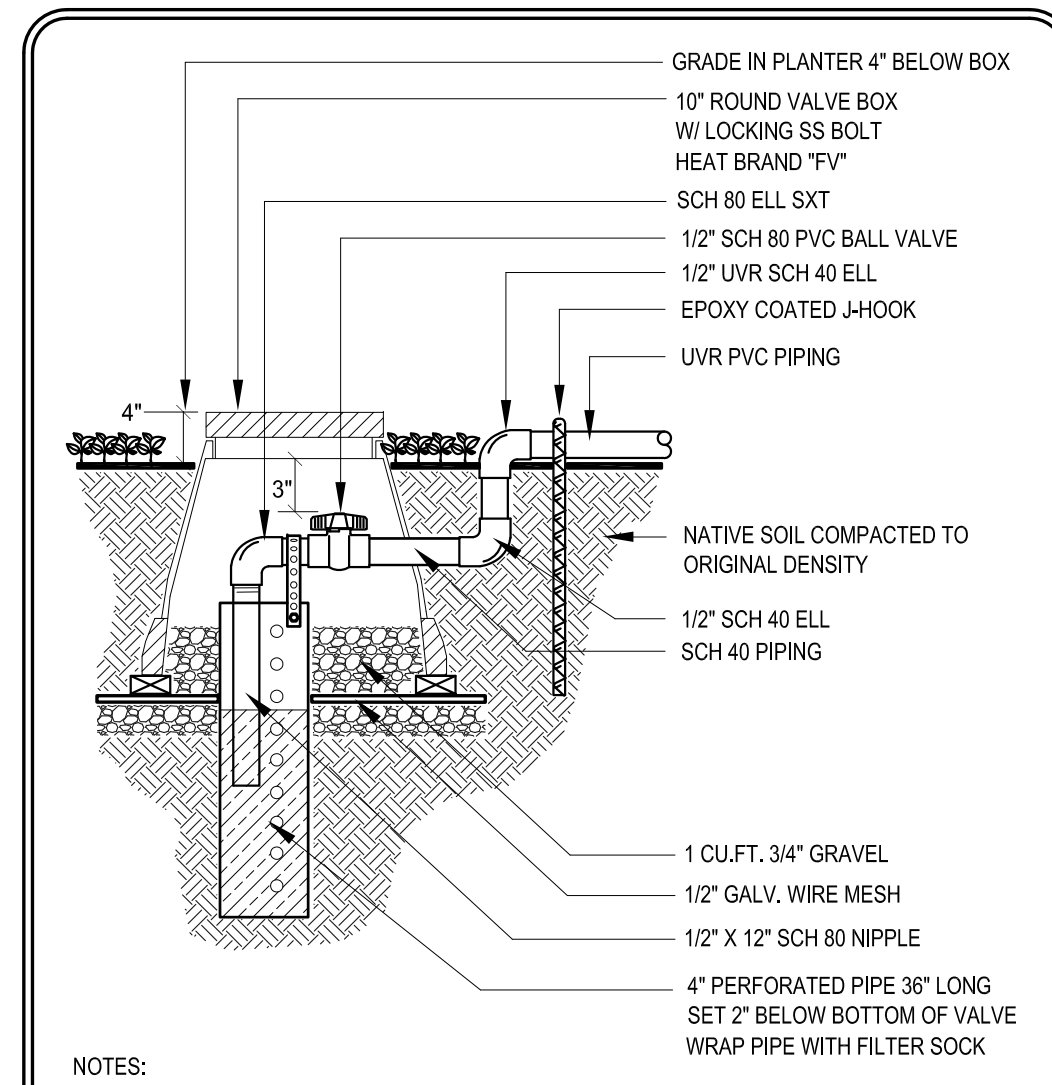

LD Consulting 2012 (Any deviation or reproduction of this design must be approved in writing by Valley-Wide Recreation & Park District)

VALLEY-WIDE RECREATION & PARK DISTRICT

FLUSH VALVE ASSEMBLY

IR-34
REV. 2012

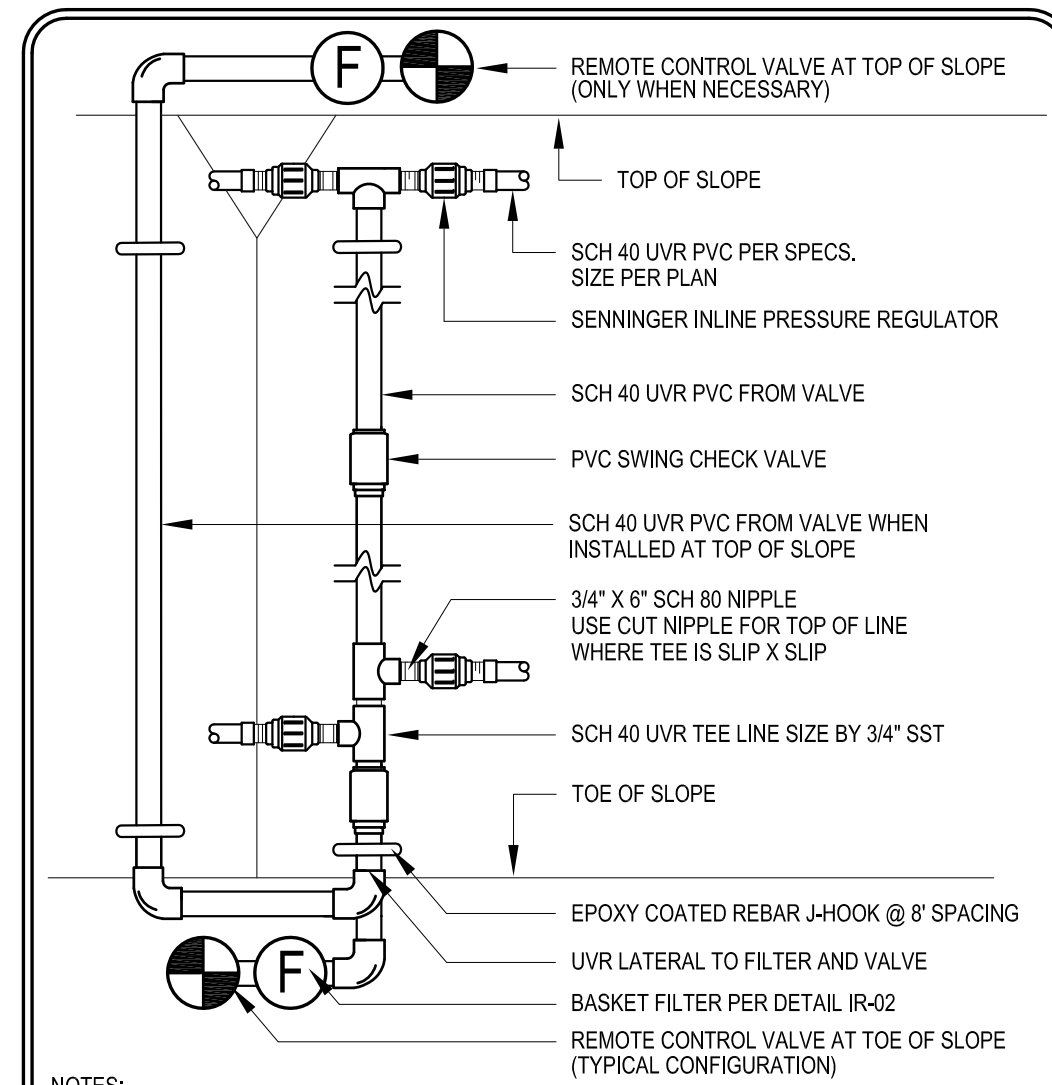

LD Consulting 2012 (Any deviation or reproduction of this design must be approved in writing by Valley-Wide Recreation & Park District)

VALLEY-WIDE RECREATION & PARK DISTRICT

CHECK VALVE & PRESSURE REG.

IR-35
REV. 2012

Underground Service Alert
Call: TOLL FREE
1-800-227-2600
TWO WORKING DAYS BEFORE YOU DIG

The private engineer signing these plans is responsible for assuring the accuracy and acceptability of the design hereon. In the event of discrepancies arising after city approval or during construction, the private engineer shall be responsible for determining an acceptable solution and revising the plans for approval by the City.

DATE	BY	MARK	REVISIONS	APPR.	DATE
DESIGNED BY	JP	DRAWN BY	JP	CHECKED BY	RA

VALLEY-WIDE RECREATION & PARK DISTRICT

CITY OF HEMET

DATE _____

R.C.E. NO. _____ EXP. DATE _____

APPROVED BY _____ DATE _____

R.C.E. NO. _____ EXP. DATE _____

VALLEY WIDE RECREATION & PARK DISTRICT
901 W. Esplanade Ave.
P.O. Box 907
San Jacinto, CA 92581
(951) 654-1505
(951) 654-5279 FAX

SIGNATURE: _____ DATE _____

DEAN WETTER

IN THE CITY OF HEMET
LANDSCAPE IRRIGATION PLAN
DIAMOND VALLEY LAKE
PICKLEBALL COURTS
1801 MARINA DR., HEMET, CA 92545

FOR VALLEY-WIDE

W.O. 0000

SHEET NO. **IR-02**
OF ___ SHTS.
FILE NO.

PLANTING LEGEND

QTY.	SIZE	BOTANICAL NAME	COMMON NAME	WATER	DETAIL
1	36" BOX	QUERCUS VIRGINIANA	SOUTHERN OAK	LOW	PL-02
70	5 GAL.	PHOTINIA FRASERI	RED TIP PHOTINIA	MED	PL-04
15	5 GAL.	PYRACANTHA SANTA CRUZ	SANTA CRUZ FIRETHORN	MED	PL-04
40	5 GAL.	LOMANDRA LONGIFOLIA	DWARF MAT RUSH	MED	PL-04
21	5 GAL.	WESTRINGA FRUTICOSA	COASTAL ROSEMARY	LOW	PL-04
22	1 GAL.	ROSMARINUS OFFICINALIS	TRAILING ROSEMARY	LOW	PL-04
20	1 GAL.	TULHBAGIA VIOLACEA	SOCIETY GARLIC	MED	PL-04
PER PLAN	4" THICK	BARK MULCH	APPROVED BY VWRPD		PL-07
PER PLAN	6"-8"	8" DEEP ARIZONA RIVER ROCK	APPROVED BY VWRPD		

PLANTING NOTES

1. ALL WORK MUST CONFORM TO VALLEY-WIDE'S CURRENT LANDSCAPE STANDARDS.
2. CONTRACTOR SHALL VERIFY ALL QUANTITIES ON PLAN WITH LEGEND.
3. PROVIDE ROOT BARRIER FOR ALL TREES WITHIN 8" OF HARDSCAPE PER DETAIL PL-9.
4. MULCH SAMPLES MUST BE APPROVED BY VALLEY-WIDE PRIOR TO INSTALLATION.
5. CONTRACTOR SHALL CALL FOR THE FOLLOWING INSPECTIONS:

FINISH GRADE PRIOR TO PLANTING
 SOIL PREPARATION
 WEEDABATEMENT OBSERVATION
 TREE & SHRUB LAYOUT
 GRADE PRIOR TO HYDROSEEDING
 COMPLETION (MAINT. START)
 MONTHLY MAINT. WALK
 FINAL WALK

VALLEY-WIDE INSPECTION DEPT.
 CALL (951) 660-4700

48 HOUR NOTICE FOR INSPECTIONS
 7 DAY NOTICE FOR FINAL WALK.

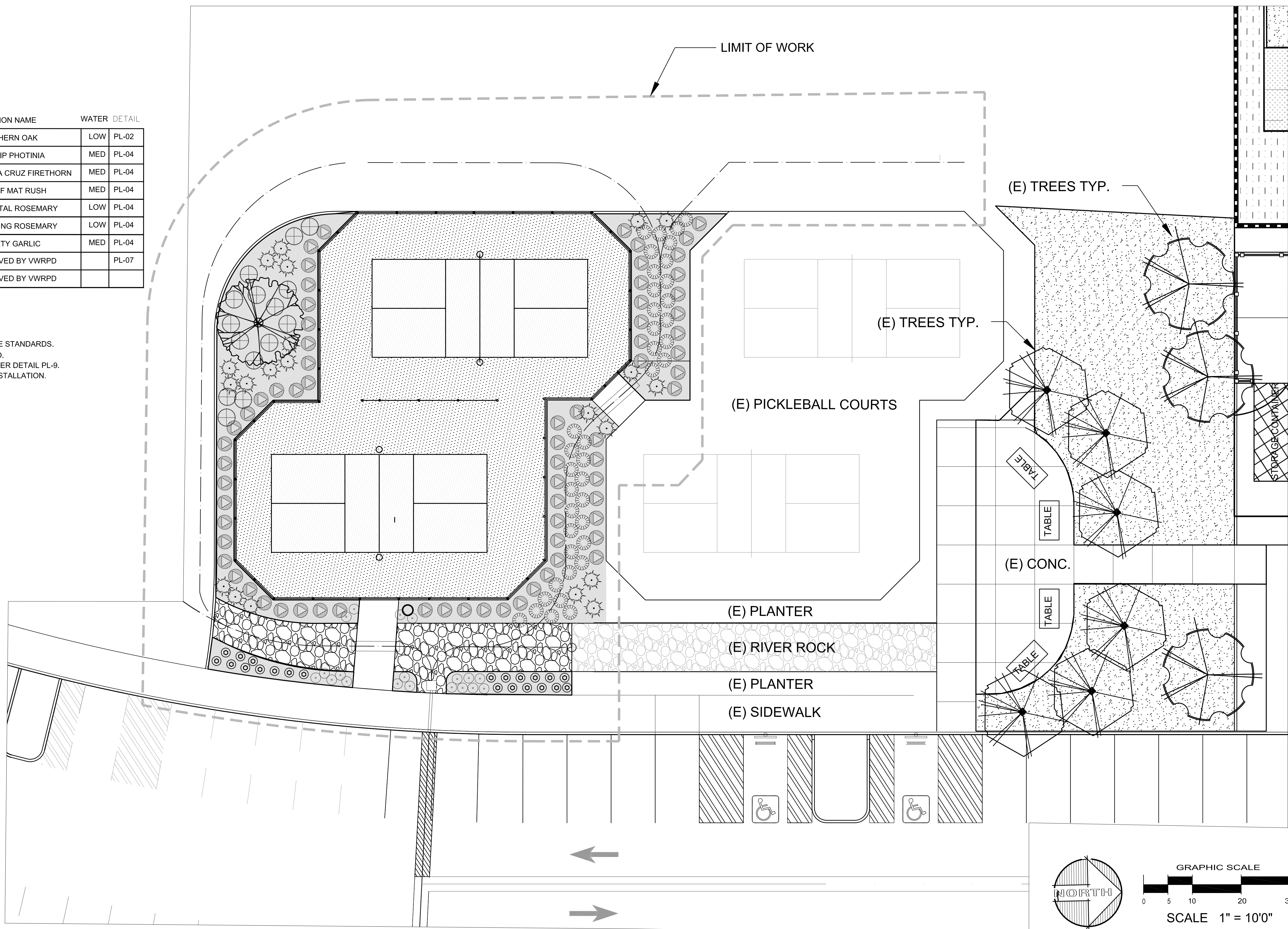

HOLD HARMLESS & INDEMNIFICATION CLAUSE

CONTRACTOR AGREES TO ASSUME SOLE RESPONSIBILITY FOR JOB SITE CONDITIONS DURING THE COURSE OF CONSTRUCTION OF THIS PROJECT, INCLUDING SAFETY OF ALL PERSONS AND PROPERTY; THAT THIS REQUIREMENT SHALL APPLY CONTINUOUSLY AND NOT BE LIMITED TO NORMAL WORKING HOURS, AND THAT THE CONTRACTOR SHALL DEFEND, INDEMNIFY, AND HOLD THE OWNER/DEVELOPER, THE COUNTY OF LOCAL JURISDICTION AND THE LANDSCAPE DESIGNER HARMLESS FROM ANY AND ALL LIABILITY REAL OR ALLEGED, IN CONNECTION WITH THE PERFORMANCE OF WORK ON THIS PROJECT, EXCEPTING FOR LIABILITY ARISING FROM SOLE NEGLIGENCE OF THE OWNER/DEVELOPER, COUNTY OF LOCAL JURISDICTION AND THE LANDSCAPE DESIGNER.

Underground Service Alert
 Call: TOLL FREE
 1-800-227-2600
 TWO WORKING DAYS BEFORE YOU DIG

The private engineer signing these plans is responsible for assuring the accuracy and acceptability of the design hereon. In the event of discrepancies arising after city approval or during construction, the private engineer shall be responsible for determining an acceptable solution and revising the plans for approval by the City.

DATE	BY	MARK	REVISIONS	APPR.	DATE
DESIGNED BY	JP	DRAWN BY	JP	CHECKED BY	RA

CITY OF HEMET DATE _____
 R.C.E. NO. _____ EXP. DATE _____
 APPROVED BY DATE _____
 R.C.E. NO. _____ EXP. DATE _____



VALLEY WIDE RECREATION & PARK DISTRICT
 901 W. Esplanade Ave.
 P.O. Box 907
 San Jacinto, CA 92581
 (951) 654-1505
 (951) 654-5279 FAX

SIGNATURE: _____ DATE _____
 DEAN WETTER

IN THE CITY OF HEMET
LANDSCAPE PLANTING PLAN
DIAMOND VALLEY LAKE
PICKLEBALL COURTS
 1801 MARINA DR., HEMET, CA 92545
 FOR VALLEY-WIDE W.O. 0000

SHEET NO. **PL-01**
 OF ___ SHTS.
 FILE NO. _____

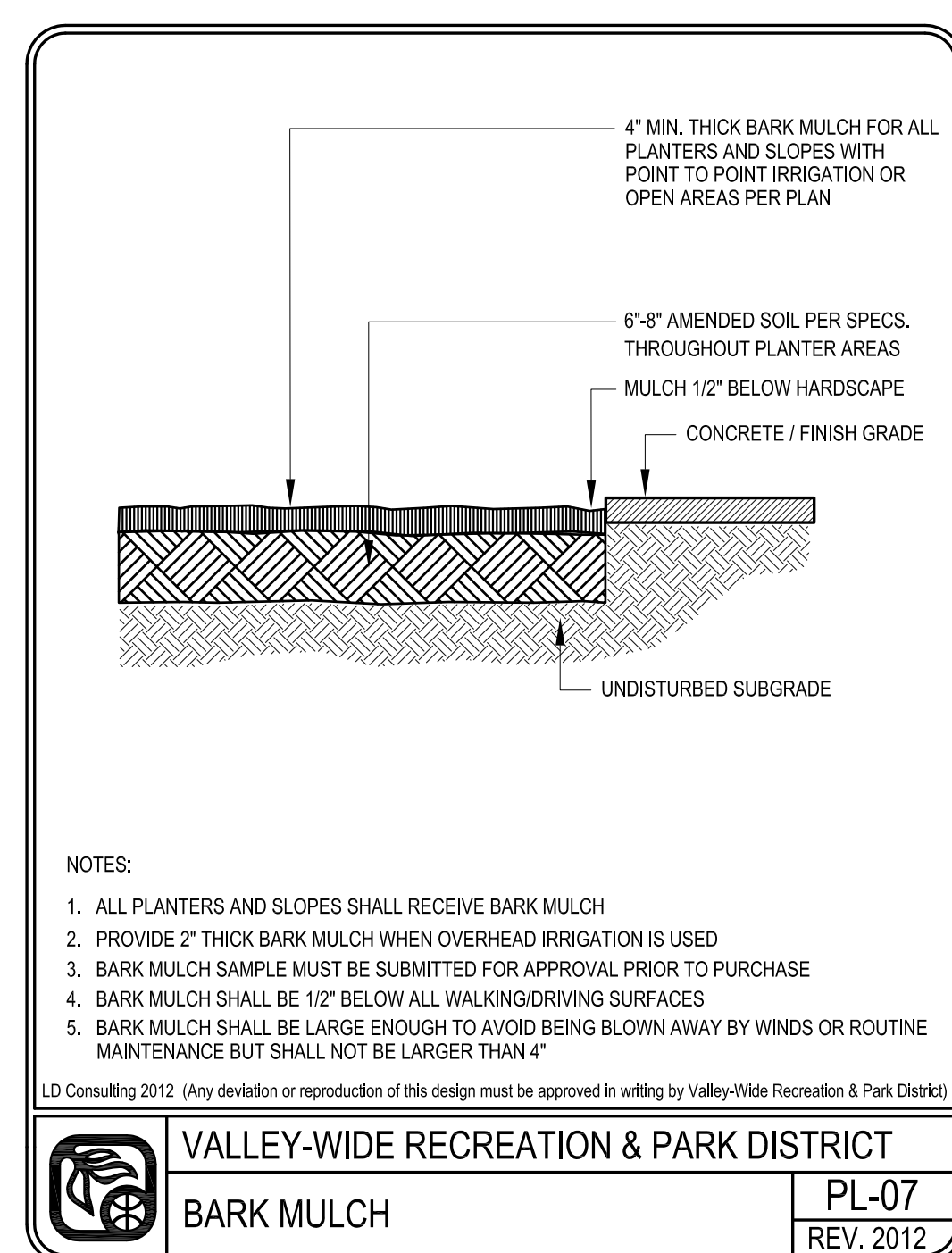
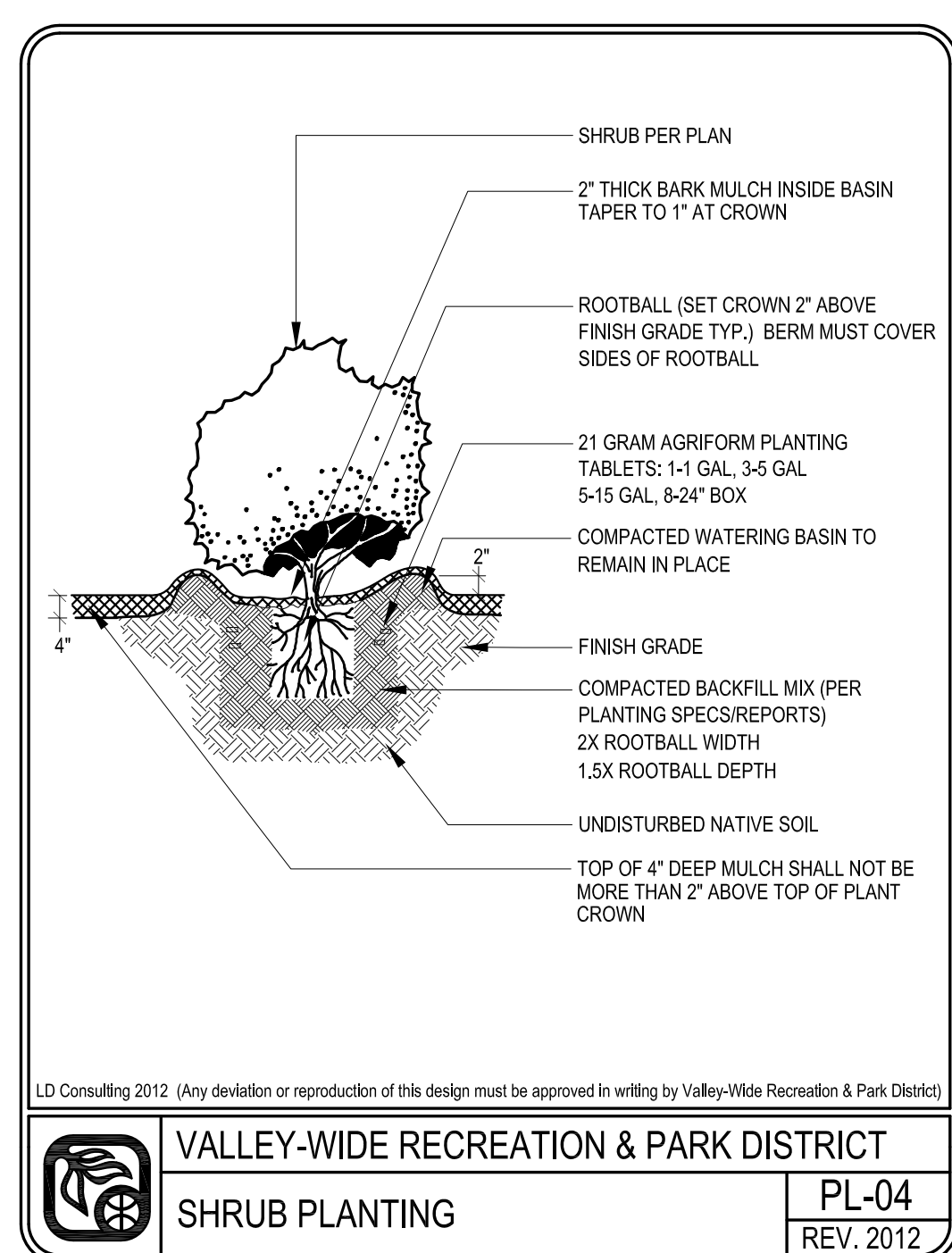
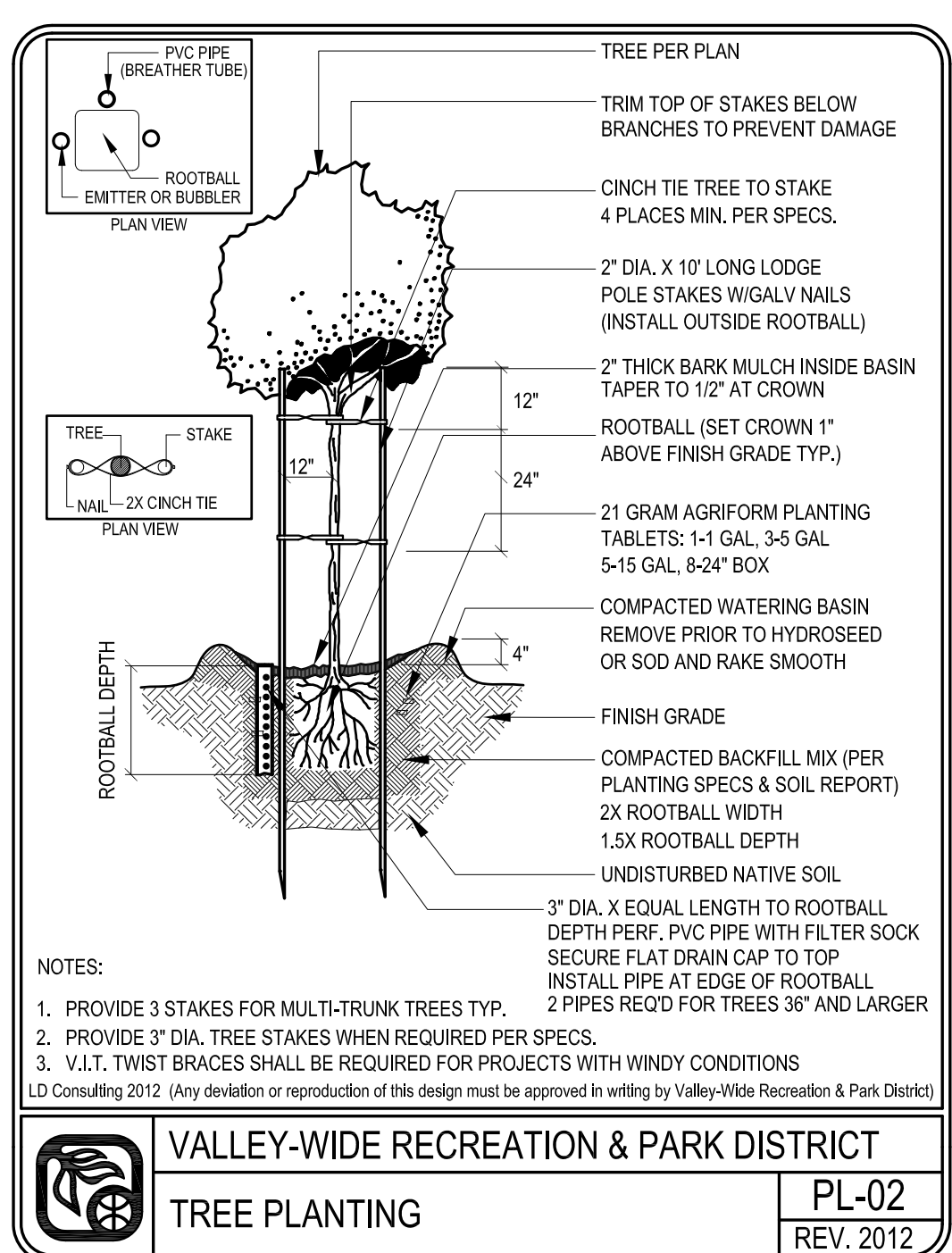

NOTES:
1. PROVIDE 3 STAKES FOR MULTI-TRUNK TREES TYP.
2. PROVIDE 3\"/>

LD Consulting 2012 (Any deviation or reproduction of this design must be approved in writing by Valley-Wide Recreation & Park District)

NOTES:
1. ALL PLANTERS AND SLOPES SHALL RECEIVE BARK MULCH
2. PROVIDE 2\"/>

LD Consulting 2012 (Any deviation or reproduction of this design must be approved in writing by Valley-Wide Recreation & Park District)

VALLEY-WIDE RECREATION & PARK DISTRICT
TREE PLANTING PL-02
REV. 2012

VALLEY-WIDE RECREATION & PARK DISTRICT
SHRUB PLANTING PL-04
REV. 2012

VALLEY-WIDE RECREATION & PARK DISTRICT
BARK MULCH PL-07
REV. 2012

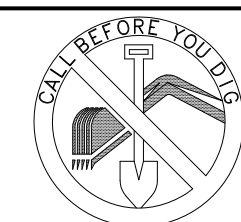

Underground Service Alert
Call: TOLL FREE
1-800-227-2600
TWO WORKING DAYS BEFORE YOU DIG

The private engineer signing these plans is responsible for assuring the accuracy and acceptability of the design hereon. In the event of discrepancies arising after city approval or during construction, the private engineer shall be responsible for determining an acceptable solution and revising the plans for approval by the City.

DATE	BY	MARK	REVISIONS	APPR.	DATE

DESIGNED BY	JP	DRAWN BY	JP	CHECKED BY	RA
-------------	----	----------	----	------------	----

CITY OF HEMET _____ DATE _____

APPROVED BY _____ DATE _____

FOR _____ DATE _____



VALLEY WIDE RECREATION & PARK DISTRICT
901 W. Esplanade Ave.
P.O. Box 907
San Jacinto, CA 92581
(951) 654-1505
(951) 654-5279 FAX

SIGNATURE: _____

DEAN WETTER

DATE

IN THE CITY OF HEMET
LANDSCAPE PLANTING PLAN
DIAMOND VALLEY LAKE
PICKLEBALL COURTS
1801 MARINA DR., HEMET, CA 92545

FOR VALLEY-WIDE

W.O. 0000

SHEET NO. **PL-02**
OF ___ SHTS.
FILE NO. _____



Standard Specifications

PLANTING

CONTENTS

PART 1- Planting Specifications GENERAL	1-2
PART 2-Planting Specifications MATERIAL	2-3
PART 3-Planting Specifications EXECUTION	3-7
PART 4-Planting Specifications MAINTENANCE.....	7-9

PLANTING

PART 1-PLANTING SPECIFICATIONS: GENERAL

1. General Requirements:

- a. Permits: Contractor shall obtain and pay for any permits required.
- b. All irrigation shall be completed, approved and under automatic operation for a minimum of 7 days prior to any planting.

2. Scope Of Work:

- a. The intent of the drawings and specifications is to indicate the processes required for the installation of a complete planting without additional cost in labor and material to the Owner.

3. Inspections:

- a. Request for inspections must have 48 hour notice in advance.
- b. Contractor must be on site for all inspections.
- c. Any work not completed when inspector arrives which was requested for, shall be billed to the contractor at the current inspector's rate.
- d. Any work completed without inspection or approval shall be removed, exposed or replaced at the cost of the contractor.
- e. Contractor shall call for inspection for the following items:
 - i. Final grading
 - ii. Weed Abatement Observation
 - iii. Tree and shrub layout
 - iv. Tree and shrub planting pits
 - v. Finish grade prior to hydroseeding
 - vi. Final Inspection

4. Submittals:

- a. All submittals shall be submitted within 15 days after receipt of executed contract.
- b. Contract shall submit the follow items but not limited to:
 - i. Plant material proof of purchase with listed nurseries and material sizes for approval
 - ii. All soil amendments
 - iii. Bark mulch
 - iv. Soil report

- v. Labels for all herbicide and fertilizers used
- vi. Hydroseed mix

PART 2-PLANTING SPECIFICATIONS: MATERIALS

1. Plant Material:

- a. All plant material shall be the same as specified in the drawings.
- b. Contractor shall tag one plant from each bundle or lot with the plant name in accordance with the recommendations of the American Association of Nurserymen.
- c. All plant material shall be free of pest, plant diseases abrasions or any other objectionable disfigurements.
- d. Plant material must show vigorous habit of growth that is normal for that particular species.

2. Tree Stakes:

- a. Tree stakes shall be copper maphthanate, green color impregnated lodge pole pine.
- b. Tree stake shall be 2" in diameter 10 feet long
- c. Tree ties shall be V.I.T. cinch ties or approved equal four per tree typ.
- d. tree ties shall be attached to lodge poles with galvanized nails per detail.

3. Vine Ties:

- a. Vine ties shall be as specified in details

4. Herbicides:

- a. Contractor shall submit labels of all herbicides used prior to application for approval.
- b. Contractor shall apply pre-emergent herbicide to all areas possible as recommended by a licensed pest control consultant.

5. Concrete Mow Curb:

- a. Concrete mow curb shall be 2500 psi concrete and as specified in detail.

6. Redwood Headerboard:

- a. Redwood headerboard shall be grade A fine redwood and as specified in detail.

7. Plant Tablets:

- a. Planting tablets shall be as specified in detail.
8. **Soil Conditioners:**
- a. All soil conditioner material shall be approved prior to ordering under this section.
 - b. Soil conditioners shall be based on soil report recommendations.

PART 3-PLANTING SPECIFICATIONS: EXECUTION

1. **Installation:**
- a. Contractor shall clean, remove legally dispose of all weeds, grasses including roots and construction debris under this section.
 - b. Contractor shall be responsible for the protection and storage of all material for the project.
 - c. All grades shall be as indicated on the drawings and must be +/-10%.
2. **Landscape Grading:**
- a. The contractor shall complete grading and filling as needed or remove additional dirt, rock and debris over 3/4 inch in diameter within the top 3 inches in all turf and planter areas less than 3:1.
 - b. Contractor shall bring all landscaped areas to finish grade.
 - c. Flow lines shall be established to existing curbs and/or sidewalks.
 - d. All landscape areas shall be sloped to provide positive drainage.
3. **Soil Preparation:**
- a. Contractor shall rototill amendments into all turf and planter areas 3:1 or less throughout the first 6 inches.
 - b. The following application rate is for bidding purposed only and is per 1000 square feet of planting area.
 - i. 4 cubic yards of soil conditioner
 - ii. 30 lbs. of commercial fertilizer approved by the Owner's representative
 - iii. 50 lbs. of agriculture grade gypsum
 - iv. 25 lbs. soil sulfur

- c. Actual soil preparation shall be based on the soil report.
- d. Soil samples shall be taken in the presence of the Owner's representative.
- e. Contractor shall submit soil samples to an approved laboratory testing facility.
- f. Contractor shall provide one soil report for every 50,000 square feet.
- g. Soil recommendations must be separated for turf, planter, slope and plant material backfill mix.

4. Weed Abatement:

- a. Weed abatement shall not commence until complete irrigation system is under complete automatic irrigation and has been approved.
- b. Upon completion of soil preparation the contractor shall complete the following:
 - i. Irrigate all areas to be planted, sodded or seeded for a period of seven days to germinate all weed seeds.
 - ii. Cut watering and apply approved weed killer per manufacture's recommendations and allow adequate time to complete kill.
 - iii. Repeat step one and two.
 - iv. Obtain approval of completed weed abatement prior to any planting. Trees may be planted prior to weed abatement process with the approval of the Owner's representative in writing.

5. Layout:

- a. Contractor shall layout all tree and shrubs for approval from the Owner's representative prior to excavating any planting pits.
- b. Contractor shall not willfully layout any planting material where obstructions exist. The contractor shall notify the engineer to obtain direction.

6. Planting:

- a. Planting shall be as shown in detail and as follows:
 - i. Excavate all planting pits to a diameter twice the size of container to be planted and 1 1/2 times the depth of container to be planted.

- ii. Contractor shall scarify the side of planting pits if an auger is used with shovel or digging bar.
- iii. Plant material shall be placed in planting pit in a manner as not to disrupt the root ball and the crown shall be set aligned flush to grade.
- iv. Provide 21 gram fertilizer tablets per detail.
- v. Backfill all plant material with approved backfill mix.
- vi. Contractor shall provide 5 gram fertilizer tablets to all rooted cuttings.

7. Percolation Test

- a. Contractor shall flood planting pits with water to test water penetration through the soil, if no penetration occurs the contractor shall auger 6 inches in diameter and 36 inches long and backfill with pea gravel, repeat water test and if water still does not penetrate the contractor shall notify the Owner's representative prior to planting.

8. Sodded Turf:

- a. All sodded areas shall be semi dwarf fescue unless otherwise noted.
- b. Contractor shall evenly rake all sodded areas to level and remove all rocks 3/4 inch in diameter and larger.
- c. Contractor shall spread 16-20-0 commercial fertilizer to all sodded areas.
- d. Contractor shall lay sod immediately upon arrival.
- e. Sod must be laid along a straight line staggering each row like laying bricks and must be butted tightly together preventing any air pockets. Do not overlap edges.
- f. Sod shall be cut with a sharp knife and never pulled apart.
- g. Sod shall be rolled immediately after sod is installed.
- h. Sod must be watered thoroughly to a depth of 12 inches.
- i. Contractor shall monitor watering to prevent browning and fungus.
- j. Contractor shall take every measure possible to protect sod by providing temporary fencing if necessary at no additional cost.

9. Turf Hydroseeding:

- a. Hydroseed seed mix shall be as indicated on the drawings.
- b. Contractor shall evenly rake all sodded areas to level and remove all rocks 3/4 inch in diameter and larger.
- c. Hydromix slurry shall be as follows:
 - i. Seed as specified
 - ii. Fiber 2,000 lbs. per acre
 - iii. M-Binder 100 lbs. acre
 - iv. Water 3,000 gal per acre or as required
 - v. Fertilizer/Soil Conditioner 1,100 lbs per acre
- d. Contractor shall monitor watering to prevent browning and fungus.
- e. Contractor shall take every measure possible to protect sod by providing temporary fencing if necessary at no additional cost.
- f. Hydromulch slurry shall be applied under high pressure evenly and provide a uniform coat an all areas specified.
- g. Overspray shall be removed immediately from sidewalks, walls or any structures.
- h. Contractor shall provide 98 percent germination to all hydroseeded areas prior to turn over.

10. Root Barriers:

- a. Root barrier shall be "Deep Root" control barrier panels # UB 24-2 or approved equal. No cylinder root barriers shall be approved.
- b. Root barriers shall be install for all trees planted within 5 feet of any hardscaping.
- c. Contractor shall install root barriers per detail.

11. Jute Netting:

- a. Jute netting shall be uniform plain weave, flame-retardant mesh. Geojute smolder resistant or approved equal. The mesh shall be green in color.
- b. Jute shall be 48 inches wide with a weight of .97 pounds per linear yard.

12. Grades:

- a. Prior to commencing any work the contractor shall carefully check all grades and verify that after all irrigation work and soil preparation

completed, all grades will be per specified depth as per the landscape contractor's scope of work with a +- 1/10.

13. Guarantee:

- a. All trees 15 gallon and larger the contractor shall guaranteed for a period of one year.
- b. All trees smaller than 15 gallon and all other plant material shall be guaranteed for a period of 90 days.
- c. All plant material which is dead or dying or as directed by the engineer within the guarantee period shall be replaced at the cost of the contractor with 7 days of written notice.
- d. All replacement plant material shall be exact as specified in species and size. No substitutions shall be allowed unless written approval from the engineer is obtained.

PART 4-PLANTING SPECIFICATIONS: MAINTENANCE

1. Maintenance Duration:

- a. Contractor shall maintain entire project within the contractor's scope of work until final approval for all work has been obtained to start the 90 calendar day maintenance at the contractor's expense.
- b. Contractor shall maintain all landscaped areas for a period of 90 calendar days unless otherwise noted.

2. Turf Maintenance:

- a. Contractor shall mow weekly or more if needed all turf areas to a height between 3/4 inch and 2 1/2 inch depending on variety of turf.
- b. Contractor shall edge all turf areas biweekly or more if needed.
- c. All clippings must be removed from sidewalks or adjacent areas.
- d. Contractor shall remove all excess clipping from turf areas.
- e. Contractor shall monitor watering to all turf areas and provide sufficient moisture levels to all turf area.

3. Tree and Shrub Maintenance:

- a. Contractor shall remove any dead growth on all trees and shrubs as needed.
- b. No stripping of lower branches from any tree or shrub unless directed by the engineer.

- c. Trees and shrubs shall be pruned as directed by the engineer.
- d. No topping of any tree is allowed unless directed by the engineer.
- e. Contractor shall remove tree stakes when stakes are no longer needed.

4. Weed Control:

- a. All tree and shrub basins and all areas must be weed free.
- b. Contractor shall apply pre-emergent herbicide where possible to prevent weeds as directed by a licensed pest control consultant.
- c. Contractor shall remove all weeds from site manually or chemically.

5. Rodent Control:

- a. Contractor shall be responsible for maintaining a rodent free project.
- b. All measures to eradicate rodents must be as directed by a licensed pest control consultant.
- c. Contractor shall repair/replace all damaged caused by rodents under this section.

6. Fertilization:

- a. Contractor shall fertilize turf, slope and planter areas every 30 calendar days with approved fertilizer at the manufacture's recommended application rate.
- b. Approved fertilizers are 15-15-15, 16-6-8 and 21-7-14.

7. Maintenance General:

- a. Edge groundcover as needed to maintain no growth over sidewalks, around tree and shrub basins or up walls or fences.
- b. Remove all trash weekly
- c. Test complete irrigation system biweekly.

8. Clean-Up:

- a. Clean up shall take place on a daily basis, after each portion of work has been completed and as directed by the Owner's representative. The contractor shall legally remove from site any trash or material from his scope of work.

9. Final Approval:

- a. All landscaped shall be inspected in it's entirety by the Owner's representative upon completion of 90 calendar day maintenance and have project turn over approved in writing.
- b. Contractor shall provide all charts, record drawings, turn over items etc. prior to final turn over.

- END OF SECTION -



**Standard Specifications
IRRIGATION SYSTEM**

CONTENTS

PART 1- Irrigation GENERAL1-6
PART 2-Irrigation Specifications MATERIAL6-18

IRRIGATION SYSTEMS

PART 1-IRRIGATION SPECIFICATIONS:

GENERAL

1. General Requirements:

- a. Permits: Contractor shall obtain and pay for any permits required.

2. Scope Of Work:

- a. The intent of the drawings and specifications is to indicate the processes required for the installation of a complete operating irrigation system without additional cost in labor and material to the Owner.
- b. The work consists of furnishing all tools, equipment, material, labor and any processes required to provide a complete operating irrigation system as specified in the drawings and specifications.
- c. Drawings are diagrammatic and must be field verified. Contractor to notify Engineer immediately of any discrepancies prior to starting work.
- d. Due to the scale of the drawings it is not possible to show all offsets, assemblies, fittings, etc. for a complete irrigation system.
- e. Under this section the contractor shall provide all necessary assemblies, fittings, etc. to provide a complete fully automatic irrigation system as listed in drawings and specifications with no additional cost to the owner.
- f. Any extra work performed shall be approved in writing by the Owner or Owner's representative prior to the start of such work.
- g. Any unapproved work may be at the contractor's expense.
- h. If reclaimed water is used, contractor shall provide all necessary reclaimed water signage and equipment. The entire irrigation system must be in accordance to the local reclaimed water specifications and as listed in drawings.

3. Record Drawings:

- a. Record accurately on one set of black and white prints denoting variation in work from original drawings.
- b. Dimension from two permanent points of reference (sidewalks, pavement, curbs, street lights, buildings) Record on as-builts daily or as work is performed. All drafting must be clearly legible and dimensions shall be no smaller than 1/4" in size
- c. Show dimensions from the following locations and depths:
 - i. Point of connection (P.O.C.).

- ii. Backflow prevention assembly, master valve and flow sensor.
 - iii. Routing of irrigation pressure mainlines and all directional changes.
 - iv. Ball and butterfly isolation valves.
 - v. Irrigation control valves.
 - vi. Automatic controller. rain sensors and electrical conduits.
 - vii. Sleeves and pull boxes.
 - viii. Other related equipment (as directed by the Engineer).
- c. Upon completion and approval of record drawing prints, transfer all information to reproducible mylars and provide two additional blue-line copies.
 - d. Maintain as-built drawings on site at all times. These drawings are subject to inspection at any time.
 - e. Make changes to reproducible drawings in ink (no ball-point pen). Erase or use eradicating fluid when revising drawings. Make changes in a manner equal to the original drawings.
 - f. Contractor must submit as-built drawings (sepia mylars and two sets of blue-lines) to the Engineer inspecting the site seven days prior to the start of the maintenance period for approval.

4. Controller Charts:

- a. As-built drawings shall be approved in writing prior to preparing charts.
- b. Provide two controller charts for each controller supplied, showing the area covered by the automatic controller.
- c. The chart shall be a reduced reproduction of the as-built system. If the controller sequence is not legible when reduced, enlarge it to a size that will be legible when reduced.
- d. Charts shall be blackline print with a different transparent color used to show area of coverage for each station.
- e. When completed and approved, laminate the charts with plastic 10 mil thick minimum.
- f. Charts shall be completed and approved prior to final inspection of the irrigation system.
- g. Controller access. The Engineer reserves the right to have complete access to

the controller clocks for monitoring and controlling system failures. The contractor shall provide the Engineer with two sets of all keys necessary for access to the controller clocks within the designated area. The keys will then become the property of the Owner.

5. Operation and Maintenance Manuals:

- a. Prepare and deliver to the Engineer, prior to the start of maintenance, all required and necessary descriptive material in complete detail and sufficient quantity properly prepared in four individually bound copies. Describe the material installed in sufficient detail to permit qualified operating personnel to understand, operate and maintain all equipment. Each manual shall include the following:
 - i. Index sheet stating contractor's address and telephone number.
 - ii. Duration of guarantee period with guarantee forms.
 - iii. List of equipment with names and addresses of manufacture's local representatives.
 - iv. Complete operating and maintenance instructions on all major equipment.
- b. In addition to the maintenance manuals, provide the maintenance personnel with the instructions for major equipment and show written evidence to the Engineer at the conclusion of the work that this service has been completed.

6. Spare Parts and Equipment:

- a. Prior to the start of maintenance prepare and deliver to the Engineer, all required spare parts, tools and equipment. Spare parts, tools and equipment shall include but not limited to the following:
 - i. Two quick coupler keys with 3/4 inch bronze hose bib with hand wheel.
 - ii. Two quick coupler lid keys
 - iii. One valve box cover wrench or key
 - iv. Two wrenches and shrew drivers for adjustment and disassembly for each type of sprinkler head used in the irrigation system
 - v. One 5 foot tee wrench for operating isolation valves specified
 - vi. Six extra sprinkler heads of each type and size used in the irrigation system.
 - vii. Remote radio device for irrigation controller(s) if specified

7. Guarantee:

- a. Provide written guarantee in form approved that all work with defects in

workmanship and materials will be repaired or replaced at no cost to the Owner for a period of one year from the date of acceptance by the Owner's representative.

- b. This form shall be transferred onto the contractor's letterhead and must contain the following :

Name of Project

We hereby guarantee that the irrigation system we have furnished and installed for **Name of Project** is free from defects in materials and workmanship, and the work has been completed in accordance with the drawings and specifications. Ordinary wear and tear and unusual abuse or neglect expected. We agree to repair or replace any defects in material or workmanship which may develop during the period of one (1) year from the date of acceptance and also to repair or replace any damage resulting from the repairing or replacing of such defects at no additional cost to the Owner. We shall make such repairs or replacements within a reasonable time after receipt of such written notice. In the event of our failure to make such repairs or replacements within a reasonable time after receipt of such written notice from the Owner , we authorize the Owner to proceed to have said repairs or replacements made at our expense and we will pay for the cost and charges therefore upon demand.

Project Name: _____

Owner: _____

Landscape Architect: _____

Location: _____

Signed: _____ Title: _____

Address: _____

Telephone : (____)_____

Date of Signature: _____

8. Inspections:

- a. Site inspections and notification time.

- i. Pre-construction conference 7 days
- ii. Pressure line installation and testing 48 hours
- iii. Controller installation 48 hours
- iv. Lateral line and sprinkler installation 48 hours
- v. Coverage test 48 hours
- vi. Final Inspection 7 days

- b. No field inspections will commence unless record drawings are current and

available for observation upon request by the Owner's representative.

9. Irrigation System Testing:

- a. Owner's representative must be notified 48 hours prior to any irrigation testing or inspections.
- b. Contractor shall perform a pressure test to all pressure lines in the presence of the Owner's representative.
- c. All pressure line must be tested under hydrostatic pressure of 150 pounds per square inch (PSI) and be proven water tight.
- d. Pressure lines must maintain pressure for as period of 2 hours. If pressure drop occurs, contractor shall replace joints and repeat test until no pressure drop is achieved.

10. Pressure Line Observation:

- a. Prior to any backfilling of any trench(s) contractor shall call for field observation for verification of material, depths, clearances and warning tape by the Owner's representative.
- b. Any trenching covered that was not inspected or approved shall be made visible for observation at the cost of the Contractor.

11. Controller Testing:

- a. Prior to final acceptance contractor shall provide certification from manufacture stating that controller specified on drawings has been installed per manufacturer's specifications.
- b. Contractor shall test in the presence of the Owner's representative that all control wires and extra control wires are functioning properly.
- c. Contractor shall provide sufficient manpower and/or radio device to complete such testing in a timely manner.

12. Lateral Line Testing:

- a. Prior to any backfilling of any trench(s) contractor shall call for field observation for verification of material, depths and clearances by the Owner's representative.
- b. All sprinklers and assemblies shall be made visible for observation for verification that all material has been installed per plans and specifications.
- c. Any trenching covered that was not inspected or approved shall be made visible for observation at the cost of the Contractor.

13. Coverage Test:

- a. Contractor shall perform a coverage test in the presence of the Owner's representative. All irrigation sprinkler systems must providing 100% head to head

coverage. Any areas not receiving head to head coverage shall be corrected and retested per the Owner's representative.

- b. Contractor shall provide sufficient manpower and/or radio device to complete such testing in a timely manner.
- c. All heads must be adjusted to prevent overspray to buildings, walks, streets etc. (see adjusting the system section).
- d. No planting or hydroseeding shall take place until coverage test as been approved in writing by the Owner's representative. Tree planting may commence upon approval from Owner's representative.

14. Final Irrigation Inspection:

- a. All irrigation systems shall be tested in the presence of the Owner's representative and by under complete automatic operation and proven to be leak free irrigating designated areas per plans and specification with least amount of overspray as possible.
- b. Contractor shall provide as-built record drawings and controller charts at final irrigation inspection for approval prior to mylar transfer and laminating.
- c. All irrigation turn over items shall be turned in to the Owner's representative prior to the start of maintenance.

PART 2-IRRIGATION SPECIFICATIONS: MATERIALS

1. Backflow Prevention Devices:

- a. Backflow prevention units shall be approved by the Foundation for Cross-Connection Control and Hydraulic Research.
- b. Backflow assemblies shall be installed using brass ells, unions and nipples.
- c. Type: Febco 825Y, Wilkens 975XL ,Watts 909 or approved equal.
- d. Backflow device enclosure shall be constructed of stainless steel #9 expanded metal with a angle iron frame. Enclosure shall have a hinge on one end that allows for removal of the enclosure for backflow service. Enclosure shall be bolted to a concrete pad using galvanized steel hardware.

Manufactures: LeMuer, Strong Box, All Spec or approved equal.

2. Pressure Reducing Valves:

- a. Pressure reducing valves shall be of bronze and stainless steel construction and be adjusted from 25 P.S.I. to 125 P.S.I.

Manufactures: Wilkens 500HLR or approved equal.

3. Wye Strainers:

- a. Wye strainer shall be bronze construction with a stainless steel screen element. Wye strainer shall have a standard filtration size of 80 mesh.

Manufactures: Wilkens 100YSBR or approved equal.

4. Shut off Valves:

- a. Ball Valve:

- i. Shut off valves 2 inch and smaller shall be ball valves.
- ii. Ball valves shall have a one piece body constructed of 600 lb. WOG Bronze material conforming with ASTM B-584 alloy 844. Ball valve shall have a vented ball with a blowout proof system. Ball valves shall have a working pressure of not less than 150 P.S.I. and shall conform to AWWA standards.

Manufactures: Nibco 560, Wilkens 850 or approved equal.

- b. Butterfly Valves:

- i. Shut off valves 2 1/2 inch and larger shall be butterfly valves.
- ii. Butterfly valves shall have a one piece body constructed of cast iron and stainless steel stem. Butterfly valves shall be equipped with Vanstone large adapters and a 2 inch square operating nut. Butterfly valves shall have a working pressure of not less than 150 P.S.I. and shall conform to AWWA standards. Butterfly valves shall have a ductile iron porcelain enamel coated disc.

Manufactures: Nibco, Matco or approved equal.

5. Quick Coupler Valves:

- a. Quick coupler valves shall have a body constructed of red brass with a wall thickness guaranteed to withstand normal working pressure of 150 P.S.I. without leakage with female threads (pening at base). Quick coupler valve shall have a hinge cover constructed of red brass with a leather like vinyl cover bonded to it on such a manner that it becomes permanent type of cover. Quick couplers used with potable water shall have vinyl covers yellow in color. Quick coupler valves used for reclaimed water shall have vinyl covers purple in color with the appropriate reclaimed water warnings in English and Spanish as well as the international "Do Not Drink" symbol.

Manufactures: Potable Water: Rainbird 44LRC or approved equal
Reclaimed Water: Rainbird 44NP or approved equal

6. Remote Control Valves:

- a. The remote control valve shall be normally closed 24 VAC solenoid actuated globe pattern, spring loaded diaphragm type. The valve shall be pressure rated up to 200 P.S.I. at 150 degrees F.
- b. The valve shall have a 600 pound test fabric reinforced rubber diaphragm assembly with self-cleaning stainless steel screen.
- c. Remote control valve body and bonnet shall be brass and the valve shall have a stainless steel control/ shut-off stem and manual operator.

Manufactures: Rainbird PESB series or approved equal.

7. Master Control Valves:

- a. The master control valve shall be a switchable normally closed or open 24 VAC solenoid actuated globe pattern, spring loaded diaphragm type. The valve shall have up to 200 P.S.I. at 150 degrees F. pressure rating.
- b. The body bonnet shall be brass or cast iron and the valve shall have a stainless steel control shut-off stem and manual operator.
- c. The valve shall have a 600 pound test fabric reinforced rubber diaphragm assembly with self-cleaning stainless steel screen.

Manufactures: Griswold 2000 series, Rainmaster EV-MV or approved equal.

8. Flow Meter:

- a. Flow meter shall be constructed of a schedule 80 tee with an solid state o-ring sealed epoxy fused sensor housing and nylon impeller.
- b. Flow meter must be installed and wired per manufacturer's specifications.

Manufactures: Data Industrial, Calsence or approved equal.

9. Rain Sensor:

- a. Rain sensor shall be a heavy duty plastic container with epoxy sealed electronics installed within a 1/8 inch thick steel enclosure. Mount sensor on controller enclosure or building eave per manufacturer's specifications. Sensor shall be wired per manufacturer's specification.

Manufactures: WCS Rainguard, Rainbird Raincheck or approved equal.

10. Basket Strainer:

- a. Basket strainer shall be manufactured with a bronze body with a 80 mesh filtration element with a stainless steel basket.

Manufactures: Hayward or approved equal.

11. Booster Pump:

- a. Booster pump shall be as manufactured by Barrett Engineered Pumps, San Diego, California (619) 232-7867. Pump shall be determined by the engineer.

12. Automatic Controller:

- a. The controller shall operate on a minimum of 120 volts A.C. power input and shall be capable of operating up to four 5.5 VAC 24 volt A.C. remote control valves at once. The controller shall have a reset circuit breaker to protect the controller from overloading.
- b. The controller shall have independent programmable stations. The controller programming schedule shall be capable of allowing four automatic start times per day on four separate programs. Station timing shall be variable from 1 to 99 minutes. The controller must have a water budgeting function to allow increasing or decreasing of watering times for all stations at once.
- c. The controller shall have a master valve/remote pump start circuit for use with a master valve to pressurize the system when the programmed cycle starts to activate a remote pump start relay to run the pump during the programmed cycle.
- d. The controller shall have manual watering capabilities for single station operation at any time with out changing programmed times.
- e. The controller shall have a factory installed backup program for standby operation and a backup battery to maintain the programs during power loss.
- f. Install one extra 1 1/2" inch conduit to controller for future use.

Manufactures: Calsence ET1 or approved equal.

13. Controller Enclosure:

- a. All controllers installed outside must be mounted inside a stainless steel enclosure with lockable hinged doors.
- b. The enclosure shall have one full time 120 VAC GFCI type circuit with on/off switch and pigtail connection for remote control use.

Manufactures: Lemuer, Strong Box, All Spec or approved equal.

14. Control Wiring:

- a. All control wiring for connections between remote control valves and controller shall be direct burial AWG-F wire installed in accordance with manufacture's specifications.
- b. All splices shall be sealed with water-proof connectors and water-proof sealant.

Manufactures: Rainbird Pen Tite, Snap Tite, Dri-Splice or approved equal.

- c. Wiring shall be buried adjacent to mainline wherever possible and for more than one wire they shall be bundled at every ten feet using black electrical tape.
- d. Expansion curl shall be provided within three feet of each connection and at all changes in direction. Provide a two foot expansion loop for every 100 feet of run.
- e. Wire size shall not be less than #14 gauge.
- f. Control wires shall be black in color. If additional controllers are installed provide different color common wires for each controller.
- g. Common wire shall be white in color. If additional controllers are installed provide white wire with colored stripe. Stripe to be same color as control wire color.
- h. Contractor shall provide one extra wire for every five valves and two extra wires shall be provided for every valve in any isolated area and the extra wires shall extend past the last valve in a group. Extra wires shall be orange in color and looped in every valve box and made accessible for future use if needed.
- i. No wire splices shall be permitted unless run is longer than 2500 feet or approved by Owner's representative.

15. Valve Boxes:

- a. Rectangular valve boxes shall be 9 1/2 inch wide by 16 inch long and 11 inch high. Round valve boxes shall be 10 inch diameter and 10 1/4 inch. All valve boxes shall be constructed of rigid polyolefin.
- b. Valve boxes shall have locking covers secure with a 3/8 inch stainless steel bolt and washer.
- c. Rectangle valve boxes shall be used for control valves, master control valves, pressure regulators, flow sensors, wye strainers, basket strainers ball valves, butterfly valves and pull boxes.
- d. Round valve boxes shall be used for quick coupler valves.
- e. All valve boxes to be green in color unless otherwise specified for use of reclaimed water. All valve boxes for reclaimed water shall be purple in color and bare the reclaimed water warnings as well as the international "Do Not Drink" symbol.
- f. Heat brand all box lids with the appropriate two inch high identification letters and/or numbers.
- g. All valve boxes shall receive landscape fabric. Landscape fabric shall be constructed of 5.0 oz. weight proven polypropylene weed barrier with a burst strength of 225 P.S.I. and capable of 12 gallons per minute of water

flow and a puncture strength of 60 lbs. Dewitt Pro, Mirfy or approved equal.

- h. All valve boxes shall receive 2 cubic feet of 3/4 inch gravel per plan.

Manufactures: Carson, Brooks, NDS or approved equal.

16. General Piping:

- a. Pressure line from point of connection to backflow prevention device shall be brass or Type K copper
- b. Pressure lines 2" and smaller after backflow prevention device shall be Schedule 40 solvent weld PVC
- c. Pressure lines 2 1/2 inch to 3 inch after backflow prevention device shall be Class 315 solvent-weld P.V.C.
- d. Pressure lines 1 1/2 inch and smaller after backflow prevention device shall be Schedule 40 solvent-weld P.V.C.
- e. Pressure lines 4 inch and larger after backflow device shall be Class 200 bell and gasket P.V.C.
- f. Lateral lines 1 1/2 inch and smaller shall be Schedule 40 solvent-weld P.V.C.
- g. Lateral lines 2 inch and larger shall be Class 315 solvent-weld P.V.C.
- h. All pipe and fittings shall bear the markings of the Manufacturer's name, nominal pipe size, pressure rating P.S.I., NSF, schedule or class and date of extrusion.

17. Plastic Pipe:

- a. Solvent weld pipe shall conform to ASTM D 1784 or D 2241 to meet the requirements of cell classification 12454B for pipe. Pipe shall be extruded of an improved P.V.C. virgin pipe compound high impact strength. Compound shall have a hydrostatic design stress rating of 2,000 P.S.I.

Manufactures: Pacific Plastics or approved equal.

- b. Rubber gasket P.V.C. pipe shall conform to ASTM D-1784 Type I, Grade I 2,000 P.S.I. design stress. All pipe shall conform to commercial standards CS-256-64 and NSF testing laboratories. Rubber gaskets shall conform to ASTM 1869.

Manufacturers: Pacific Plastics or approved equal.

- c. Reclaimed water pipe shall conform to ASTM D1784 or D 2241 to meet the requirements of cell classification 12454B for pipe. Pipe shall be extruded of an approved P.V.C. virgin pipe compound high strength. Compound shall have a hydrostatic design street rating of 2,000 P.S.I.

Reclaimed water pipe shall be purple in color and bare the words "CAUTION - RECLAIMED WATER" printed in black letters on two sides of all pipes.

Manufacturers: Pacific Plastics, Alertline or approved equal.

- d. Ultra Violet Resistant (U.V.R.) pipe shall conform to ASTM D 1784 or D 2241 to meet the requirements of cell classification 12454B for pipe. Pipe shall be extruded of an approved P.V.C. virgin pipe compound high strength. Compound shall have a hydrostatic design street rating of 2,000 P.S.I.. U.V.R. pipe shall be manufactured using material proven to resist corrosion by ultra-violet radiation. Pipe shall be brown in color.

Manufacturers: Pacific Plastics, Browline, Sun Stop or approved equal.

18. Fittings:

- a. All pressure line fittings 3 inch and smaller shall be Schedule 80 solvent weld P.V.C.. Fabricated pipe shall be from an NSF approved Type I, Grade I, P.V.C. compound conforming to ASTM D1784

Manufacturers: Dura, Lasco or approved equal.

- b. All pressure line fittings 4 inch and larger shall be iron ductile deep bell type constructed of grade 65-45-12 and shall be in accordance with ASTM A536. Rubber for gaskets in fittings shall be in accordance with ASTM-477. All iron ductile fittings shall have stainless steel exterior lugs to secure a joint restraint system.

Manufacturers: Leemco or approved equal.

- c. All lateral line fittings downstream control valve shall be Schedule 40 solvent weld P.V.C.. Fabricated pipe shall be from an NSF approved Type I, Grade I, P.V.C. compound to ATTM D1784

Manufacturers: Dura, Lasco or approved equal.

- d. Provide primer and solvent cement for PVC solvent weld pipe and fittings of specified type by manufactures recommendations.

Manufacturer: Weld-on or approved equal.

- e. All fittings shall have the manufacture's name, trademark and size applicable NSF or IPS approval.
- f. All threaded fittings shall have 3/4 inch teflon tape.

19. Brass Pipe and Fittings

- a. Brass pipe shall be in accordance with American National Standard Institute and be 85 percent Schedule 40 red brass.

- b. Brass fittings shall be threaded 125 pound class.

20. Galvanized Steel Pipe and Fittings:

- a. Galvanized steel pipe shall be Schedule 40 hot dipped galvanized.
- b. Galvanized fittings shall be Schedule 40 hot dipped galvanized.

21. Irrigation Heads (General)

- a. All irrigation heads shall be the size, type, and provide the same rate of precipitation with the same radius of spray, pressure and discharge in G.P.M. as listed on drawings
- b. All spray head sprinklers shall have stainless steel screw adjustment for radius of spray.
- c. Riser and swing joint assemblies shall be as indicated on drawings.
- d. All irrigation heads shall have an factory installed check valve or have an after market check valve installed.
- e. All other requirements for non-pressure lateral line pipe to be as specified in fitting specification section.
- f. In no case shall the irrigation head spacing exceed the maximum manufacturer's recommendation.
- g. Irrigation heads along walks, curbs, paving, etc. shall be positioned 1 inch above finish grade. Irrigation in turf areas shall be positioned 2 inches above finish grade.
- h. All sprinkler heads shall be set perpendicular to finish grades.

22. Bubblers:

- a. Bubblers shall be constructed of heavy duty plastic and be pressure compensation full circle. The bubbler shall have a screen to protect it from clogging.
- b. Bubblers shall be adjustable from .25 - 1.0 GPM and operate between 20-90 PSI.

Manufacturer: Rainbird 1400 Series or approved equal.

23. Sprinkler Heads

- a. The sprinkler body, nozzle, stem and screen shall be molded out of heavy duty plastic.
- b. Pop-up height shall be as listed in drawings and in no case shorter than 4 inches.

- c. The sprinkler shall have an adjustment screw used for regulating flow and radius with matched precipitation rate (MPR) nozzle.
- d. The sprinkler shall have a removable screen to protect it from clogging.
- e. The sprinkler shall have a stainless steel spring for proper pop-down.
- f. The sprinkler shall be equipped with a factory installed check valve (seal-a-matic {SAM}) identified on the cap and capable of holding water up to 10 feet of elevation change.
- g. The sprinkler shall be equipped with a factory installed pressure regulating device constructed of stainless steel and heavy duty plastic capable of maintaining a pressure of 35-70 P.S.I. to 30 P.S.I. for operation of the sprinkler.

Manufacturers: Rainbird 1800-SAM-PRS or approved equal.

24. Rotor Heads (Medium Range):

- a. All pop-up rotors shall have a rubber cover and be constructed of heavy duty plastic except for wiper seal, bearing spring and bearing washers. All rotors to have a reinforced rib design with flange incasement.
- b. Pop-up height shall be as listed in drawings and in no case be shorted than 3 1/2 inches.
- c. The rotor shall have a diffuser pin for regulating flow and radius.
- d. The rotor shall have a screen to protect it from clogging and have a minimum inlet of 3/4 inch.
- e. The rotor shall be capable of covering 16-55 feet radius at 20-60 PSI with a rate of .5 - 9.2 GPM. and be adjustable from 1-360 degrees.

Manufacturers: Hunter PGP, Hunter I-20, Rainbird T-Bird or approved equal.

25. Rotor Heads (Large Range):

- a. All pop-up rotors shall have a rubber cover and be constructed of heavy duty plastic except for wiper seal, bearing spring and bearing washers. The riser shall be constructed of plastic encased in a stainless steel sleeve. All rotors to have a reinforced rib design with flange encasement.
- b. Pop-up height shall be as listed in drawings and in no case be shorted than 3 1/2 inches.
- c. The rotor shall have a diffuser pin for regulating flow and radius.
- d. The rotor shall have a screen to protect it from clogging and have a minimum inlet of 1 inch.
- e. The rotor shall be capable of covering 16-55 feet radius at 40-74 PSI with

a rate of 3.8 - 27.5 GPM. and be adjustable from 1-360 degrees.

Manufacturers: Rainbird Falcon, Hunter I-25, Hunter I-40 or approved equal.

26. Trenching and Backfilling:

- a. No trenches are to be backfilled until approval from Owner's representative has been acquired.
- b. Excavate trenches straight and support pipe continuously on the bottom of trench per layout indicated on drawings.
- c. All lines shall have a minimum clearance of 4 inches from each other and 24 inches from any other lines from other trades.
- d. Provide the minimum covers as listed below:
 - i. Pressure lines 4 inch and larger 30 inches
 - ii. Pressure lines 3 inch and larger: 24 inches
 - iii. Pressure lines 2 1/2 inches and smaller: 24 inches
 - iv. Lateral lines 18 inches
 - v. Control wiring 24 inches
- e. Fine granular soil not larger than 1/2 inch shall be for initial backfill and compacted to a density equal to undisturbed soil. Clean backfill soil not greater than 1 inch for remaining backfill.
- f. No flooding shall be performed to compact trenches unless approved by the Owner's representative.
- g. Sand backfill to a minimum of 3 inches shall be applied to all piping under paved areas.
- h. If any settlements occur and irrigation adjustments are required the contractor shall make these adjustments with no additional cost to the Owner.
- i. Contractor shall install concrete thrust blocks for all pressure lines 2 inch and larger. Thrust blocks shall be a minimum size of one cubic foot. For bell and gasket pipe a joint restraint system shall be used instead of thrust blocks per manufacture's specifications.

27. Flushing the System:

- a. Open control valve after all piping and required assemblies have been completed to flush out the system.
- b. Irrigation heads are to be installed after completion of flushing the system

satisfactory to the Owner's representative.

28. Adjusting the System:

- a. The contractor shall flush and adjust all irrigation heads, control valves, pressure regulators, etc. for optimum performance.
- b. All heads must be adjusted to prevent overspray to buildings, walks, streets etc.

29. Sleeving:

- a. All sleeving shall be 2 times the diameter of the pipe used. Sleeving for control wires shall be 2 inches in diameter minimum.
- b. All sleeving shall have minimum a cover of 24 inches under paving
- c. All trenches for sleeving must be compacted to 95% compaction using manual or mechanical taping device.
- d. Contractor shall cap and pressure test all pressure lines under paving prior to backfilling and paving.
- e. Contractor shall be responsible for the installation of all sleeves required for the irrigation system not listed in the drawings.

30. Layout:

- a. Contractor shall layout irrigation mainline, valves, sprinklers etc. for approval from the Owner's representative.

31. Additional Miscellaneous Items:

- a. All pipe above grade are to be stabilized with j-hooks at every 10 feet. J-hooks shall be #4 x 18 inch rebar painted with black epoxy paint prior to installation.
- b. All assemblies requiring rebar stabilizing rods per plan and details shall be with #4 x 30 inch rebar and supported by vandal proof clamps constructed of stainless steel installed with a tool specifically designed for the process.
- c. Contractor shall install metallic warning tape over all pressure supply line with a cover of 12 inches from grade. Warning tape for potable water shall be blue in color and the words, "CAUTION WATER LINE" permanently attached to tape. Warning tape for reclaimed water shall be
- d. Lavender in color and the words, "CAUTION RECLAIMED WATER" permanently attached to tape. Warning tape shall be 3" wide minimum.
- e. Contractor shall provide identification tags with the number labeled for each valve attached the each valve. For potable water the tags shall be yellow in color with black lettering. For reclaimed water the tags shall be lavender in color with black lettering.

- f. All utilities, valve boxes, valves, sprinklers, quick couplers, etc. shall either have lavender caps or lavender colored parts as provided by the manufacturer for use a reclaimed water.
- 32. Water Supply:**
- a. The Irrigation system shall be connected to water supply as shown on drawings. Contractor shall notify Architect immediately of any discrepancies.
- b. The Contractor shall be responsible for any minor changes due to actual site conditions.
- 33. Electrical Supply:**
- a. Contractor to coordinate final location of controller with job site Superintendent and Owner's representative.
- b. Prior to installation of controller contractor to verify that all required electrical equipment is accessible for complete installation.
- c. Electrical connections and equipment must be as listed in controller installation section and per manufacturer's specifications.
- 34. Grades:**
- a. Prior to commencing any work the contractor shall carefully check all grades and verify that after all irrigation work and soil preparation completed, all grades will be per specified depth as per the landscape contractor's scope of work with a +- 1/10.
- 35. Maintenance:**
- a. Contractor shall have irrigation system under complete operation for a period of 7 days prior to and planting or hydroseeding.
- b. Contractor shall maintain entire irrigation system to an acceptable condition to the Owner's representative for the period of 90 days unless otherwise noted.
- 36. Clean-Up:**
- a. Clean up shall take place on a daily basis, after each portion of work has been completed and as directed by the Owner's representative. The contractor shall legally remove from site any trash or material from his scope of work.
- 37. Final Approval:**
- a. All irrigation shall be tested in it's entirety by the Owner's representative and approved in writing before commencement of planting and hydroseeding accept for trees as directed by the Owner's representative.

b. Contractor shall provide all charts, record drawings, turn over items etc. as listed in Irrigation (general) section prior to final approval.

- END OF SECTION -